

COATS®

Tread Scanner



Installation Instructions

READ these instructions before placing unit in service. KEEP these and other materials delivered with the unit in a binder near the machine for ease of reference by supervisors and operators.

HENNESSY
INDUSTRIES

1601 J. P. Hennessy Drive, La Vergne, TN USA 37086 615/641-7533 800/688-6359 www.coatsgarage.com
HENNESSY INDUSTRIES LLC Manufacturer of COATS®, AMMCO® and BADA® Automotive Service Equipment and Tools.

Manual Part No.: 85611869 01
Revision: 09/20

IMPORTANT SAFETY INSTRUCTIONS

READ ALL INSTRUCTIONS

1. Do not stare directly into light source of the unit.
2. Read and understand this manual before operating. Abuse and misuse will shorten the functional life.
3. Do not operate equipment with a damaged cord or if the equipment has been dropped or damaged – until it has been examined and repaired by a qualified serviceman.
4. Do not let cord hang over edge of table, bench, or counter or sharp metal object edges.
5. If an extension cord is necessary, a cord with a current rating equal to or more than that of the equipment should be used. Cords rated for less current than the equipment may overheat. Care should be taken to arrange the cord so that it will not be tripped over or pulled.
6. Keep guards and safety features in place and in working order.
7. Keep work area clean and well lighted. Clutter and/or dark areas invite accidents.
8. Avoid dangerous environments. Do not use power tools or electrical equipment in damp or wet locations, or expose them to rain.
9. Use only manufacturer's recommended accessories. Improper accessories may result in personal injury or property damage.
10. Repair or replace any part that is damaged or worn. Do not operate damaged equipment until it has been examined and serviced by an authorized service technician only. This unit contain no user serviceable parts.
11. Do not allow untrained persons to operate machinery.
12. To reduce the risk of fire, do not operate equipment in the vicinity of open containers or flammable liquids (gasoline).
13. Use equipment only as described in this manual. Do not modify the unit or remove protective covers or housings.
14. Use only manufacturer's recommended attachments and accessories.

SAVE THESE INSTRUCTIONS



Table of Contents

Important Safety Instructions	ii
Owner's Responsibility.....	iv
Operator Protective Equipment.....	iv
Definitions of Hazard Levels.....	iv
Symbols Used	iv
Installation Instructions	1
Information on Pre-installation Location	1
Assembly Case for Floor Level Installation	2
Evenness of The Measuring Unit	2
Network Environment	2
Special Accessories.....	2
Electrics	2
Measurement Bay	3
Set-up Tread Scanner and Camera	4
Installation Tread Scanner on Floor.....	5
Size	6
Foundation Layout	7
Floor Levelness and Central Unit	9
Checklist	10

Owner's Responsibility

To maintain machine and user safety, the responsibility of the owner is to read and follow these instructions:

- Follow all installation instructions.
- Make sure installation conforms to all applicable Local, State, and Federal Codes, Rules, and Regulations; such as State and Federal OSHA Regulations and Electrical Codes.
- Carefully check the unit for correct initial function.
- Read and follow the safety instructions. Keep them readily available for machine operators.
- Make certain all operators are properly trained, know how to safely and correctly operate the unit, and are properly supervised.
- Allow unit operation only with all parts in place and operating safely.
- Carefully inspect the unit on a regular basis and perform all maintenance as required.
- Service and maintain the unit only with authorized or approved replacement parts.
- Keep all instructions permanently with the unit and all decals/labels/notices on the unit clean and visible.
- Do not override safety features.

Operator Protective Equipment

Personal protective equipment helps make tire servicing safer. However, equipment does not take the place of safe operating practices. Always wear durable work clothing during tire service activity. Loose fitting clothing should be avoided. Tight fitting leather gloves are recommended to protect operator's hands when handling worn tires and wheels. Sturdy leather work shoes with steel toes and oil resistant soles should be used by tire service personnel to help prevent injury in typical shop activities. Eye protection is essential during tire service activity. Safety glasses with side shields, goggles, or face shields are acceptable. Back belts provide support during lifting activities and are also helpful in providing operator protection. Consideration should also be given to the use of hearing protection if tire service activity is performed in an enclosed area, or if noise levels are high.

Eye Safety

Recommendation: Whenever possible do not look into the source of the beam. Use optional tinted glasses (OD1, optical density).

Definitions of Hazard Levels

Identify the hazard levels used in this manual with the following definitions and signal words:

DANGER

Watch for this symbol:



It Means: Immediate hazards, which will result in severe personal injury or death.

WARNING

Watch for this symbol:



It Means: Hazards or unsafe practices, which could result in severe personal injury or death.

CAUTION

Watch for this symbol:



It Means: Hazards or unsafe practices, which may result in minor personal injury or product or property damage.



Watch for this symbol! It means BE ALERT! Your safety, or the safety of others, is involved!

Symbols Used



Information: Practical hints and other useful information.



1. Multi-step operation: Instruction consisting of several steps.



One-step operation: Instruction consisting of one step.



Intermediate result: An instruction produces a visible intermediate result.



Final result: There is a visible final result on completion of the instruction.



Observe all hazard notices on products and ensure they remain legible.

Installation Instructions

Information on Pre-Installation Location General Test Conditions

- Only use the Tread Scanner indoors.
- Avoid direct and intense solar radiation on the glass plate.
- Remove dirt and moisture beneath Tread Scanner.
- The ground below the measuring unit must be suitable for installation with dowels and for taking the load of the central support (concrete or asphalt floors).



Correct alignment and fixed connection to the flooring are key to successful measurement. Smooth or tiled concrete floors are best suited. Asphalt floors are often uneven and have low bearing pressures. Special care is required when bolting with asphalt anchors (optional accessories).

- Troughs or sleepers (e.g. gullet) that influence the speed or vibration behavior of the vehicle are not permitted before or after Tread Scanner. Floor unevenness of max. 1 inch (25 mm) is permissible.
- Observe the following data on temperature and working environment:

Temperature and Working Environment

Function	Specification
Working temperature / Function range	-13 °F to + 113 °F (-25 °C to +45 °C)
Storage temperature	-13 °F to +140 °F (-25 °C to +60 °C)
Maximum humidity	95%
Maximum operating altitude	7,200 feet above sea level (2200 m ü.N. N.)
Minimum floor load-bearing capacity	4,350 PSI (30 N/ mm ²)

Avoiding Minimum Turning Curve

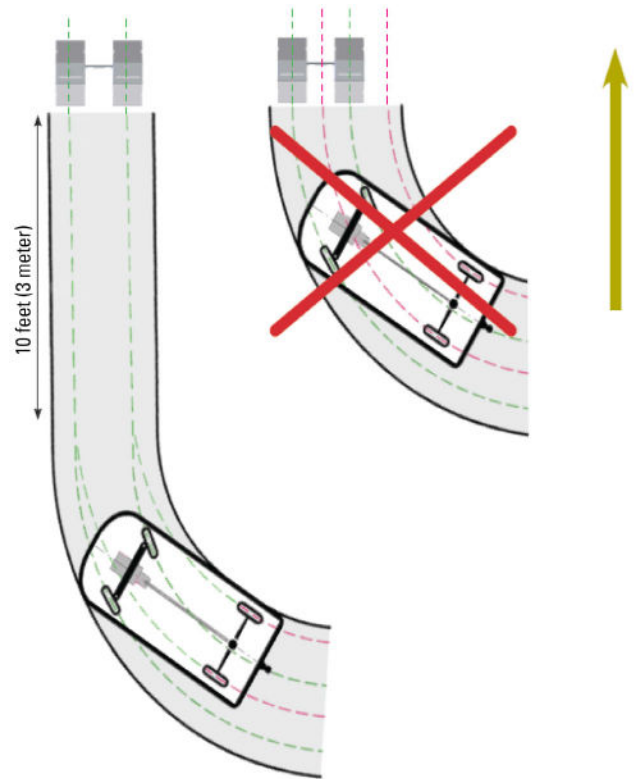

Fig. 1: Access Route, Avoid Minimum Turning Curve

- ☐ Access route of at least 10 feet (3 meters) must be ensured.

Assembly Case for Floor Level Installation

- ▣ An assembly case (not included in the scope of delivery, see “Special Accessories”) is required for the floor level installation of the Tread Scanner.
- ▣ The assembly case must be grouted when the baseplate is made (see “Foundation Layout”).
- ▣ If no Camera is installed, a center cover is required (not included in the scope of delivery, see “Special Accessories”).



Fig. 2: Edge Protection Frame

Evenness of The Measuring Unit

Observe the following permissible height differences when mounting the measuring unit on the floor:

Ground Evenness of Measuring Unit

Permissible Height Difference	Value
Transverse direction (left to right)	$\frac{3}{16}$ inch (5 mm)
Longitudinal direction (front to rear)	$\frac{1}{8}$ inch (3 mm)
Diagonal direction (front/rear to left/right)	$\frac{3}{16}$ inch (5 mm)

See also “Floor Levelness and Central Unit.”

Network Environment

- ▣ The customer must provide 2 static, (optionally 3) “IPv4 addresses” for Smart TV.

Designation	Standard IP Addresses
Factory setting of the modules	192.168.10.1
Master (static)	192.168.10.10
Satellite (static)	192.168.10.20
Camera	192.168.10.30
Customer PC	192.168.10.100
Smart TV	192.168.10.110

Special Accessories

Designation	Number of Items	Part Number
Shear connector assembly kit	10	1691201017
Assembly case for Tread Scanner floor-level	1	1691200028
Centre cover for Tread Scanner floor-level without Camera	1	1691202094

Electrics



The power supply of the electrical cabinet (power supply cable) must be connected by an electrician with the applicable local qualification.



The electrical power supply cable must be laid only up to the electrical cabinet.



Allow for a suitable place on the wall for the electrical cabinet.

Electrical Data

Function	Specification
Power Supply	110 V, 15 A 50-60 Hz 1-phase
System performance	200 W
Maximum distance of transfer points Voltage supply Network	<ul style="list-style-type: none"> • 33 feet (10 m) • 33 feet (10 m), optional 66 feet (20 m)
Degree of protection of diagnostic modules	IP65
Degree of protection switch, cable extensions, data cable, TV, etc.	n.a.
Dimensions electrical cabinet	15 1/4 x 9 1/4 x 6 inches (387 x 234 x 150.8 mm)

Measurement Bay

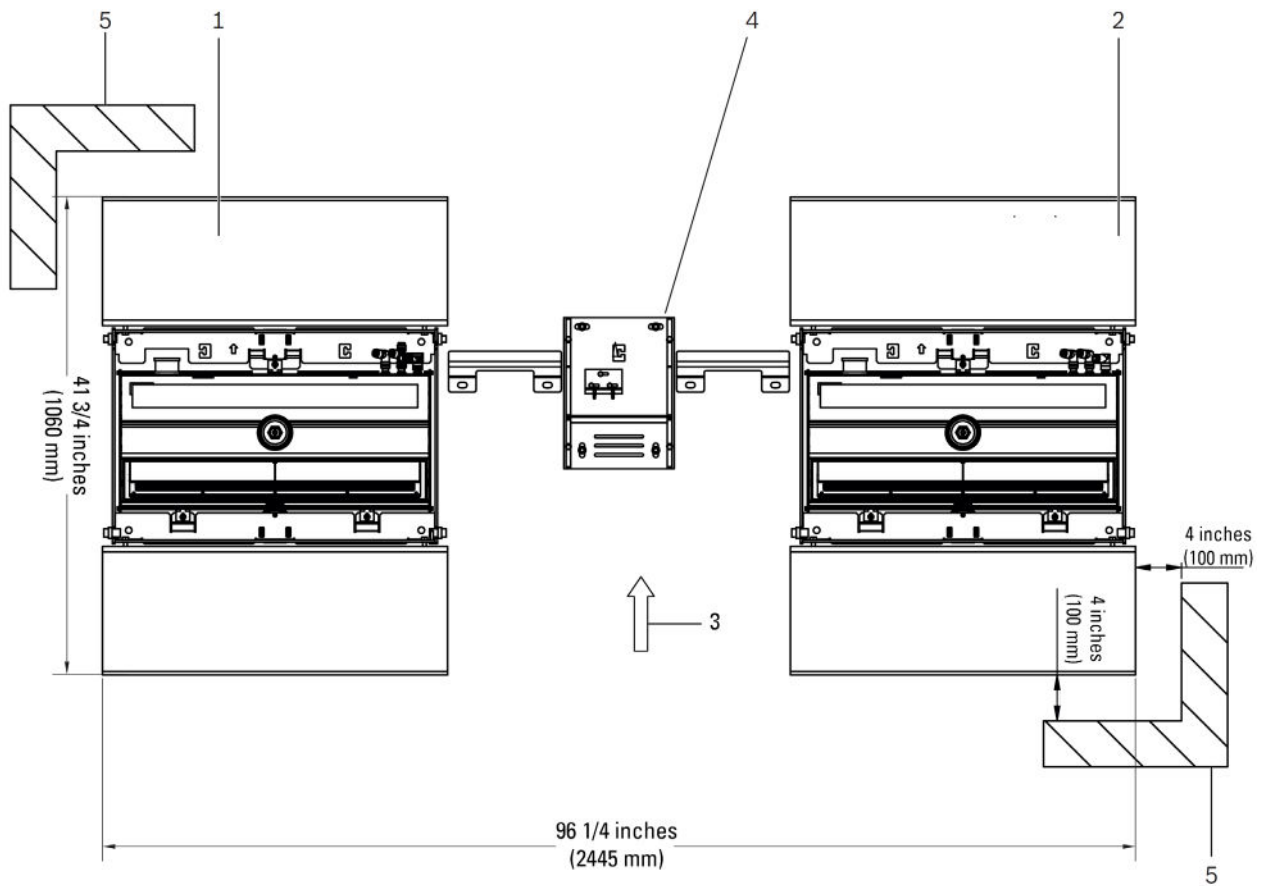

Fig. 3: Dimensions Tread Scanner in mm

- 1 Master
- 2 Satellite
- 3 Direction of crossing
- 4 Camera housing
- 5 Marking for hazard zone

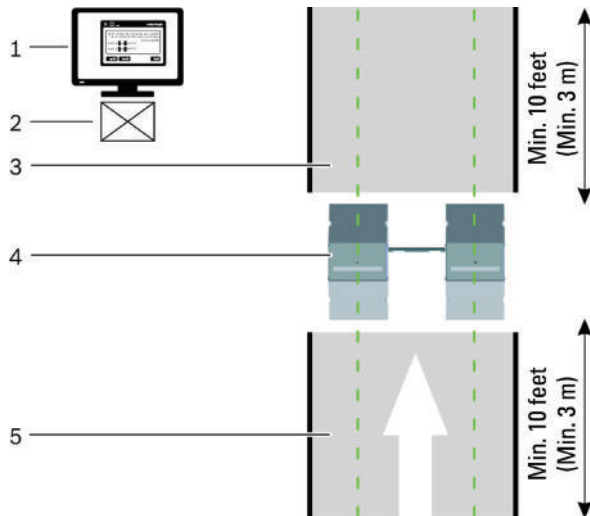

Fig. 4: Dimensions Of Measurement Bay

No.	Designation	Dimension
1	Screen/Smart TV (special accessory) max. distance to Tread Scanner	26 ¼ feet (8 meter)
2	Electrical cabinet/Switch and access point - max. distance to Tread Scanner	26 ¼ feet (8 meter)
3	Straight drive-down path, min. length	10 feet (3 meter)
4	"Master" measuring unit	3 ½ to 8 feet
5	"Satellite" measuring unit	(1.06 x 2.445 meter)
6	Straight drive-down path, min. length	10 feet (3 meter)

Set-up Tread Scanner and Camera

➤ Both modules connected directly via network.



This installation is not suited to be set up on a working pit.

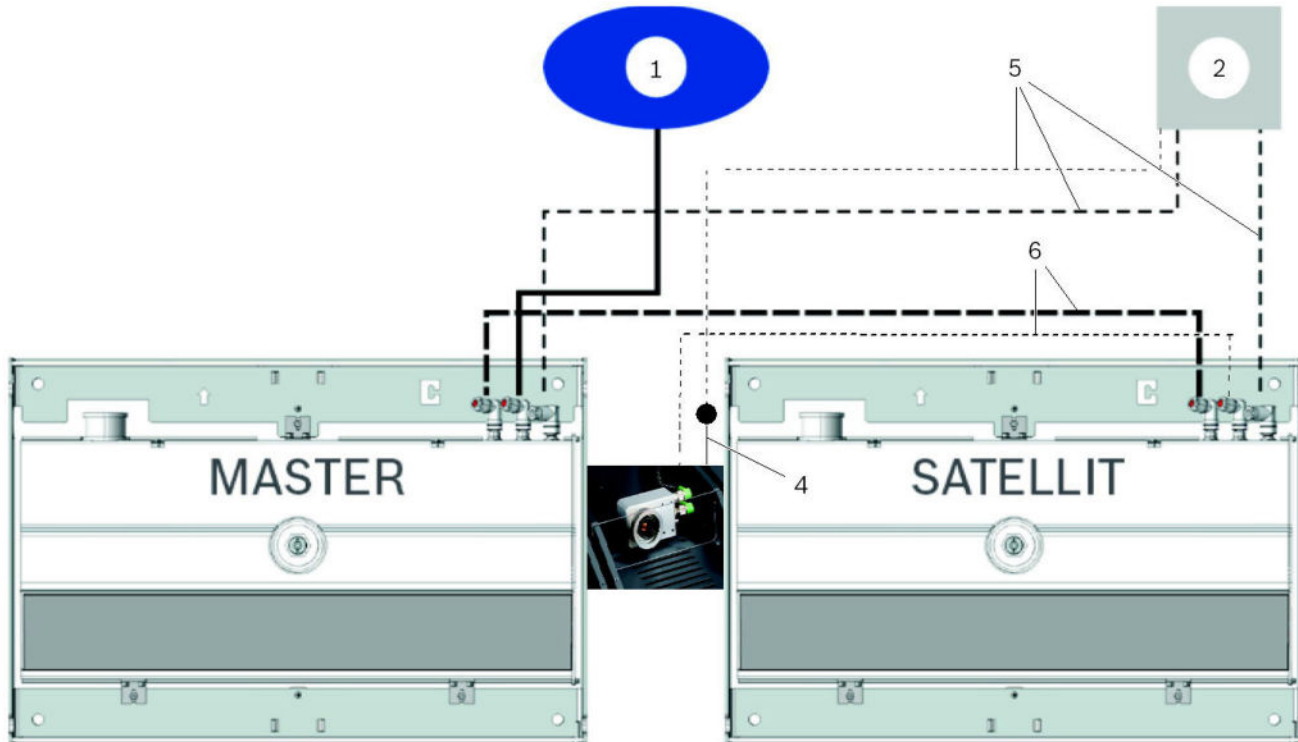

Fig. 5: Connecting the master and satellite to the network

1 Computer (optional: Digital Signage)

2 Electrical cabinet

3 Direction of travel

4 Adapter cable

5 Connection cable

6 Data cable

Installation Tread Scanner on Floor

- For installation on working pit.
- Connect both modules individually to external switch.
- No Camera possible.

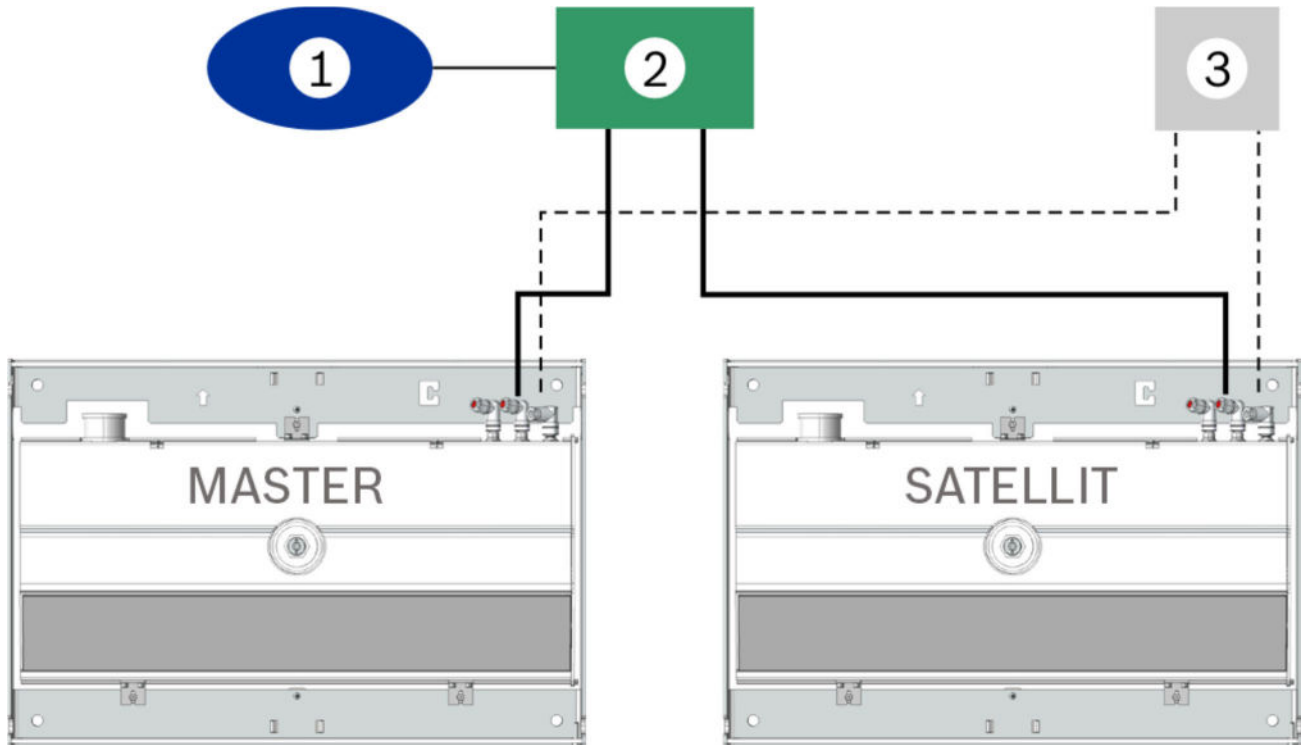

Fig. 6: Connecting both modules individually to external switch

1 Computer (optional: Digital Signage)

2 External switch

3 Electrical cabinet

4 Direction of travel

5 Connection cable

6 Data cable



This set-up is not compatible with a floor-level installation of the Tread Scanner.

Size

☐ Attach display on left or right.

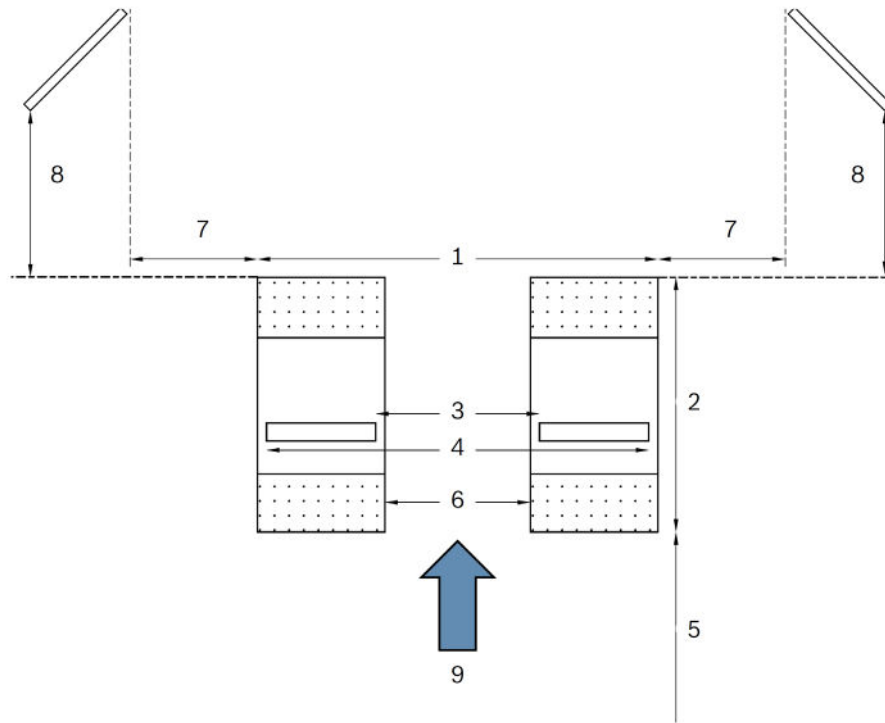

Fig. 7: Size

No.	Designation	Dimensions
Connection to quantity measurement system		
1	Max. width of measuring system	96 inches (2,445 m)
2	Max. length of measuring system	41 inches (1,040 m)
3	Min. inner track width	29 ³ / ₈ inches (0,745 m)
4	Max. outer track width	80 ⁷ / ₈ inches (2,055 m)
5	Min. access route Access route (recommended)	118 inches (3,000 m) 157 ¹ / ₂ inches (4,000 m)
6	Distance between the ramps	29 ³ / ₈ inches (0,745 m)
7	Min. distance of display (left/right) from ramp	19 ⁵ / ₈ inches (0,500 m)
8	Distance of Smart TV from ramp Setup of version A	29 ¹ / ₂ feet (9,000 m)
8	Distance of Smart TV from ramp Setup of version B	24 ¹ / ₂ feet (7,500 m)
9	Direction of crossing	—

Tab. 1: Size

☐ When positioning the ramp, do not place Tread Scanner in dirt and moisture.

Foundation Layout

☐ Only for Tread Scanner floor-level.

☐ All dimensions in cm.

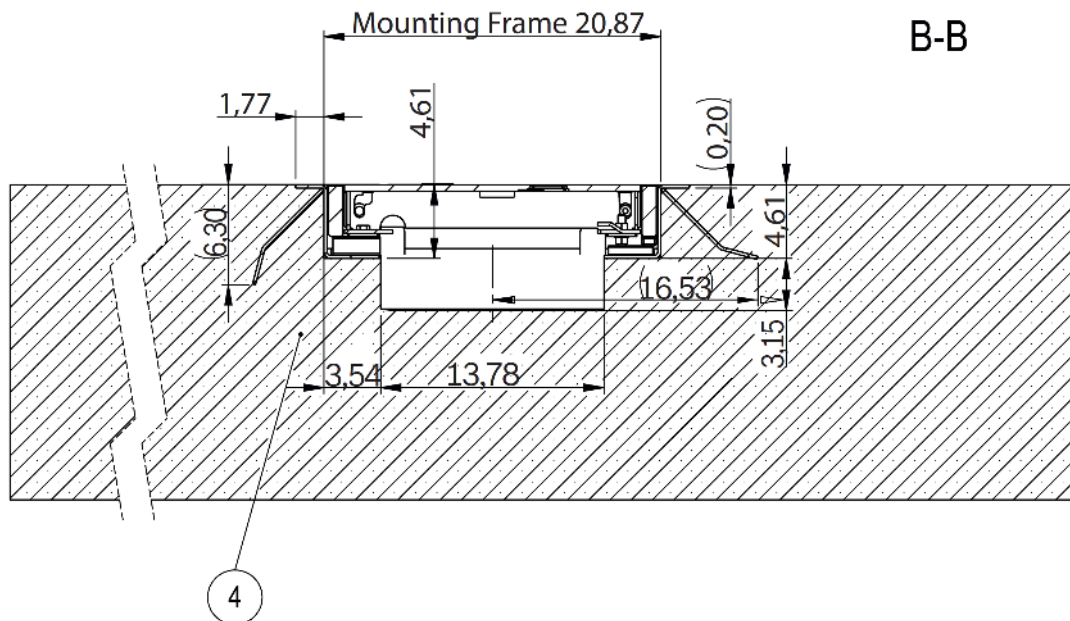
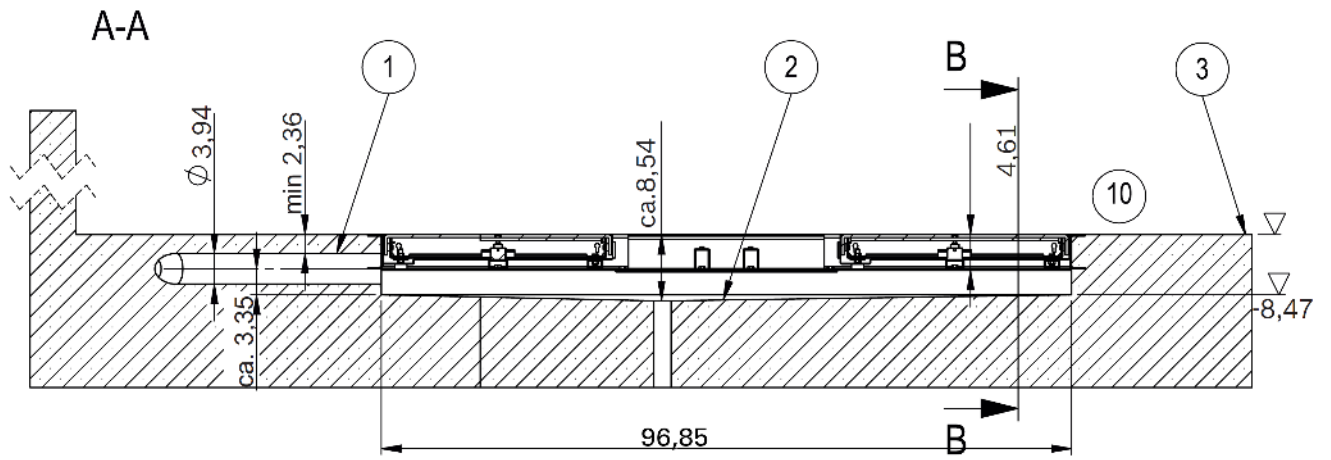

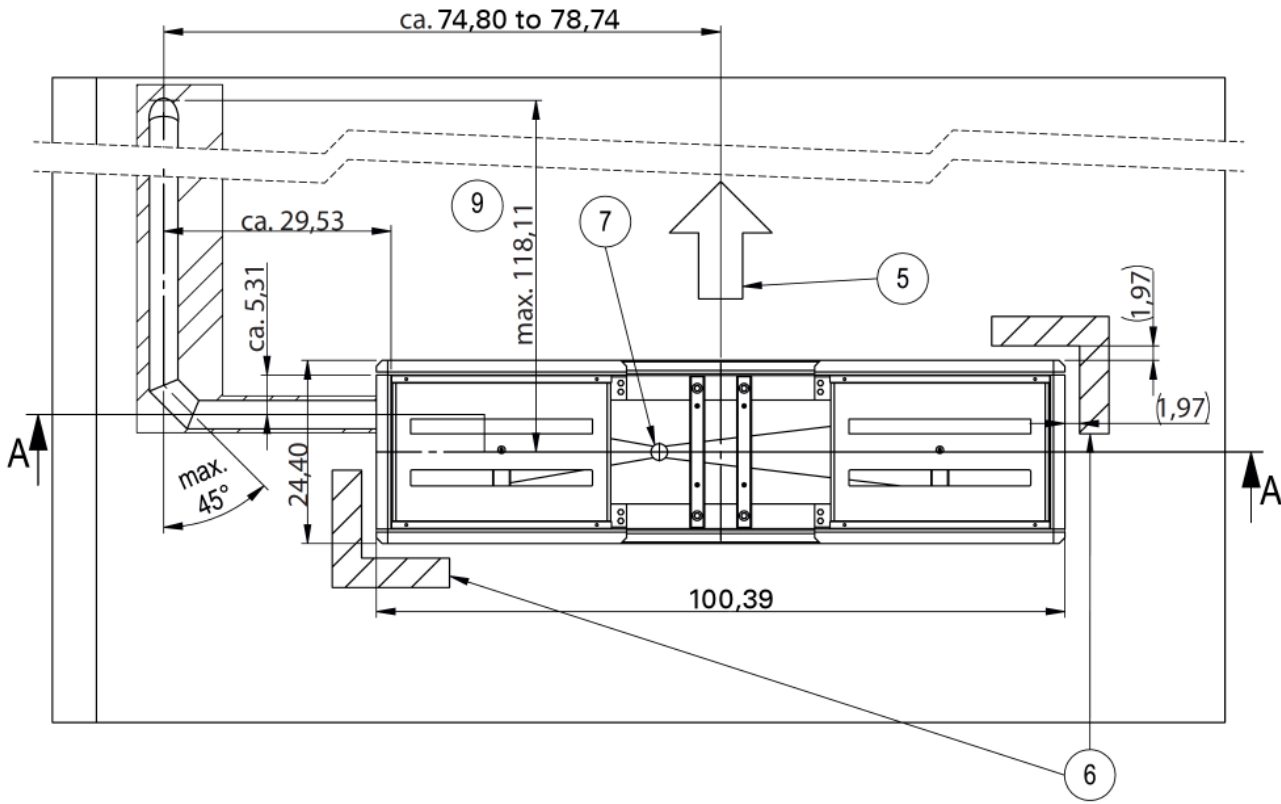

Item	Description	Remark
1	Cable conduit to the electrical cabinet	Laying bends of min. \varnothing 80; Max. 45°
2	Grade to water drain (about 2%)	
3	Finished floor top edge	OKFFB
4	Concrete quality min. C20/25 (DIN EN 19992-1-1)	
5	Crossing direction	As reference
6	Hazard zone	Hazard area to mark the tread depth measuring device acc. to DIN 4844 T1
7	Water discharge pipe	
9	Cable length of Tread Scanner module max. 33 feet (10 m)	Observe distance to electrical cabinet
10	Horizontal finished floor level required	Max. observational error \pm 0.12 inches (3 mm); concrete base plate frame flush with OKFFB

Floor Levelness and Central Unit

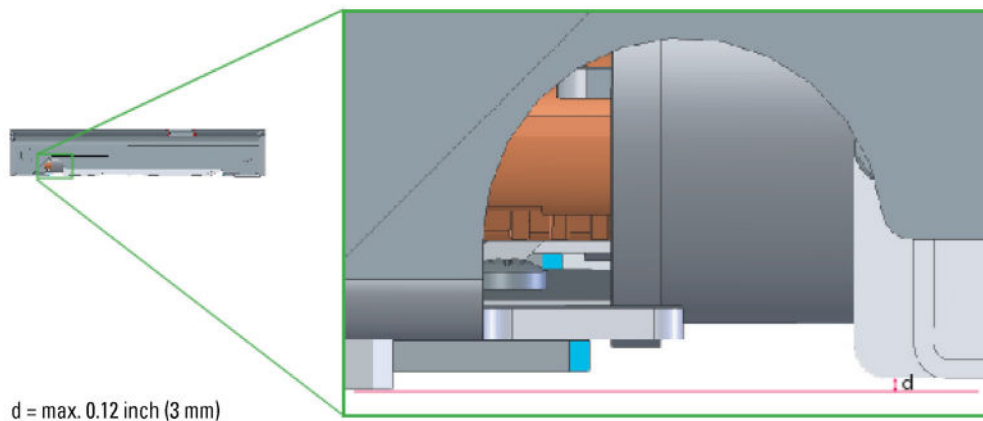
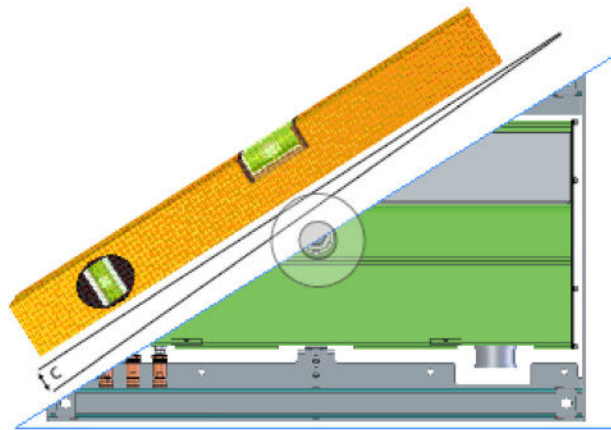
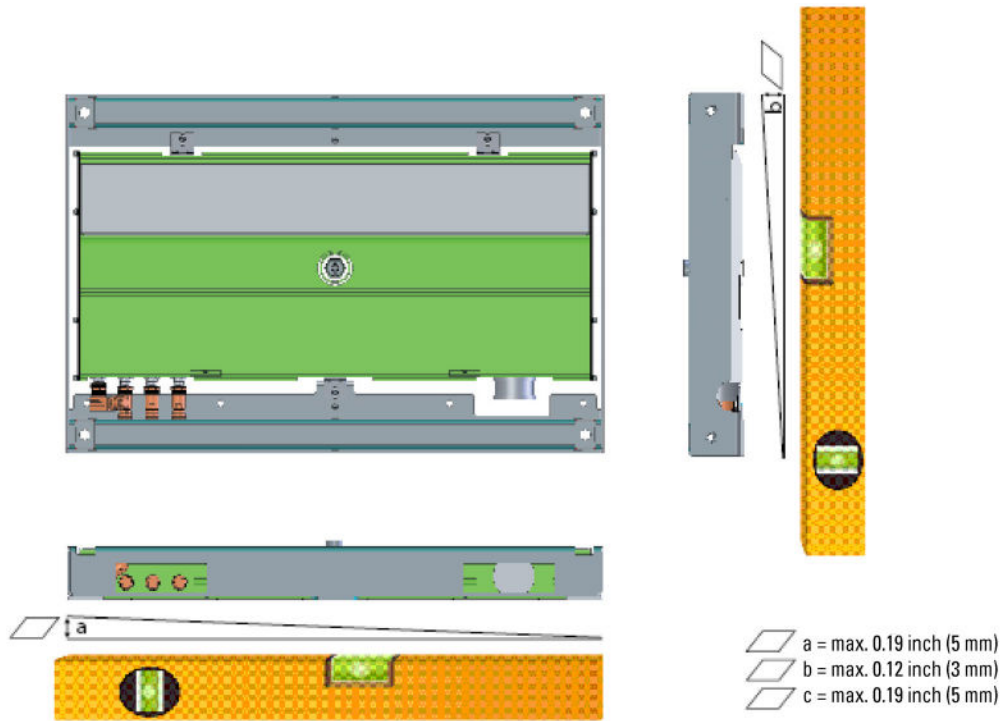

Checklist

Component	Desired IP address if deviating from 1.5
Master	
Satellite	
Camera	
Workshop PC	
Smart TV	
Number of DHCP clients	

Set-up A (installation on surface)	
1x	Electrical cabinet with 2 power supply units (PartNumber)
2x	Power supply cable Neutrik to M12, 33 feet (10 m) (85611860)
1x	Data cable M12 to M12, 8.2 feet (2.5 m) (85611859)
1x	Data cable M12 to RJ45, 33 feet (10 m) (85611858)

Set-up B (installation on working pit)	
1x	Electrical cabinet with 2 power supply units (PartNumber)
2x	Power supply cable Neutrik to M12, 33 feet (10 m) (85611860)
2x	Data cable M12 to RJ45, 33 feet (10 m) (85611858)
1x	Data cable RJ45 to RJ45, 6.5 feet (2 m) (PartNumber)
1x	External switch (PartNumber)

Supplementary equipment set Camera	
1x	1x for electrical cabinet (PartNumber)
1x	Cable set (85611863)
2x	Optional filling piece with cover (PartNumber)

Desired measuring direction	
Measurement only when pulling in	<input type="checkbox"/>
Measurement when pulling in and moving out	<input type="checkbox"/>
Additional measuring direction(s)	

- If the type C13 IEC cables included in the scope of delivery do not fit, the customer must provide 2 country-specific IEC cables.
- Dimensions checked, see "Size"
- Floor levelness checked, see "Floor Levelness and Central Unit"
- Floor load-bearing capacity checked, see "General Test Conditions"
- Minimum turning curve checked, see "Avoiding Minimum Turning Curve"

