

COATS®

1185 Wheel Balancer

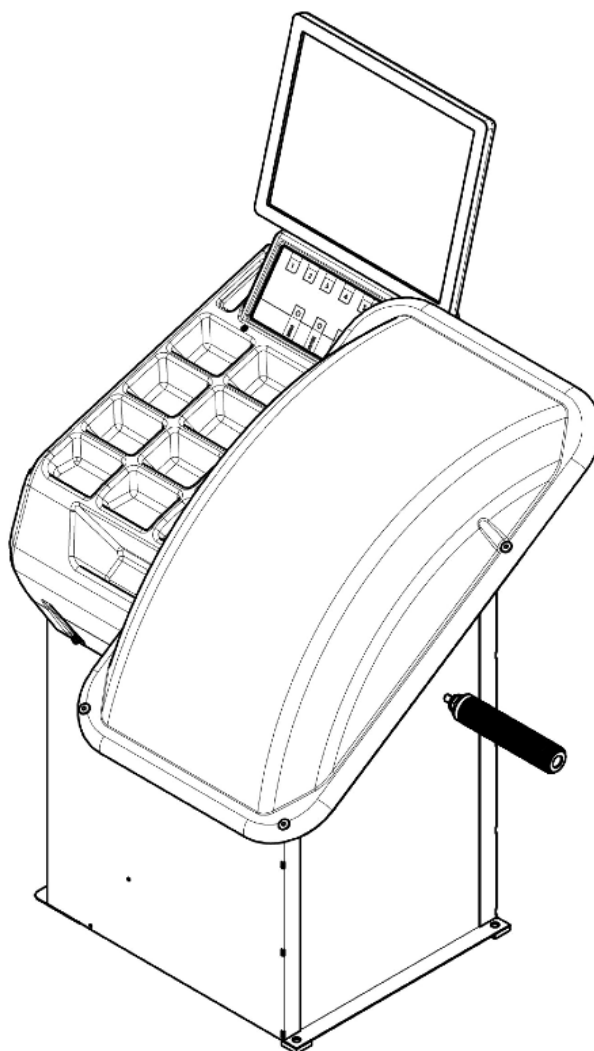

Parts Identification

READ these instructions before placing unit in service. KEEP these and other materials delivered with the unit in a binder near the machine for ease of reference by supervisors and operators.

HENNESSY
INDUSTRIES

1601 J. P. Hennessy Drive, La Vergne, TN USA 37086 615/641-7533 800/688-6359 www.coatsgarage.com
HENNESSY INDUSTRIES LLC Manufacturer of COATS®, AMMCO® and BADA® Automotive Service Equipment and Tools.

Manual Part No.: 85611763 00
Revision: 8/20

Parts Identification

The following pages include parts breakdowns with exploded view illustrations to help with ordering replacement or spare kits. Assemblies are noted where it is recommended that individual parts not be ordered separately. Note that the parts view illustrations are for multiple models and not all parts shown are on all models. Every effort is made to supply accurate exploded views, however, due to interim changes in manufacturing operations, some units may not be exactly as illustrated.

Table of Contents

Monitor	3
Touch Panel	3
Weight Tray	3
Wheel Guard Assembly	4
Hood Switch	5
Laser Assembly	5
Threaded Shaft	6
Complete Spindle 115V	6
A & D Arm Assembly	7
Index Gauge	7
Encoder	8
115V Transformer	9
Power Board	9
Electrical Schematic	10-11

Monitor

Item No	Part No.	Description
1	8801100192	17" Monitor SPST

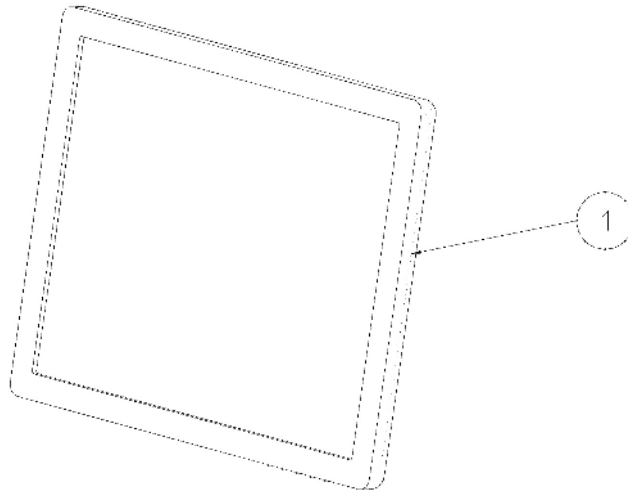

Touch Panel

Item No	Part No.	Description
1	805PR031648	Membrane Panel SPST

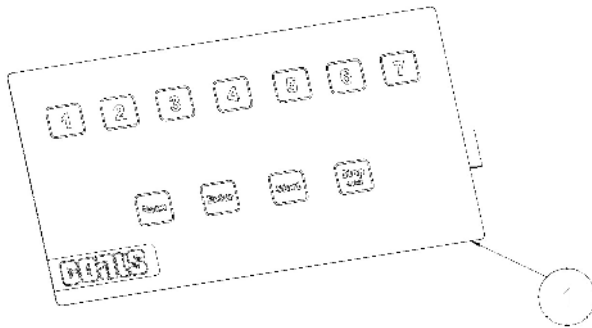

Weight Tray

Item No	Part No.	Description
1	814FB026139	Weight Tray SP ... NS

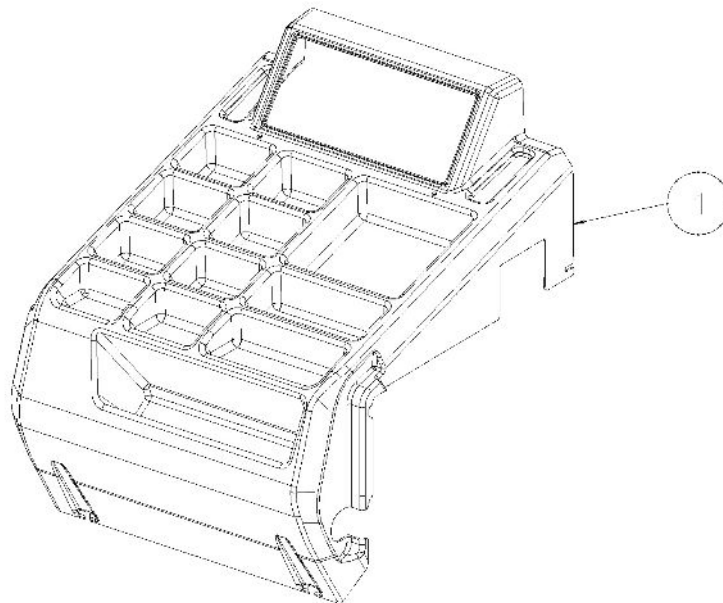

NA Not Available
NS Non-stocking
SP Service Part
ST Stock

Wheel Guard Assembly

Item No	Part No.	Description
1	814FW019964	Wheel Guard..... SP... NS
2	818FW023250	Spring SP....ST
3	8217019275	Bushing..... SP....ST
4	842FW018279	Internal Pipe..... SP... NS
5	842FW018809	Wheel Guard Support SP... NS
6	842FW023266	Ring SP....ST
7	846FW003503	Ring with Magnet SP....ST

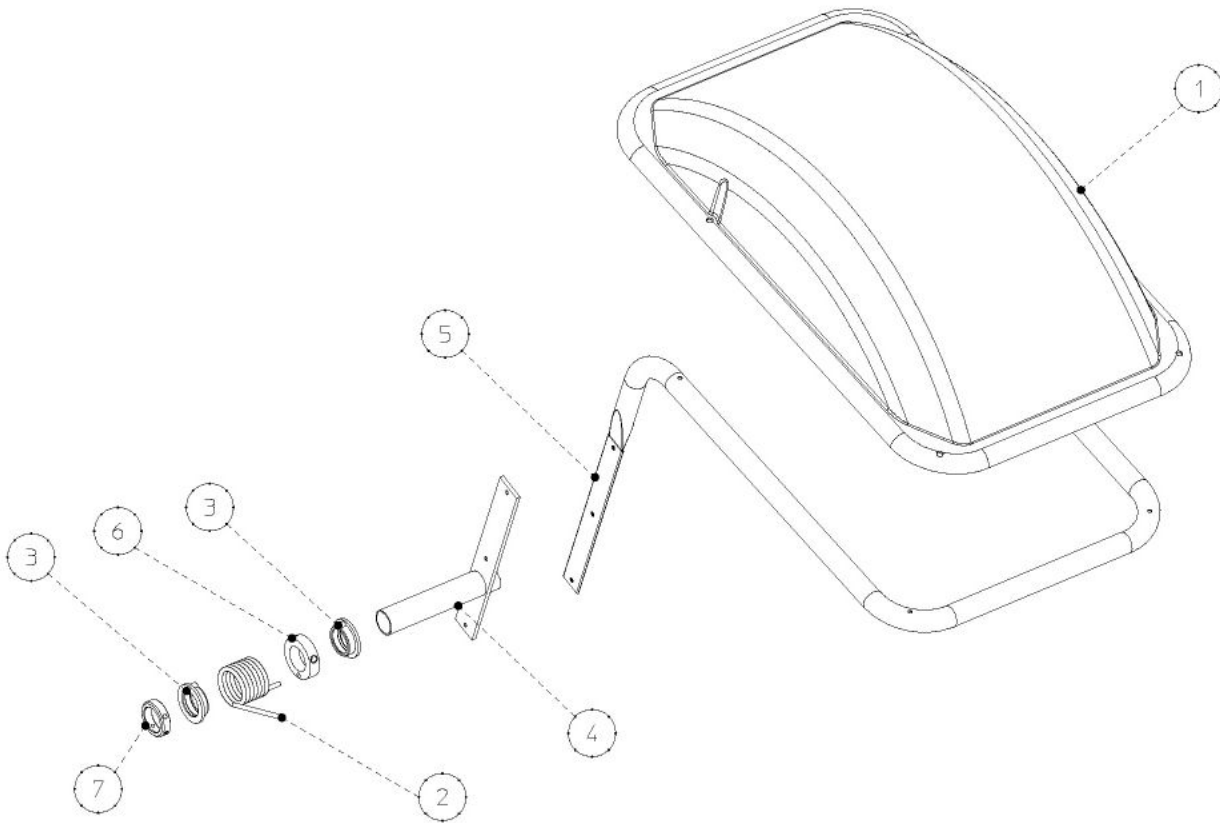

NA **Not Available**
NS **Non-stocking**
SP **Service Part**
ST **Stock**

Hood Switch

Item No	Part No.	Description
1	886SB023305	Magnetic Switch..... SPST
2	886SB023307	Magnetic Switch..... SPST

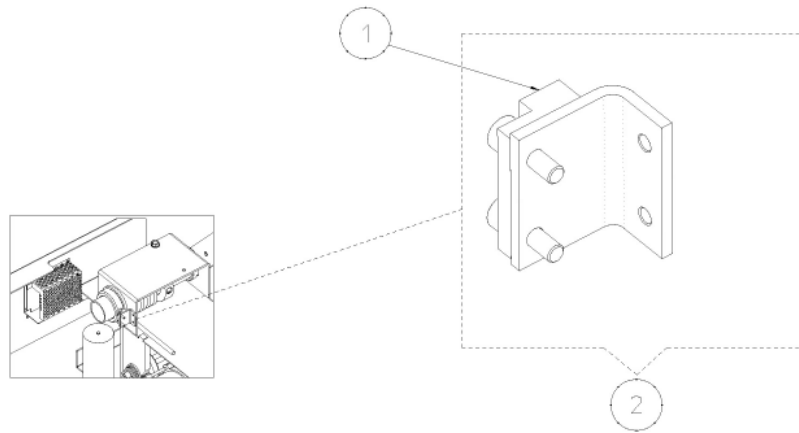

Laser Assembly

Item No	Part No.	Description
1	814RS95438	Laser Bracket..... SPST
2	8312120038	Screw..... SPST
3	886SBA1124	Laser..... SPST

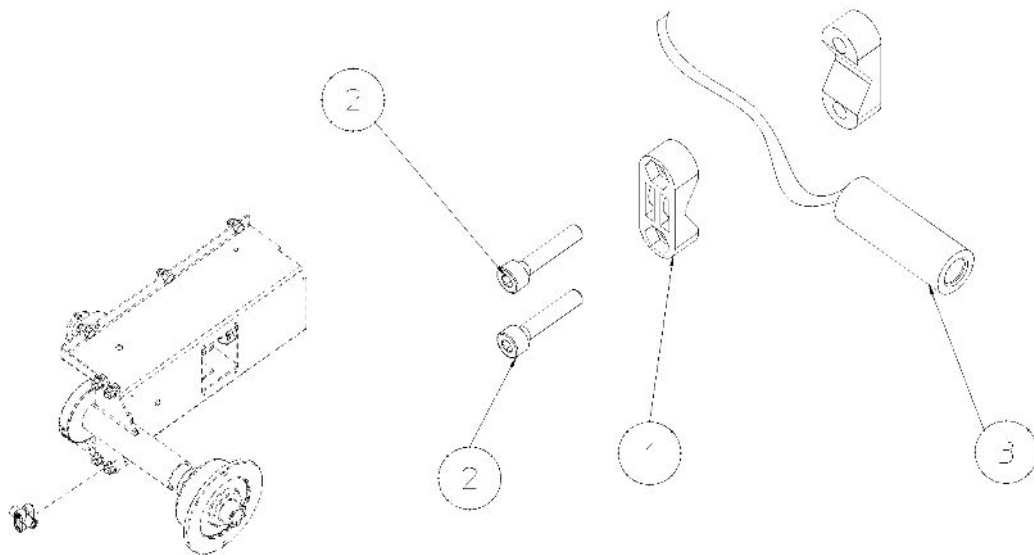

NA Not Available
NS Non-stocking
SP Service Part
ST Stock

Threaded Shaft

Item No	Part No.	Description
1	85009009	Threaded Shaft Assy..... SP....ST

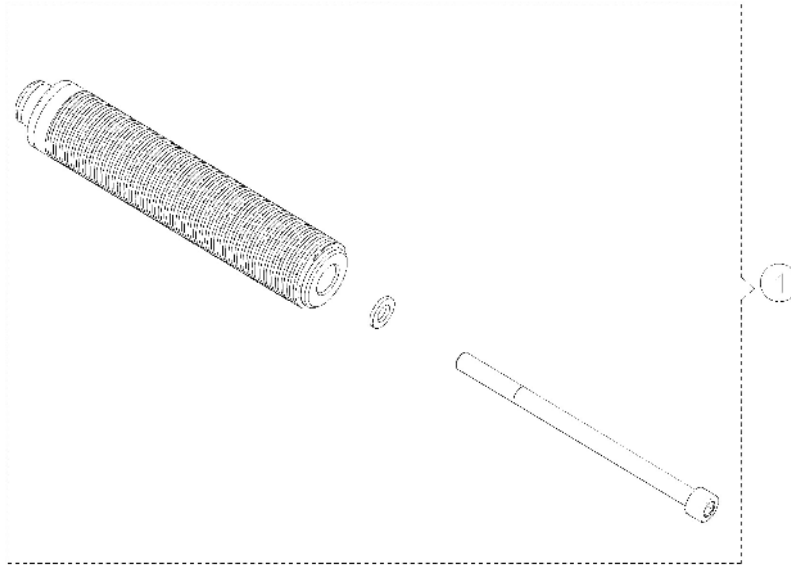

Complete Spindle 115V

Item No	Part No.	Description
1	8080048009	Belt SP....ST
2	850FG028974	Motor..... SP....ST
3	8090100004	Transformer 115V..... SP....ST
4	8568003558	Capacitor 115V..... SP....ST
5	846FB028975	Complete spindle 115V.... SP....ST

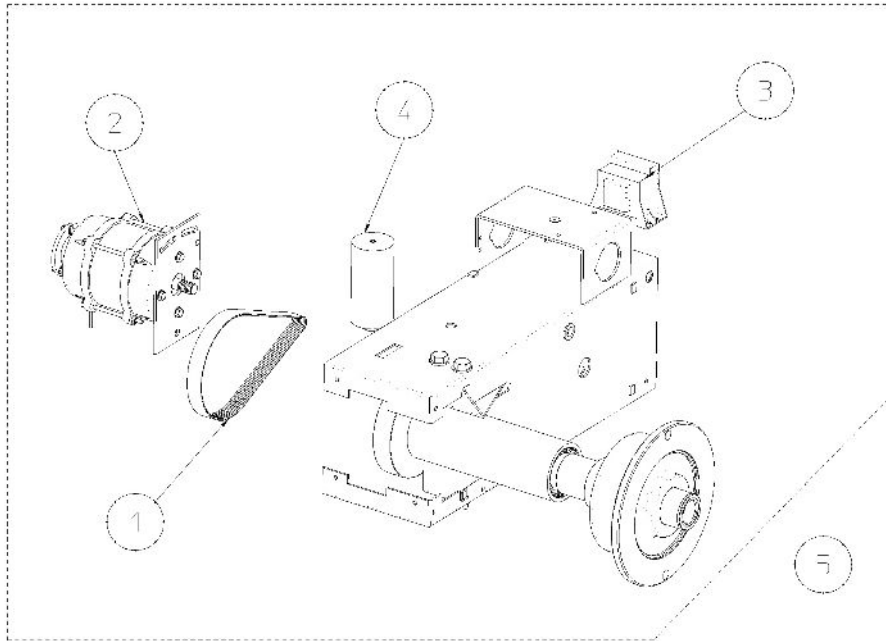

NA **Not Available**
NS **Non-stocking**
SP **Service Part**
ST **Stock**

A & D Arm Assembly

Item No	Part No.	Description
1	842FB018023	Bracket.....SP...NS
2	842FC018024	RodSP...NS
3	886SB67291	Potentiometer.....SP....ST

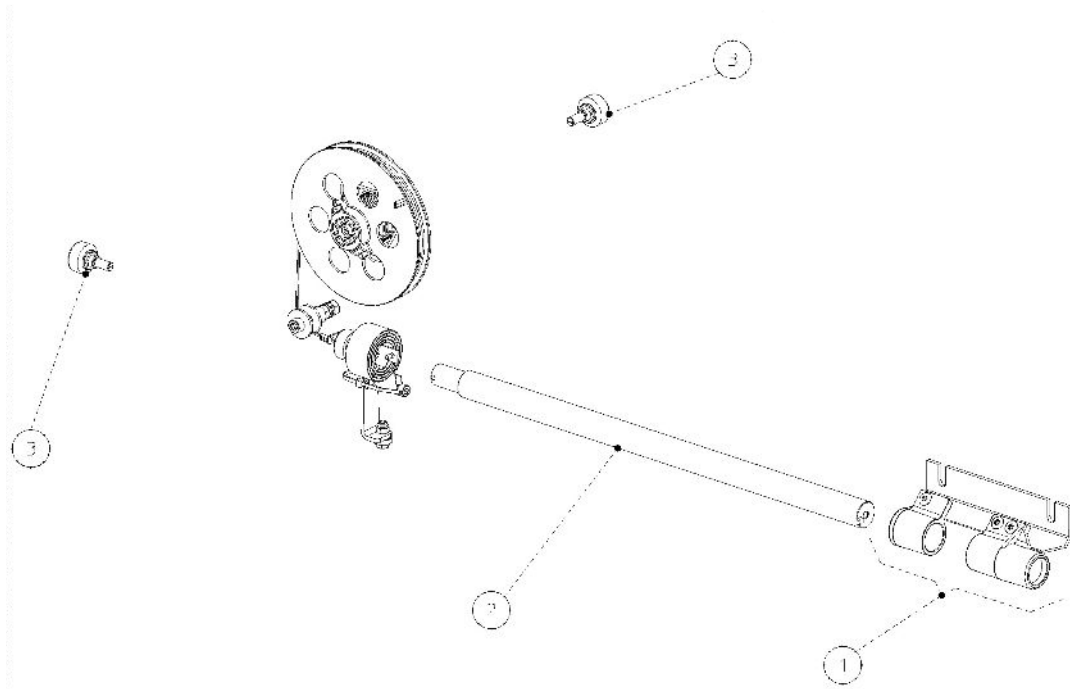

Index Gauge

Item No	Part No.	Description
1	8312120069	Screw N/A
2	846FC92123	Arm-Gauge,IndxSP...NS

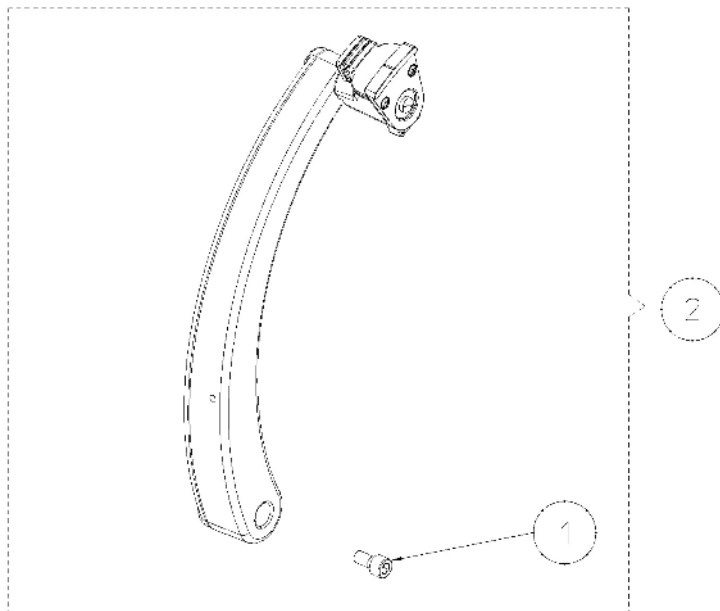

NA Not Available
NS Non-stocking
SP Service Part
ST Stock

Encoder

Item No	Part No.	Description
1	818FB76761	Traction SpringSP....ST
2	886SD028551	EncoderSP....ST

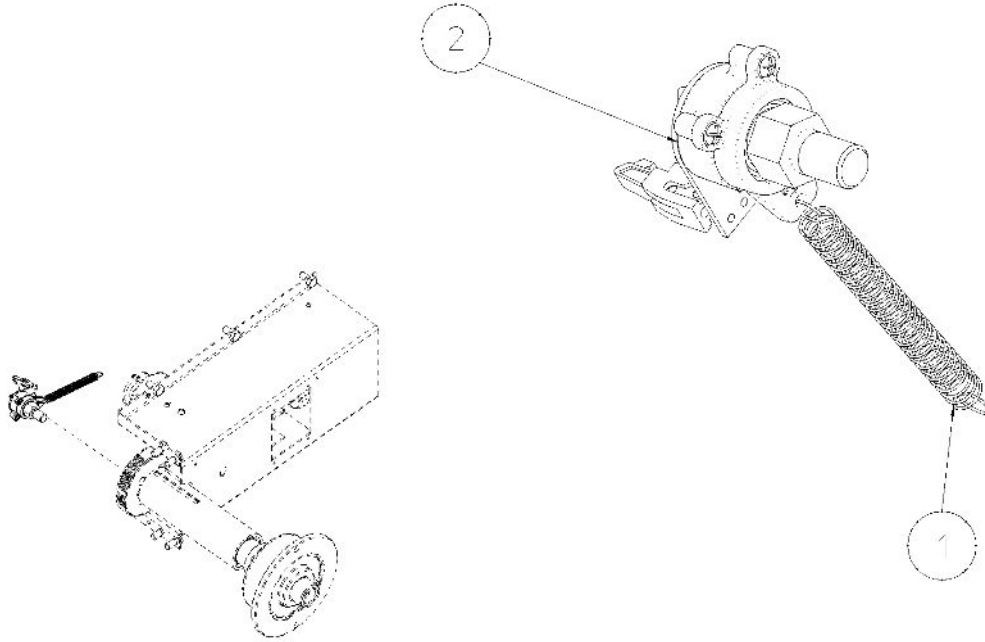

NA Not Available
NS Non-stocking
SP Service Part
ST Stock

115V Transformer

Item No	Part No.	Description
1	8090100004	Transformer 115V.....SP....ST

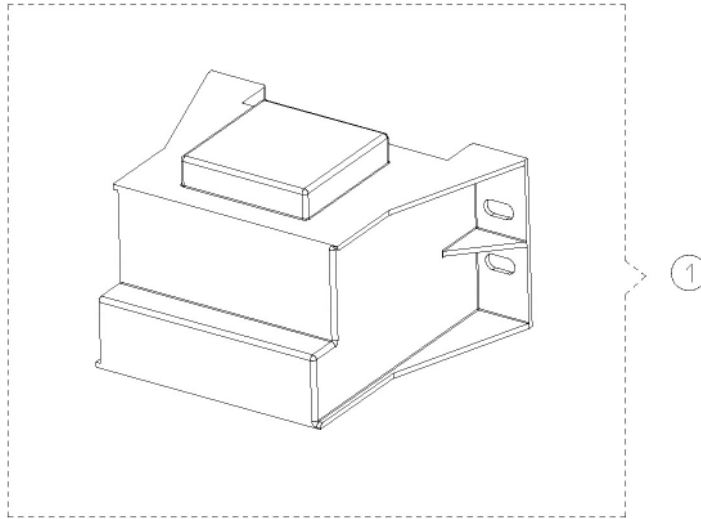

Power Board

Item No	Part No.	Description
1	886SZ021156	Power Supply 12VDC.....SP....ST
2	886SC034331	Processor CardSP....ST
3	867D100058B	Power BoardSP....ST

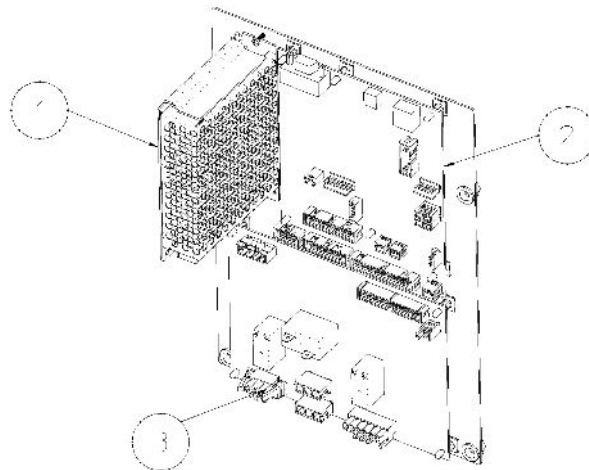

NA **Not Available**
NS **Non-stocking**
SP **Service Part**
ST **Stock**

Electrical Schematic

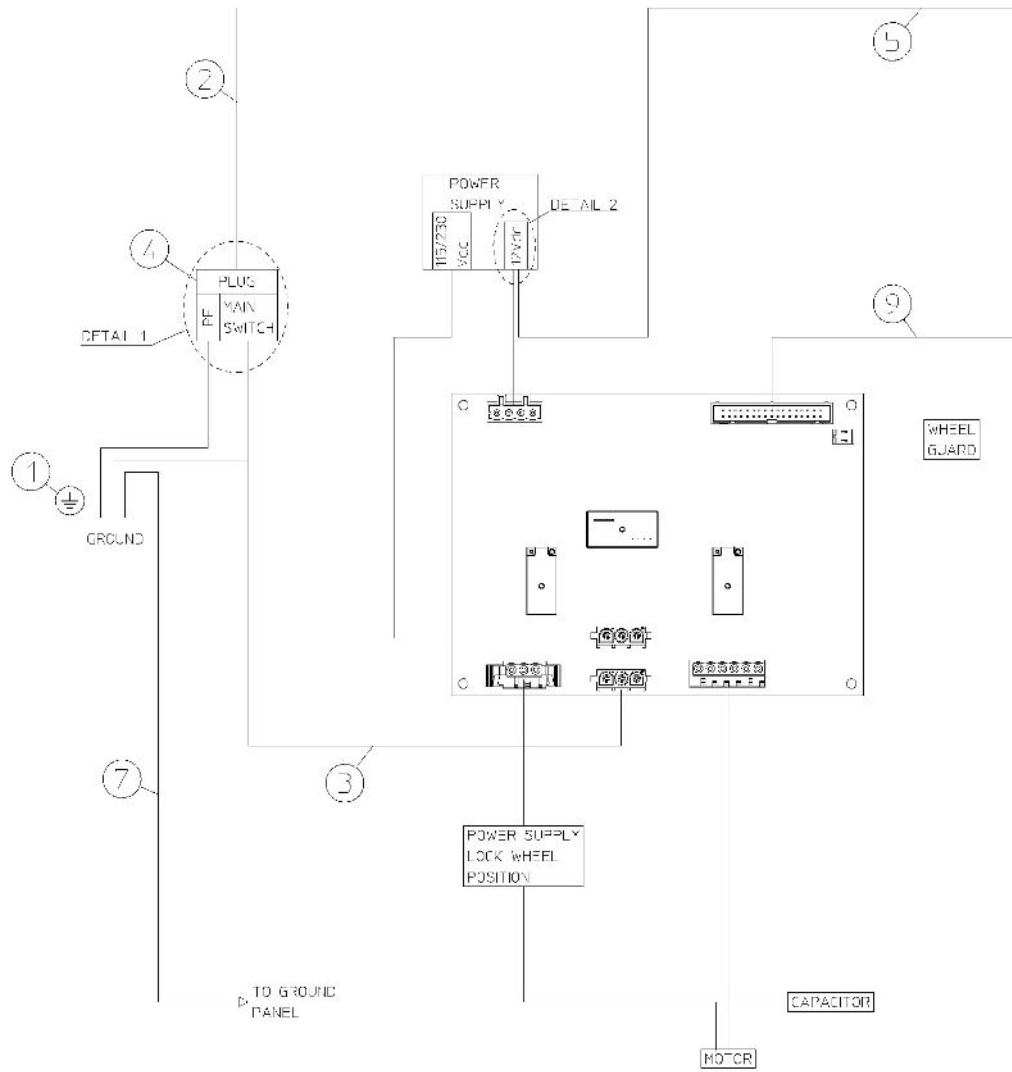

Item No	Part No.	Description
2	886SB018249	Power Plug.....SP....ST
3	886SB021174	Cable.....SP....ST
4	85101000080	Rocker Switch.....SP....ST
5	886SB026727	Power Cable.....SP....ST
6	886SB39191	Wiring.....SP....ST
7	86SB63471	Ground Wiring.....NA
8	86SB75461	Flat Cable.....NA
9	886SBA2000	Wiring.....SP....ST

NA Not Available
NS Non-stocking
SP Service Part
ST Stock

Electrical Schematic

