

# COATS®

## Model 1300-2D

### Wheel Balancer



See  
★ **Balancing Your  
First Tire**  
on page 4.

**Safety Instructions**  
**Set-up Instructions**  
**Operation Instructions**  
**Maintenance Instructions**

READ these instructions before placing unit in service. KEEP these and other materials delivered with the unit in a binder near the machine for ease of reference by supervisors and operators.

**HENNESSY  
INDUSTRIES**

1601 J. P. Hennessy Drive, LaVergne, TN USA 37086 615/641-7533 800/688/6359 www.coatsgarage.com  
HENNESSY INDUSTRIES LLC. Manufacturer of COATS®, AMMCO® and BADA® Automotive Service Equipment and Tools.

Manual Part No.: 85610936 02  
Revision: 2/20

# IMPORTANT SAFETY INSTRUCTIONS

## READ ALL INSTRUCTIONS

1. Eye and face protection recommendations:  
“Protective eye and face equipment is required to be used where there is a reasonable probability of injury that can be prevented by the use of such equipment.” O.S.H.A. 1910.133(a) Protective goggles, safety glasses, or a face shield must be provided by the owner and worn by the operator of the equipment. Care should be taken to see that all eye and face safety precautions are followed by the operator. ALWAYS WEAR SAFETY GLASSES. Everyday glasses only have impact resistant lenses, they are not safety glasses.
2. Do not disable hood safety interlock system, or in any way shortcut safety controls and operations.
3. Be sure that wheels are mounted properly, the hub nut engages the arbor for not less than four (4) turns, and the hub nut is firmly tightened before spinning the wheel.
4. Read and understand this manual before operating. Abuse and misuse will shorten the functional life.
5. Be sure the balancer is properly connected to the power supply and electrically grounded.
6. Do not operate equipment with a damaged cord or if the equipment has been dropped or damaged – until it has been examined and repaired by a qualified serviceman.
7. Do not let cord hang over edge of table, bench, or counter or come in contact with hot manifolds or moving fan blades.
8. If an extension cord is necessary, a cord with a current rating equal to or more than that of the equipment should be used. Cords rated for less current than the equipment may overheat. Care should be taken to arrange the cord so that it will not be tripped over or pulled.
9. Keep guards and safety features in place and in working order.
10. Wear proper clothing. Safety toe, non-slip footwear and protective hair covering to contain hair is recommended. Do not wear jewelry, loose clothing, neckties, or gloves when operating the balancer.
11. Keep work area clean and well lighted. Cluttered and/or dark areas invite accidents.
12. Avoid dangerous environments. Do not use power tools or electrical equipment in damp or wet locations, or expose them to rain.
13. Avoid unintentional starting. Be sure the balancer is turned off and power disconnected before servicing.
14. Disconnect the balancer before servicing.
15. Use only manufacturer’s recommended accessories. Improper accessories may result in personal injury or property damage.
16. Repair or replace any part that is damaged or worn and that may cause unsafe balancer operation. Do not operate damaged equipment until it has been examined by a qualified service technician.
17. Never overload or stand on the weight tray or any part of the balancer.
18. Do not allow untrained persons to operate machinery.
19. To reduce the risk of fire, do not operate equipment in the vicinity of open containers or flammable liquids (gasoline).
20. Adequate ventilation should be provided when working on or operating internal combustion engines.
21. Keep hair, loose clothing, fingers, and all parts of body away from moving parts.
22. Use equipment only as described in this manual.
23. Use only manufacturer’s recommended attachments and accessories.

## SAVE THESE INSTRUCTIONS

## Owner's Responsibility

To maintain machine and user safety, the responsibility of the owner is to read and follow these instructions:

- Follow all installation instructions.
- Make sure installation conforms to all applicable Local, State, and Federal Codes, Rules, and Regulations; such as State and Federal OSHA Regulations and Electrical Codes.
- Carefully check the unit for correct initial function.
- Read and follow the safety instructions. Keep them readily available for machine operators.
- Make certain all operators are properly trained, know how to safely and correctly operate the unit, and are properly supervised.
- Allow unit operation only with all parts in place and operating safely.
- Carefully inspect the unit on a regular basis and perform all maintenance as required.
- Service and maintain the unit only with authorized or approved replacement parts.
- Keep all instructions permanently with the unit and all decals/labels/notices on the unit clean and visible.
- Do not override safety features.

## Operator Protective Equipment

Personal protective equipment helps make tire servicing safer. However, equipment does not take the place of safe operating practices. Always wear durable work clothing during tire service activity. Loose fitting clothing should be avoided. Tight fitting leather gloves are recommended to protect operator's hands when handling worn tires and wheels. Sturdy leather work shoes with steel toes and oil resistant soles should be used by tire service personnel to help prevent injury in typical shop activities. Eye protection is essential during tire service activity. Safety glasses with side shields, goggles, or face shields are acceptable. Back belts provide support during lifting activities and are also helpful in providing operator protection. Consideration should also be given to the use of hearing protection if tire service activity is performed in an enclosed area, or if noise levels are high.

## Definitions of Hazard Levels

Identify the hazard levels used in this manual with the following definitions and signal words:

### DANGER

Watch for this symbol:



It Means: Immediate hazards, which will result in severe personal injury or death.

### WARNING

Watch for this symbol:



It Means: Hazards or unsafe practices, which could result in severe personal injury or death.

### CAUTION

Watch for this symbol:



It Means: Hazards or unsafe practices, which may result in minor personal injury or product or property damage.



Watch for this symbol! It means BE ALERT! Your safety, or the safety of others, is involved!

## Safety Notices and Decals



Failure to follow danger, warning, and caution instructions may lead to serious personal injury or death to operator or bystander or damage to property. Do not operate this machine until you read and understand all the dangers, warnings and cautions in this manual. For additional copies of either, or further information, contact:

### Hennessy Industries LLC

1601 JP Hennessy Drive  
LaVergne, TN 37086  
(615) 641-7533 or (800) 688-6359  
www.coatsgarage.com



<b>WARNING</b>	<b>AVERTISSEMENT</b>
<p><b>RISK OF EXPLOSION</b></p> <p>This equipment has internal arcing or sparking parts which should not be exposed to flammable vapors. Do not locate in a recessed area or below floor level.</p> <p><b>THIS EQUIPMENT MUST BE EARTH-GROUNDED</b></p> <p>The earth-ground connector built into the power cord provides protection to reduce the risk of electrical shock.</p>	<p><b>RISQUE D'EXPLOSION</b></p> <p>Cet équipement possède des pièces internes, pouvant lancer des arcs ou jeter des étincelles, et qui ne devraient pas être exposées à des vapeurs inflammables. Ne situez pas l'équipement dans des endroits encastrés ou en-dessous du niveau du plancher.</p> <p><b>CET ÉQUIPEMENT DOIT ÊTRE MIS À LA TERRE</b></p> <p>Le raccord de mise à la terre incorporé dans le cordon de puissance fournit une protection afin de réduire le risque d'électrocution.</p>
<b>CAUTION</b>	<b>ATTENTION</b>
<p>Do not use below garage floor or grade level.</p> <p>Disconnect power before servicing this equipment.</p> <p>To prevent electrical shock, do not remove cover. No user serviceable parts inside. Refer servicing to qualified service personnel.</p>	<p>N'utilisez pas en-dessous du plancher du garage ou du palier.</p> <p>Débranchez le cordon de puissance avant de faire l'entretien de cet équipement.</p> <p>Afin de vous protéger contre l'électrocution, n'enlevez pas le couvercle. Aucune pièce interne ne nécessite d'entretien par l'utilisateur. Référez l'entretien à un personnel de service qualifié.</p>

## Standard Safety Devices



Never raise up the wheel guard before the wheel has come to a stop. Keep hair, loose clothing, fingers and all parts of body away from moving parts.

- STOP key for stopping the wheel under emergency conditions.
- A hood guard of high impact plastic that is designed to prevent the counterweights from flying out in any direction except towards the floor.
- A hood switch interlock system that prevents the machine from starting if the guard is not lowered and stops the wheel whenever the guard is raised.

**WARNING**

**Maximum Size of Wheel Rating**

Weight	Diameter	Width
90 lbs./40 kg	42 in./107 cm	19 in./48cm

Maximum Duty Cycle

**30 Wheels/Hour @ 90 lbs./40 kg**

85610497 00

Arabic & Australian Models Only

**WARNING**

**Risk of Injury**

This machine is provided with a wheel guard interlock. Do not defeat it's purpose.

8111840 02

**AVERTISSEMENT**

**Danger de Blessures**

Cet appareil est livré avec un verrouillage du garde de la roue. Ne nuisez pas à son fonctionnement.

8111840FR 02

<b>WARNING</b>	<b>AVERTISSEMENT</b>												
<p><b>Maximum Size of Wheel Rating</b></p> <table style="margin-left: auto; margin-right: auto;"> <tr> <td style="padding: 0 10px;">Weight</td> <td style="padding: 0 10px;">Diameter</td> <td style="padding: 0 10px;">Width</td> </tr> <tr> <td style="padding: 0 10px;">160 lbs.</td> <td style="padding: 0 10px;">44 in.</td> <td style="padding: 0 10px;">20 in.</td> </tr> </table> <p style="text-align: center; margin-top: 10px;">Maximum Duty Cycle</p> <p style="text-align: center; font-size: 1.2em;"><b>30 Wheels/Hour @ 160 lbs.</b></p>	Weight	Diameter	Width	160 lbs.	44 in.	20 in.	<p><b>Capacité de la Dimension Maximale de la Roue</b></p> <table style="margin-left: auto; margin-right: auto;"> <tr> <td style="padding: 0 10px;">Poids</td> <td style="padding: 0 10px;">Diamètre</td> <td style="padding: 0 10px;">Largeur</td> </tr> <tr> <td style="padding: 0 10px;">73Kg</td> <td style="padding: 0 10px;">111,8cm</td> <td style="padding: 0 10px;">50,8cm</td> </tr> </table> <p style="text-align: center; margin-top: 10px;">Cycle de Service Maximum</p> <p style="text-align: center; font-size: 1.2em;"><b>30 Roues/Heure @ 73Kg</b></p>	Poids	Diamètre	Largeur	73Kg	111,8cm	50,8cm
Weight	Diameter	Width											
160 lbs.	44 in.	20 in.											
Poids	Diamètre	Largeur											
73Kg	111,8cm	50,8cm											

85610679 00

# Table of Contents

Owner's Responsibility .....	iii	<b>Direct Select™ Weight Location</b> .....	<b>12</b>
Operator Protective Equipment .....	iii	<b>Setting Wheel Dimensions (DIM)</b> .....	<b>12</b>
Definitions of Hazard Levels .....	iii	Definition of Dimensions (DIM) .....	12
Safety Notices and Decals .....	iv	Basic Wheel Data Entry .....	13
Standard Safety Devices .....	iv	Entering Wheel Dimensions Manually .....	13
<b>Set Up Instructions</b> .....	<b>2</b>	<b>Balancing A Wheel</b> .....	<b>14</b>
Receiving.....	2	Dynamic Balancing.....	14
Electrical Requirements .....	2	Static Balancing.....	14
Machine Set Up .....	2	Behind Spoke Mode .....	15
Floor and Space Requirements.....	2	<b>Corrective Weight Placement</b> .....	<b>15</b>
Connect to Power .....	2	<b>Match Balance (Optimization)</b> .....	<b>16</b>
<b>Specifications</b> .....	<b>3</b>	Match Balance Mode.....	16
<b>Features</b> .....	<b>3</b>	<b>Calibration Program</b> .....	<b>17</b>
<b>Accessory Options</b> .....	<b>3</b>	Machine Calibration .....	17
Basic Accessory Kit 85009974 .....	3	Arm Calibration .....	18
<b>★Balancing Your First Tire</b> .....	<b>4</b>	<b>Maintenance Instructions</b> .....	<b>19</b>
<b>Principle Operating Parts</b> .....	<b>5</b>	<b>Diagnostic Procedures</b> .....	<b>20</b>
Know Your Unit .....	5	After Balance Vibration Problems .....	20
Power Switch.....	6	Troubleshooting.....	20
Using The Offset Arm.....	6	<b>Glossary</b> .....	<b>22</b>
Control Panel Layout.....	8		
Control Panel Function and Review .....	8		
<b>Mounting Wheel On Balancer Shaft</b> .....	<b>10</b>		
Standard Back Cone Mounting .....	10		
Standard Front Cone Mounting.....	11		
Alternate Mounting .....	11		

	 <span style="font-size: 2em; font-weight: bold; margin-left: 10px;">NOTICE</span>
	<p style="text-align: center; margin: 0;"><b>Read entire manual before assembling, installing, operating, or servicing this equipment.</b></p>

## Set Up Instructions

### Receiving

The shipment should be thoroughly inspected as soon as it is received. The signed bill of lading is acknowledgement, for the carrier, of receipt in good condition of the shipment covered by our invoice.

If any of the goods called for on this bill of lading are shorted or damaged, do not accept them until the carrier makes a notation of the shorted or damaged goods on the freight bill. Do this for your own protection.

NOTIFY THE CARRIER AT ONCE if any hidden loss or damage is discovered after receipt and request him to make an inspection. If the carrier will not do so, prepare an affidavit to the effect that you have so notified the carrier (on a certain date) and that he has failed to comply with your request.

IT IS DIFFICULT TO COLLECT FOR LOSS OR DAMAGE AFTER YOU HAVE GIVEN THE CARRIER A CLEAR RECEIPT.

File your claim with the carrier promptly. Support your claim with copies of the bill of lading, freight bill, invoice, and photographs, if possible.

Although COATS responsibility ceases upon delivery of the shipment to the carrier, we will gladly assist in tracing lost shipments. Our willingness to assist in every possible manner does not make COATS responsible for collection of claims, or replacement of lost or damaged materials.

### Electrical Requirements

See serial tag for the appropriate power requirements of your machine.

Always have a qualified electrician install the proper receptacles in accordance with state and local codes.

## Machine Set Up



**Do not use the control panel, control panel base, accessory storage, faceplate, hood or shaft to lift the balancer.**



**Do not attempt to install and set up the unit yourself. Contact COATS as noted below.**

A factory trained COATS Service Technician must perform the install, set up, and initial test procedures on your wheel balancer. Do not attempt to install and set up the unit yourself. Accurate and reliable operation of your unit depends on proper installation. Please contact COATS directly at 1-800-688-9240 for the Certified Service Partner nearest you.

### Floor and Space Requirements

The balancer must be located on a flat floor of solid construction, preferably concrete. The balancer must sit solidly on its three feet. If the balancer is not level, does not sit solidly on its three feet, or is placed on an unstable floor, the balancer will not function properly and may produce inaccurate balance readings.

Do not operate the balancer while it is on the pallet.

Select a location for the balancer that provides a level, solid floor, and adequate clearance around and above the balancer. Make sure the location selected has enough room above and behind the unit so the hood can be raised completely. The location must also provide working room for mounting and removing wheels. Make sure the area has adequate lighting.

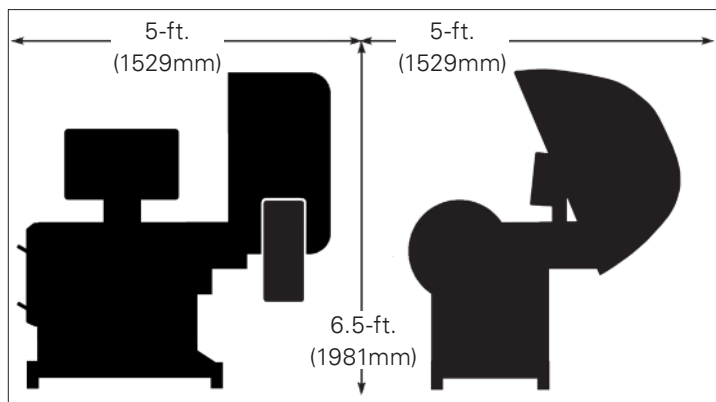

Figure 1 - Space Requirements

### Connect to Power

Your factory trained COATS® Service Technician should do the final check to verify the power installation before connecting the balancer to a power supply. Failure due to improper power connection may void the warranty.

## Specifications

### Wheel Diameter Range

8 - 30 inches (203 - 762 mm)

### Wheel Width Range

2 - 20 inches (51 - 508 mm)

### Maximum Outside Tire Diameter

Up to 44 inches (1016 mm)

### Maximum Tire/Wheel Weight

150 pounds (68 Kg)

90 pounds (40 Kg) Saudi Arabia

### Mounting Shaft Diameter

40 mm

### Resolution (Round Off Mode)

0.25 ounce, position 1.40 degrees

### Resolution (Non-Round Off Mode)

0.01 ounce, position 1.40 degrees

### Balancing Display Increments

0.25 or 0.01 ounces

### Electrical Requirements

220V, 1 PH, 60 Hz, 20A

NEMA L6-20R

220V, 3 PH, 60 Hz, 20A

NEMA L15-20R

220V, 1PH, 60 Hz, 10A (Saudi Arabia)

240V, 1PH, 50 Hz, 10A (Australia)

(use grounding type plug)

### Footprint

Depth: 60 inches (1524 mm)

Width: 60 inches (1524 mm)

### Shipping Weight

680 pounds (308 Kg)

(with accessories)

## Features

- Automatic Data Entry for Offset and Diameter - Manual Entry Backup on all Parameters.
- Static-on-Screen™
- Direct Select™ Weight Placement Location
  - Dynamic (Standard): Clip-on Weights
  - Alloy: User Defined
  - Static
- Behind the Spoke Weight Placement
- Automatic Start When Hood is Lowered
- Single Spin Balancing - Dynamic and Static
- Easy-To-Read Position Indicators
- Hood Safety Interlock System
- Extended Mounting Faceplate for Deeper Wheels
- Removable Center Shaft for Closed Center Wheels
- Match Balance (Optimization)
- Operator Memory for Two Different Users
- User Friendly Weight and Position Calibration
- No Bolt-down Installation
- Solid State Motor Control

## Accessory Options

### Basic Accessory Kit 85009974

- Small Cone
- Medium Cone
- Large Cone
- Light Truck Cone
- Rim Width Calipers
- Wheel Weight Pliers
- Hubnut Handle
- Small Pressure Cup & Rubber Lip
- Cone Spring
- Scraper
- Cone Peg Brackets

## ★Balancing Your First Tire

### 1. Turn the machine OFF then ON (resets machine).

The machine wakes up using standard clip-on wheel weight locations (Clip 1 & Clip 2) and wheel dimensions.

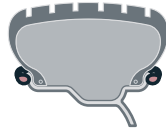

### 2. Mount a tire/wheel onto balancer that will use standard clip-on wheel weights.

Use the most appropriate mounting method.

### 3. Always remove any weights already attached to the wheel.

### 4. Enter A & D wheel dimensions using offset arm.

For Automatic Measurement — pull offset arm out to the wheel, hold it still at clip-on weight position against wheel flange, and wait for BEEP. Return arm to home position.

Clip-on Weight Location — viewed on a cut-away rim for clarification.



Figure 2 - Clip-On Weight Location

Note the value entry of A & D dimension.

### 5. Enter Width wheel dimension.

For Manual Entry — Use plastic calipers to measure wheel width. Press W key. Press Up or Down arrow to enter Width value (between 2.0 and 14.0 inches).

### 6. Lower Wheel Guard; wheel spins and unbalances are measured and displayed.

The corrective weight amount appears in the weight display window for inboard and outboard weight locations.

### 7. Raise hood after tire stops rotating.

**Note:** Wait for wheel to stop before raising the wheel guard.

### 8. Rotate wheel until Inboard weight position bar blinks.

**Note:** If an inboard corrective weight is not required then go to step 10.

### 9. Attach inboard corrective weight.

Attach specified weight amount at top-dead-center on inside flange of wheel (clip 1).

### 10. Rotate wheel until Outboard weight position bar blinks.

### 11. Attach outboard corrective weight.

Attach specified weight amount at top-dead-center on outside flange of wheel.

### 12. Lower the hood to respin the tire/wheel and check balance.

The weight readings should now be 0.00.

**Note:** Throughout this manual tire dimensions are referred to as A, W, and D, see figure 3.

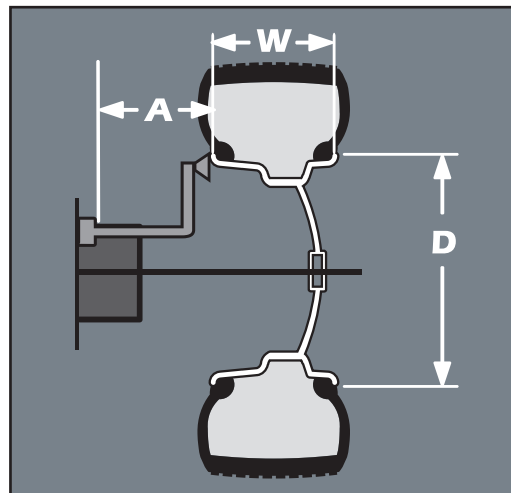

Figure 3 - A, W, and D Tire Dimensions



## Principle Operating Parts

### Know Your Unit

Compare this illustration with the unit before placing it into service. Maximum performance and safety will be obtained only when all persons using the unit are fully trained in its parts and operation. Each user should learn the function and location, of all controls.

Prevent accidents and injuries by ensuring the unit is properly installed, operated and maintained.

- A** - Control Panel
- B** - ON/OFF Switch (back of machine)
- C** - Plug (back of machine)
- D** - Weight Tray with Pockets for Weights
- E** - Offset Arm, Measures A & D of Tire/Wheel (Shown In Home Position)
- G** - 40 mm Shaft
- H** - Hood Guard



**Note:** Throughout this manual, wheel weights are referred to as Clip-on or Tape-A-Weight®. Figure 4 shows an example of each weight.



**Clip-on Weight**

**Tape-A-Weight®**

Figure 4 - Corrective Weight Examples. For Best Results, use BADA® Brand Wheel Weights.

### Power Switch

The ON/OFF switch location (figure 5) is at the back of the balancer; below the weight tray.



Figure 5 - On/Off Switch

### Using The Offset Arm

When not in use or when prompted by the balancer instructions, store the offset arm in the home position as shown in figure 6.

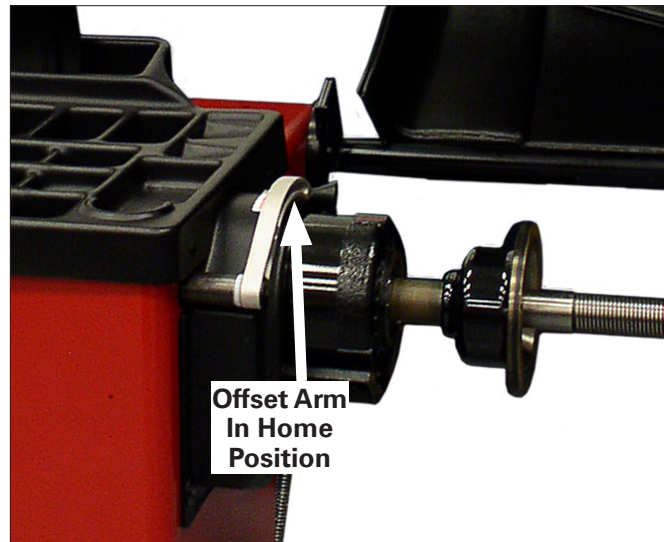

Figure 6 - Location of Offset Arm (Stored In Home Position)

When prompted by balancer instructions, use the offset arm (figure 6) to enter A & D measurements automatically. Pull the arm out and up against the wheel flange; hold it still at the clip-on weight location (figure 7), against the wheel flange, and wait for the BEEP.



Figure 7- Automatic A & D Measurement At Clip-on Weight Location

Be sure to place the offset arm on the wheel flange at the clip-on weight location as shown, figure 8.



Figure 8 - Clip-on Weight Location Viewed on a Cut-Away Rim for Clarification

**Note:** Use the offset arm to automatically measure the A & D dimension for all balancing modes.

**Note:** Refer to page 13 to measure the A dimension manually using the offset arm.

**Note:** The T2 Tape Direct™ Select Weight position is the only mode that requires the A2 & D2 dimension measurements.

If the T2 Tape (hidden Tape-A-Weight®) location is selected, use the offset arm to enter A2 & D2 measurements, automatically. After the A & D measurement is entered, move the arm from the clip-on weight location to the inner area of the wheel; up against the rim at the Outboard weight placement location (see figures 9 & 10). Wait for the BEEP.



Figure 9 - Hidden Weight Location Viewed on a Cut-Away Rim for Clarification

**Important:** The A2 measurement must be at least 2 inches greater than the A1 measurement.

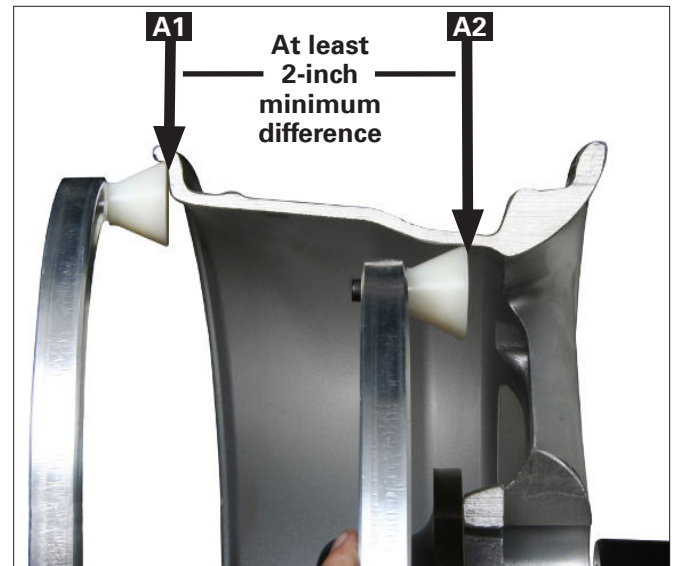

Figure 10 - T2 Tape (Hidden Tape-A-Weight®) Keep At Least 2-inches Between A1 and A2 Measurement

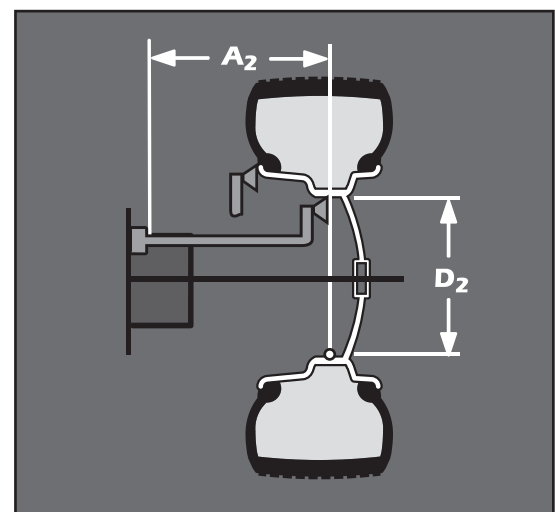

Figure 11 - T2 Tape (Hidden Tape-A-Weight®) Data Entry Diagram

## Control Panel Layout

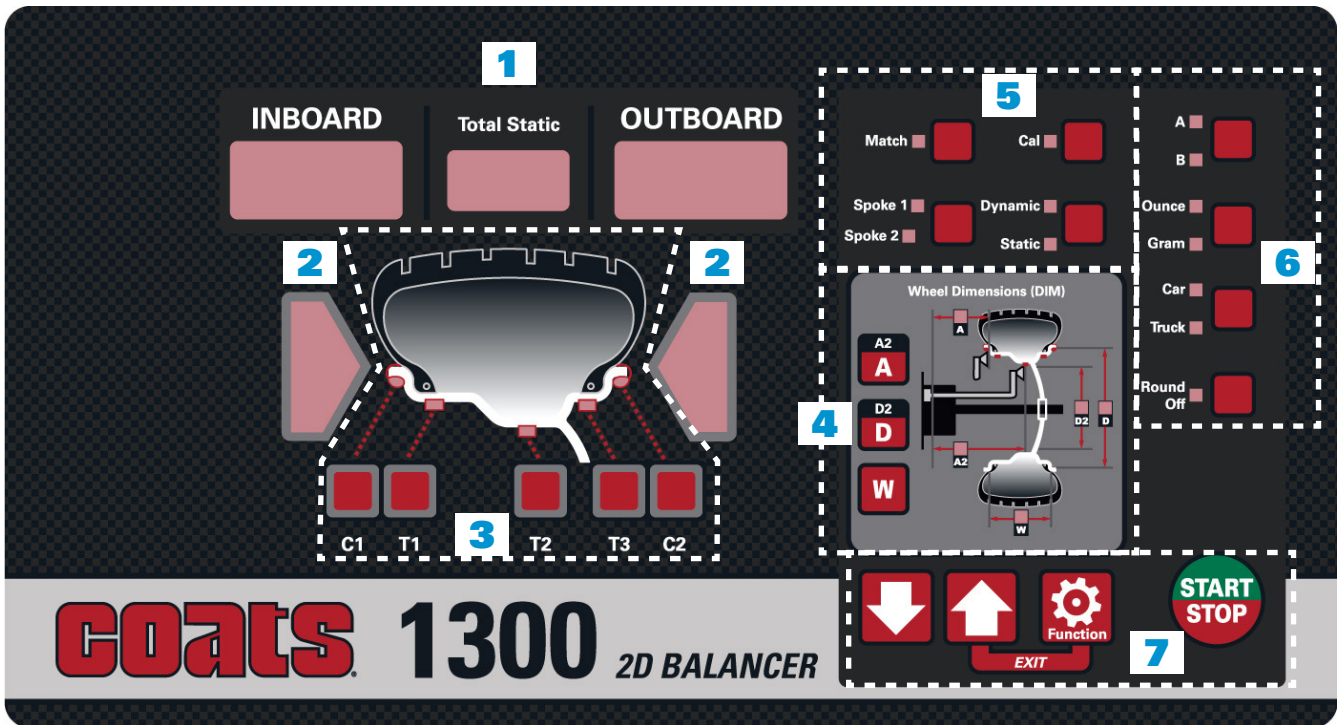

Figure 12 - Control Panel Feature Reference

### Control Panel Function and Review

#### 1 Weight Display Windows

Two weight display windows, one Inboard and one Outboard, are positioned above the Wheel Cross-section Diagram. After a wheel measurement cycle, the balancer calculates the corrective weight amount and indicates it in the appropriate display window. All weight readings are shown in Ounces or Grams. Also displays A, W, and D values, functions, and instructions for the operator. Error messages will also be shown in this display.



The Total Static window indicates the value of the total static unbalance. See MATCH BALANCE (Optimization) on page 16 for further details.

#### 2 Weight Position Bars



Located on either side of the wheel cross-section diagram are the weight position bars, one Inboard and one Outboard. After a measurement cycle, rotate wheel until the center weight position bar blinks, indicating the correct weight placement position is at top-dead-center.











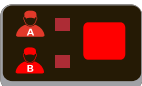

Key Group	If you press/select ...	Then indicator illuminates/displays...
-----------	-------------------------	--

#### 3 Direct Select™ Weight Keys & Wheel Cross-section Diagram

	Clip 1, or Tape 1	the activated Inboard weight location on the wheel cross-section diagram.
	T2 Tape, T3 Tape or Clip 2	the activated Outboard weight location on the wheel cross-section diagram.

#### 4 Wheel Dimensions (DIM) Keys & Measurement Diagram

	A, D, or W	the activated wheel measurement location. The default is Clip 1 and Clip 2. Enter wheel data manually using either the Up or Down arrow key.
	A2+Function or D2+Function	

Key Group	If you press/select ...	Then indicator illuminates/displays...
<b>5 Balance Mode Keys</b>		
	Match	that Match Balance (Optimization) mode is activated.
	Spoke	that Behind Spoke mode is activated Toggle to activate / select location 1 or location 2 for adhesive weights.
	Calibration	that Machine Calibration mode is activated.
	Function+Calibration	that Arm Calibration mode is activated.
	Dynamic or Static	the Balance mode that is activated. Scroll to select Dynamic (default), Dynamic/Total Static or Static.
<b>6 Balance Option Keys</b>		
	A or B	the Operator Memory option that is activated. Toggle between two operator memories A (default) or B.
	Ounce or Gram	the weight measurement option that is activated. Toggle to select either Ounce (default) or Gram.
	Car or Light Truck	the weight increment option that is activated. Toggle to select either 0.25-ounce passenger car (default) or 0.50-ounce RV-Lt Truck (heavy wheels).
	Round Off	the weight increment option 0.25-ounce (default) is activated. Toggle off to select 0.01-ounce (fine).
<b>7 Navigation Keys</b>		
	Down Arrow or Up Arrow	the data entry values. Scroll to select desired value.
	Function	the activated function. Usually used in combination with another key.
	EXIT	that the function or error is deactivated.
	START / STOP	that measurement cycle is either begun (hood lowered) or is halted.

## Mounting Wheel On Balancer Shaft



Avoid back injury, seek assistance when lifting heavy tire/rim assemblies onto the balancer shaft.



Failure to tighten the hub nut properly may result in the wheel dismounting, causing personal injury and property damage.

Select the most appropriate mounting method for the wheel you are balancing. Using the proper method ensures secure mounting and safe balancer operation, and prevents damage to the wheel.

On most wheels, the inner side of the wheel hub usually has the most uniform surface for wheel balancing. Always center the wheel by the most uniform shaped side of the hub to achieve the most accurate balance.

Regardless of mounting type, on standard units, always make sure that the wheel is forced firmly against the shaft faceplate and that the hub nut engages the threaded shaft for at least four complete turns. To assist in centering the wheel properly, rotate the wheel and the shaft while tightening the hub nut.

## Standard Back Cone Mounting

Most original equipment and steel wheels can be mounted properly using this method. The wheel is centered on a cone from the inner side of the hub.

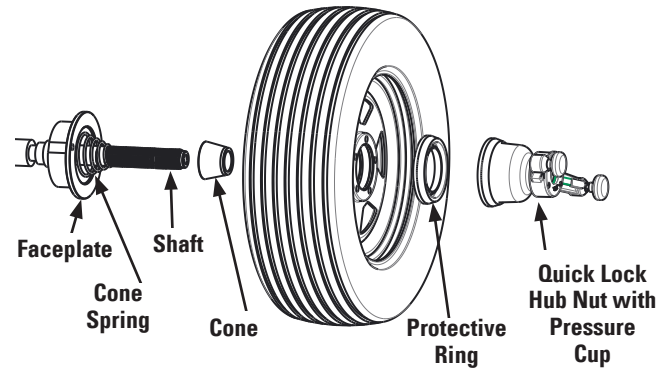

Figure 13 - Standard Back Cone Mounting

1. Place the cone spring onto the balancer shaft with the large end towards the faceplate.
2. Select the cone that best fits the center hole in the wheel. Slide the cone onto the shaft with the large end towards the cone spring.
3. Lift wheel onto the shaft and center it on the cone.
4. Attach pressure cup to hub nut. Install the hub nut assembly onto the shaft and tighten it securely against the wheel. The wheel must be forced firmly against the faceplate. The hub nut must engage the threads for at least four full turns

**Note:** Use a nylon spacer (protective ring) to protect custom wheel finishes.

**Note:** If the hub nut will not tighten completely, use the front cone mounting method.

## Optional Front Cone/Collet Mounting

A wheel should be centered by the outer side of the hub only when the inner surface will not provide an accurate surface to center on.

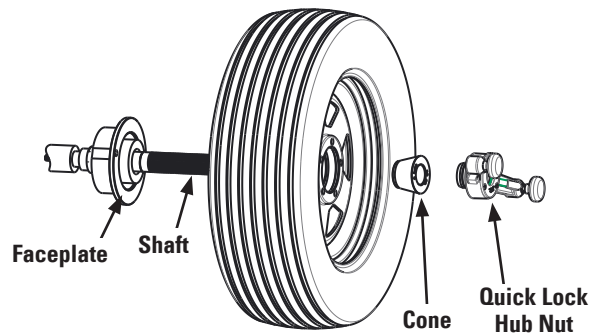

Figure 14 - Front Cone Mounting

- 1.** Select the cone that best fits the center hole in the wheel.
- 2.** Lift the wheel onto the balancer shaft and slide it back against the faceplate.
- 3.** Slide the cone onto the shaft and into the center hole of the wheel. You will need to lift the tire to seat the cone in the center hole.
- 4.** Install the hub nut (without pressure cup) onto the shaft. Tighten it securely against the cone. The hub nut must engage the threads for at least four full turns.

**Note:** If the hub nut will not tighten completely because of a lack of threads, use an additional cone as a spacer between the mounting cone and the hub nut. The wheel must be forced firmly against the faceplate.

**Note:** Do Not front cone chrome or clad wheels.

## Alternate Mounting

If the wheel has a protruding outer hub which will not permit the use of the pressure cup, or the cup will not permit the hub nut to engage at least four turns of the shaft, this alternate method should be used.

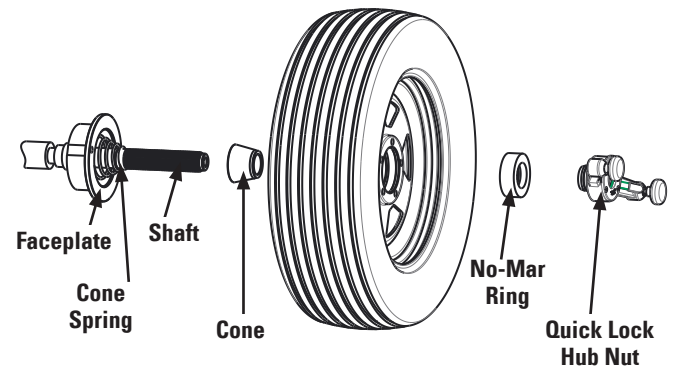

Figure 15 - Alternate Mounting

- 1.** Place the cone spring onto the balancer shaft with the large end towards the faceplate.
- 2.** Select the cone that best fits the center hole in the wheel. Slide the cone onto the shaft with the large end towards the faceplate.
- 3.** Lift wheel onto the shaft and center it on the cone.
- 4.** Use the small nylon spacer (no-mar ring) or a centering cone to press against the outer wheel hub.
- 5.** Install the hub nut (without the pressure cup) onto the shaft. Tighten securely.

## Direct Select™ Weight Location

Before spinning the wheel, use direct select to indicate weight placement locations on the wheel as follows:

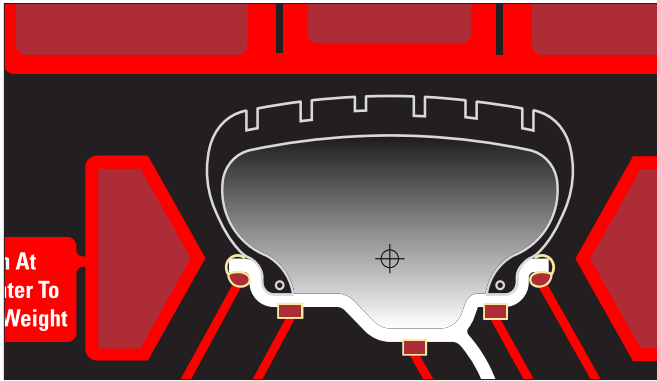

Figure 16 - Direct Select™ Weight Keys & Wheel Cross-section Diagram

**Note:** When the machine is turned ON, the balancer defaults to a 2-plane dynamic mode using standard clip-on wheel weight locations (Clip 1 and Clip 2) and wheel dimensions.

**Clip 1 (default)** - select this location to place a standard clip weight on the Inboard rim flange.

**T1 Tape** - select this location to place an adhesive weight on the Inboard side of the wheel that is the horizontal plane at the outer edge.

**T2 Tape** - select this location to place an adhesive (hidden) weight on the Outboard side of the wheel that is the horizontal plane in the inner area.

**T3 Tape** - select this location to place an adhesive weight on the Outboard side of the wheel that is the horizontal plane at the outer edge.

**Clip 2 (default)** - select this location to place a standard clip weight on the Outboard rim flange.

## Setting Wheel Dimensions (DIM)

Before a wheel can be balanced, wheel dimensions must be entered into the computer.

### Definition of Dimensions (DIM)

#### A = Offset

The distance measured from the balancer ("0" on offset arm) to inner plane of the rim (inner weight location).

#### W = Width

The width of the wheel at the rim flanges, measured with the calipers as shown in figure 19.

**Note:** Only use calipers provided by the wheel balancer manufacturer because others may not be the same.

#### D = Diameter

The diameter of the wheel as indicated on the tire.

**Note:** A thick flange, on some aluminum wheels, can effect the measured diameter. For example, a 16-inch rim can have a measured diameter of 15.5-inches.

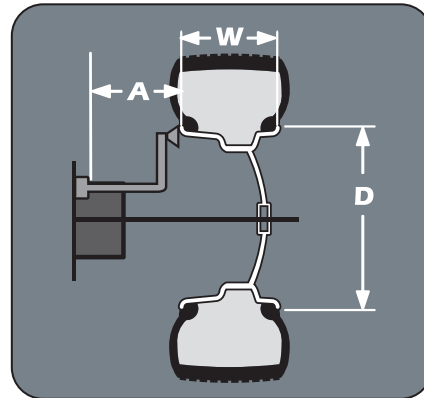

Figure 17 - W, D, and A Tire Dimensions

#### A2 = Offset

The distance measured from the balancer ("0" on offset arm) to outer plane of the rim (outer weight location). Used only for adhesive weight location.

#### D2 = Diameter

The diameter as measured at the A2 weight location. Used only for adhesive weight location.

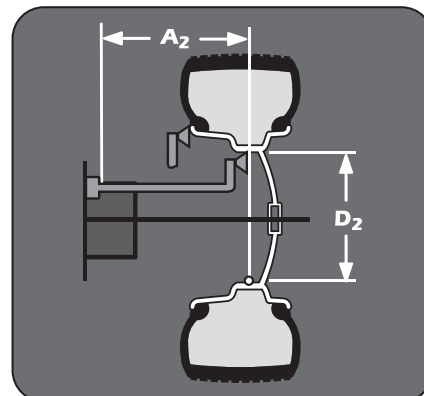

Figure 18 - A2 and D2 Tire Dimensions



## Basic Wheel Data Entry

**1.** Direct Select™ an Inboard weight location (Clip 1, or T1 Tape) and an Outboard weight location (T2 Tape, T3 Tape or Clip 2).

**2.** Position offset arm at clip weight location; wait for BEEP (A & D enters automatically).

**If the T2 Tape location is selected**, then move the offset arm from the clip weight location to the inner area of the wheel; up against the rim at the outboard weight placement location; wait for BEEP (A2 & D2 enters automatically).

**3.** Return offset arm to the home position.

**Note:** Steps **4 and 5** are **Not Necessary** when using **T2** or **STATIC** modes.

**4.** Use caliper and measurement rim width.

**5.** Use UP / DOWN arrows to adjust the W (Width DIM) to match measured caliper width of mounted rim.

**6.** Lower hood and spin wheel.

## Entering Wheel Dimensions Manually

Information entered into the balancer software for A, W, and D can be changed anytime during a balancing procedure by entering the measurements manually. The balancer will recalculate weights and positions based on the new measurements.

### Wheel Offset - A

**1.** Press the A (wheel offset) key.

**2.** Position offset arm at weight location on wheel and read the number on the offset arm gauge, at the cabinet (this is the correct offset A DIM).

**3.** Use UP / DOWN arrow to adjust the measurement.

### Wheel Diameter - D

**1.** Press the D (wheel diameter) key.

**2.** Inspect mounted tire sidewall to determine the exact diameter this is printed on the tire.

**3.** Use the UP / DOWN arrow to adjust the D (Diameter DIM) to match the tire sidewall size.

**Note:** Auto entry is the preferred method for entering A2 and D2. However, to manually enter A2, press Function+A and hold. And to enter D2, press Function+D and hold.

### Wheel Width - W

**Note:** The following step are **Not Necessary** when using **T2** or **STATIC** modes.



**1.** Press the W (wheel width) key.

**2.** Use the plastic calipers provided with the wheel balancer to measure the wheel width.

*Figure 19 - Caliper Placement On Wheel*

**3.** Use UP / DOWN arrows to adjust the W (Width DIM) to match measured caliper width of mounted rim.

## Balancing A Wheel

A variety of wheel configurations can be balanced using this wheel balancer. Read through this section, it will help in determining which balancing mode and options are best suited for certain wheel assemblies.

**Remember:** As with any balancing procedure, first remove any weights attached to the wheel, inspect the tire and wheel, and use the most appropriate balancer mounting method before beginning.

### Dynamic Balancing

Choose a dynamic balance to balance a wheel using two planes for correction. Select the weight option that best fits the available weight locations on the rim.

**Clip-on Weights** - The standard default; used for most passenger tire/wheel assemblies using the most common location for corrective weights. Clip-on weights are placed on the inner (inboard) and outer (outboard) rim flanges.

**ALUS (Aluminum Wheels)** - To balance aluminium wheels you usually use a self-adhesive weight location that is positioned differently from the clip-on weight position(s) used in standard balancing. Be sure to use the appropriate wheel data entry method since the balancer calculates out of balance values based on the wheel dimension measurements (DIM) entered for the tire/wheel assembly.

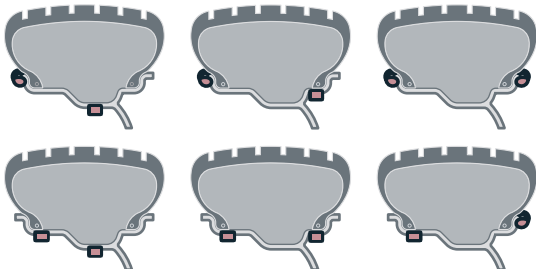

Figure 20 - Dynamic Balance Weight Locations

**Note:** When the machine is switched on, a standard dynamic balance using clip-on weight locations is the default setting.

### Static Balancing

Choose a static balance to balance a wheel using one plane for correction. Place the single corrective weight at top-dead-center (12 o'clock) on either flange, at the center of the rim channel, placed inward either side, or split on either sides.

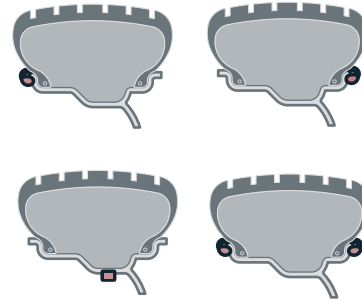

Figure 21 - Static Balance Weight Locations

**Note:** When in static mode, you only need to input the DIAMETER wheel measurement.

**Important:** If you decide to use the rim channel for corrective weight placement, remember you may need to adjust the DIAMETER measurement input. Typically you would make it 2 or 3 inches less than the actual tire/wheel diameter.

## Behind Spoke Mode

"Splitting" the T2 Tape corrective weight amount is used to hide the adhesive weight behind two rim spokes.

- 1.** When the unbalance is displayed, rotate wheel until Inboard center bar blinks. Attach Inboard corrective weight at top-dead-center.
- 2.** Next, rotate wheel until the outboard center bar blinks.
- 3.** Select the Behind Spoke mode option. "SP1" will display in the static display window.
- 4.** Rotate the wheel toward front until the first spoke is at top-dead-center.; press Spoke and 1 illuminates. "SP2" will display in the static display window.
- 5.** Rotate the wheel toward rear until the second spoke is at top-dead-center; press Spoke and 2 illuminates. Now at the Spoke 2 location, the Outboard center bar stops blinking.

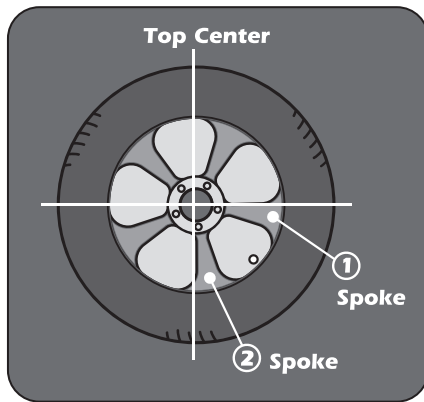

Figure 22 - Spoke 1 and Spoke 2 Locations On Either Side Of Original Outboard Weight Location

- 6.** Attach the Spoke 2 Outboard corrective weight at top-dead-center behind spoke 2.
- 7.** Next, rotate the wheel toward the Spoke 1 location until the outboard center bar is blinking.
- 8.** Attach the Spoke 1 Outboard corrective weight at top-dead-center behind spoke 1.
- 9.** Respin tire/wheel to check balance.

## Corrective Weight Placement

After the wheel spins and out of balances are measured and displayed, the corrective weight amount appears on the weight display window for Inboard and Outboard weight locations. Bars appear on either side of the wheel cross-section diagram to aid in positioning the wheel for corrective weight at the application point.

After a measurement cycle, rotate wheel until the center weight position bar blinks, indicating the correct weight placement position is at top-dead-center. If the out-of-balance is less than the chosen threshold value, 000 appears instead of an out-of-balance value to indicate that, on that particular side, the wheel is in tolerance.

## Match Balance (Optimization)



**Match Balance involves the loosening of tire beads and the inflation of a tire. Training is necessary in tire changer operation and understanding the dangers involved during bead seating and tire inflation before attempting this stage of the Match Balance procedure. Read the operators manual supplied with the tire changer and consult a supervisor.**

Use the Match Balance (Tire/Rim Weight Optimization) program to determine the best mating of tire and rim that will result in the least amount of total unbalance of the assembly. It requires two spins and two rotations of the tire on the rim. Match Balance may be needed when:

- The customer complains of ride problems.
- The balancer calculates a high out of balance.
- The balancer calls for Total Static weights in excess of 3 ounces (85 grams) on passenger car tires.

**Important:** A high unbalance may indicate the improper mounting of the assembly on the balancer, or a rim that is out of round or misformed, or a tire with a bubble or other problem. If the unbalance is excessive, it may be prudent to replace the rim, the tire, or both. If either is replaced, do not continue with Match Balance. Balance the new tire and rim and evaluate the readings.

## Match Balance Mode

If you choose to use Match Balance to correct for a condition, such as a large static unbalance, then follow the machine prompts and instructions for the MATCH BALANCE procedure as outlined in the following steps.

**Note:** Use this procedure only after the wheel has spun and the corrective weight amount is displayed.

**Note:** Use the Total Static display option. See Balance Options, page 14, for further details.

**1.** Press Match to select the Match Balance mode. A "1" will appear in the Outboard weight display.

**2.** Raise the hood and rotate the wheel until the valve stem is at top-dead-center. Mark the tire sidewall at the valve stem.

**3.** Press Function on the control panel; a "2" will appear in the Outboard weight display.

**4.** Remove the wheel assembly from the balancer.

**5.** Using a tire changer, rotate the tire 180 degrees on the rim.

**6.** Remount wheel assembly on the balancer. Press Function on the control panel; a "3" will appear in the Outboard weight display.

**7.** Lower the hood. The wheel spins; a "4" will appear in the Outboard weight display.

**8.** When the wheel stops spinning, raise the hood and rotate the wheel until the valve stem is at top-dead-center.

**9.** Press Function on the control panel. Weight amounts appear on the control panel.

The amount in the Inboard weight display is the weight imbalance for the rim. The amount in the Outboard weight display is the weight imbalance for the tire. Use these weight amounts to determine the suitability of the rim or tire.

**Note:** If either the rim or the tire weight amount is close to zero or zero then using Match Balance will not affect the total unbalance of the assembly.

**10.** Rotate the wheel until the Outboard weight position bar flashes. Mark the tire at top-dead-center.

**11.** Remove wheel assembly from balancer.

**12.** Using a tire changer, rotate the tire until the mark is aligned with the valve stem.

**13.** Remount the wheel assembly on the balancer.

**14.** Press Function to exit Match Balance. Select a balancing mode and balance the wheel assembly.

## Calibration Program

**Important:** Be sure to use the correct calibration weight amount: a 4-ounce calibration weight with the ounce option or a 100-gram calibration weight with the gram option activated. Be sure to deactivate the Round Off option.

### Machine Calibration

For machine calibration, proceed as follows:

**1.** Mount a 14, 15, or 16-inch steel tire/wheel assembly on the balancer. A balanced tire/wheel is required.

**Note:** Position wheel so that no weights are on either flange at the top-dead-center location. Turn the machine OFF then ON.

**2.** Press and hold Calibration key for three (3) seconds to select Machine Calibration mode.

**3.** Press "D" key to enter the D (diameter) dimension. Press the Up and/or Down arrow key to adjust numbers. A valid data entry is either "14", "15", or "16".

**4.** Press the Function key.

**5.** Lower the hood and press the START key to begin the measurement cycle.

**6.** After the tire/wheel stops spinning, raise the hood.

**7.** Rotate wheel until the Outboard center bar blinks. Attach calibration weight (either 4-ounce or 100 gram) to the outboard flange at top-dead-center.



Figure 24 - Calibration Weight On Outboard Flange At Top-Dead-Center

**8.** Lower the hood and press the START key to begin the measurement cycle.

**9.** After the tire/wheel stops spinning, raise the hood.

**10.** Rotate wheel until the Inboard center bar blinks. Move and attach the 100-gram calibration weight to the inside flange at top-dead-center.

**Important:** It is critical that the inner weight be placed accurately to achieve proper calibration. If the calibration weight is not moved from the outside flange directly across to the inside flange, an inner weight placement error will occur and the calibration will be



"failed".

Figure 25 - Calibration Weight On Inboard Flange At Top-Dead-Center

**11.** Lower the hood and press the START key to begin the measurement cycle.

**12.** After the tire/wheel stops spinning, machine displays "100, END CAL".. Machine Calibration is complete.

**13.** Press FUNCTION to exit.

## Arm Calibration

**Important:** Always perform the Arm Calibration immediately after Machine Calibration. The balancer software will not permit it otherwise. During Machine Calibration, the balancer software calculates both the A (offset) and W (width) dimensions. The Arm Calibration gives the balancer software a reference point to the edge of the faceplate and home position. When the user enters the A dimension from the arm rod, it calculates the difference from the Machine Calibration A and uses that as a factor for the manual A entry. Arm Calibration also gives the D dimension a reference point from home position.

**1.** Complete the Machine Calibration procedure (see page 17).

**2.** Press and hold the Function key and Calibration key for three (3) seconds to select the Arm Calibration mode.

**3.** Bring the tip edge of the arm precisely to the outer edge of the faceplate and hold it there while pressing the Function key. If necessary to reach the faceplate accurately, loosen the calibration wheel temporarily.

**4.** With the arm still at the edge of the faceplate, press A key and use UP / DOWN arrow to adjust A dimension value as shown on arm gauge. Display will

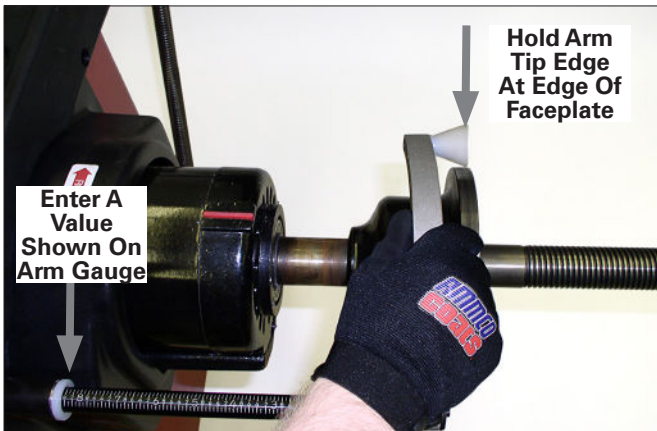

show at static position of LED. Press Function key.

*Figure 26 - While holding Arm At Faceplate Edge, Enter A*

**5.** Move the arm to its home position and press the Function key.

**6.** Move the arm to the clip-on weight location on the rim flange and hold it there; press D key and use UP / DOWN arrows to adjust the D dimension value. Display will show at static position of LED. Press Function key.

**7.** While still holding the arm at the clip-on weight position on the wheel, press A key and use UP / DOWN arrows to adjust the A dimension value as read off the arm gauge. Press Function key.

**8.** Return arm to home position.

**9.** When machine displays "END", the Arm Calibration is complete. Press FUNCTION to exit.

**Important:** To redo the Arm Calibration procedure, press and hold FUNCTION and press "Clip 1" for 3 seconds to enter CDE mode, then press "T1 Tape" then press "W" to bypass the Machine Calibration requirement. Always use the same wheel assembly that was used during the Machine Calibration or else the calibration will not be correct.

## Maintenance Instructions



**Use caution, this is an electrical device. Exposing the balancer to water, either by hose or bucket, or by exposure to rain or snow, may cause risk of shock or electrocution to operator or bystanders. Place, store, and operate the balancer only in a dry, sheltered location.**



**Do not hose down with water or bucket wash the balancer. Extensive damage to the balancer will result. Sensitive electronic components, wiring harnesses, and other devices housed in the balancer are not intended to be exposed to water.**

The balancer requires only minor maintenance to keep the unit operating properly.

**1.** Keep the display clean and clear. Use a damp cloth. Do not use cleaners or solvents which leave oily or filmy residues behind.

**2.** Keep the adapters, cones, faceplate, threaded shaft, pressure cup, and hub nut clean. Grease and dirt buildup will cause inaccurate balancing and premature wear. Clean these items at least once a day with a vaporizing solvent.

**3.** Clean weight tray and any accessory posts, pegs, or storage shelves with a vaporizing solvent. Weights stored in a dirty tray may pick up grease and dirt which may keep them from securely attaching to the wheel.

**4.** Keep the area around and under the balancer clear. Remove any tools or other items that are leaning against the balancer. Remove any items that may cause the balancer to not sit level. Be particularly cautious of new or used wheel weights on the floor, as they may cause personal injury due to falls.

**5.** Use only COATS® accessories. Accessories from other manufacturers may not fit or function properly, and may damage the balancer.

**Important:** Always be sure to remove the wheel assembly from the pneumatic shaft before disconnecting the air supply from the machine.

## Diagnostic Procedures

### After Balance Vibration Problems

If vibration is still present after balancing the wheels and driving the vehicle on smooth pavement, remove the wheels and recheck the balance. If a wheel is out of balance the cause maybe:

- Wheel was not mounted/centered correctly on the balancer.
- A weight has come off the wheel (possibly the wrong clip style). Remove the other weights from the wheel and rebalance.
- Foreign material inside the tire. Remove the tire from the wheel, remove the foreign material, and remount. Remove wheel weights and rebalance the wheel.
- Stones or other foreign objects caught in the tire tread or rim. Remove the objects. Check and rebalance if needed.

If the balancer still indicates the wheels are balanced to within 0.05 ounces (1.42 grams) on both Inboard and Outboard displays, the problem is not in the balance of the wheels. Check the following possible sources of vibration:

- Tire pressure. Bring all tires up to the recommended PSI.
- Radial or lateral runout in the tire or wheel. Replace the damaged part.
- Unbalance in wheel covers or trim rings. Remove the wheel covers or trim rings and test drive. If the vibration is gone, remove the shaft and use an appropriate adapter to mount the wheel to the balancer. Balance the wheel with the wheel cover or trim ring attached to the wheel.
- Incorrectly mounted tire and wheel. Remount correctly.
- Damaged wheel bolt holes. Replace wheel.
- Worn universal joints. Replace as required.
- Drive shaft unbalance or damaged. Balance, repair, or replace.
- Unbalance in brake rotor(s) or drum(s).
- Suspension out of alignment. Align the vehicle and replace any damaged or worn parts.

## Troubleshooting

A COATS® Service Technician may ask for information to help diagnose service concerns (please contact COATS directly at 1-800-688-9240 for the Certified Service Partner nearest you). Conveying this information to your service technician prior to servicing can help to expedite service to your equipment. Although much of the diagnostic information aids your COATS Service Technician, several remedies for balancer misfunctions are available to the operator.

**Error Messages** - One of the following error messages, shown in the display windows, may appear indicating a problem with the balancer.

**Note:** Always exit the error message by pressing the Up arrow+Function key; then repeat the procedure to see if the error is eliminated.

<b>Error</b>	<b>Description</b>
<b>E1</b>	Spin up is too slow - Verify power supply to balancer and motor connection
<b>E2</b>	Spin up time too long - Check Wheel DIA and power supply - press STOP - EXIT
<b>E3</b>	No rotation signal - Check motor & encoder function & wiring -press STOP - EXIT
<b>E4</b>	Wheel rotation direction is reversed - Disconnect power and correct wiring
<b>E5</b>	Stop time too long - Verify power supply and motor connection - press STOP - EXIT
<b>E6</b>	Encoder is not connected or has failed - Disconnect power supply and repair
<b>E9</b>	Wheel coast speed is too slow
<b>E11</b>	User cancelled the operation
<b>E20</b>	Arm scale is out of range
<b>E24</b>	Lower hood to spin
<b>E25</b>	Loose hub nut. Tighten hub nut and respin
<b>E26</b>	CAL ERROR
<b>Err Hod</b>	Hood switch is not closed when machine cycle is started - Lower hood to spin - Verify hood switch
<b>Err Hub</b>	No load condition detected - Verify wheel mounted properly on the shaft - Check repeatability
<b>Err Ad</b>	No dimension input



<b>Error</b>	<b>Description</b>
<b>100, N01, CAL</b>	Exceeded 5 degree range between placement of calibration weight from outside flange to inside flange.
<b>100, N02, CAL</b>	Calibration wheel is more than 1-ounce out of balance. Calibration is rejected.
<b>100, N03, CAL</b>	Calibration wheel is more than 0.25-ounce but less than 1-ounce out of balance. Calibration is stored, but with warning.

**Overload Protection** - The balancer's motor is overload protected per UL requirements. After 4 to 5 minutes the machine automatically resets itself; activating the fan motor. If this happens, notify your Certified Service Partner immediately.

**Important:** Allow the fan to cool the motor for at least 30 minutes before using the balancer so the overload protection is not tripped again.

## Glossary

**ALUS** -Alloy wheel mode that typically requires the use of one or two adhesive weights for correction.

**Balancer Flange** – Disk that mates with the disk of the wheel mounted to the balancer. The flange also serves to keep the wheel perfectly perpendicular to its axis of rotation.

**Balancing Cycle** – Sequence of operations performed by the user and the machine, beginning from the start of the wheel spin to the time that the wheel is braked to a standstill after the out of balance signals are acquired and the relative values calculated.

**Centering** – Procedure for positioning the wheel on the spindle shaft with the aim of ensuring that the rotational axis of the wheel is aligned with the center of the shaft.

**Centering Flange (accessory)** – Device serving to support and center the wheel. Also keeps the wheel perfectly perpendicular to its axis of rotation. The centering flange is mounted to the balancer shaft by means of its center hole.

**Cone** – Conical components with center hole. When inserted on the spin shaft, serves to center wheels with centre holes whose diameter is between maximum and minimum values.

**Dynamic Balancing** – Operation in which out of balance is corrected by the application of two weights, one on each side of the wheel.

**Self-calibration** – A procedure whereby suitable correction coefficients are calculated by starting from known operating conditions. Self-calibration improves the measurement precision of the machine by correcting, within limits, calculation errors that may arise due to alteration of the machine's characteristic over the course of time.

**Spin** – Procedure starting from the action that causes the wheel to rotate and the successive free rotation of the wheel.

**Quick Nut** – Device for clamping the wheel to the balancer. The hubnut features elements for engaging to the threaded hub and lateral pins that are used to tighten it.

**Static Balancing** – In static balancing only the static component of out of balance is corrected. This is achieved by fitting a single weight, usually at the center of the rim channel. The accuracy of this system increases as the width of the wheel decreases.

**Threaded Hub** – Threaded part of the shaft that is engaged with the hubnut to clamp the wheel. This component is supplied disassembled from the machine.

**Out of balance** – Non-uniform distribution of the wheel mass that results in the generation of centrifugal force during rotation.





# COATS®

## Wheel Balancer Models 1300 2D, 1400 2D, 1500 3D & 1600 3D



Model 1300



Model 1400



Model 1500



Model 1600

### *Parts Identification*

READ these instructions before placing unit in service. KEEP these and other materials delivered with the unit in a binder near the machine for ease of reference by supervisors and operators.

**HENNESSY**  
INDUSTRIES

1601 J. P. Hennessy Drive, LaVergne, TN USA 37086 615/641-7533 800/688/6359 www.coatsgarage.com  
HENNESSY INDUSTRIES LLC. Manufacturer of COATS®, AMMCO® and BADA® Automotive Service Equipment and Tools.

Manual Part No.: 85610676 12  
Revision: 2/20

## **Parts Identification**

The following pages include parts breakdowns with exploded view illustrations to help with ordering replacement or spare kits. Assemblies are noted where it is recommended that individual parts not be ordered separately. Note that the parts view illustrations are for multiple models and not all parts shown are on all models. Every effort is made to supply accurate exploded views, however, due to interim changes in manufacturing operations, some units may not be exactly as illustrated.

### **Table of Contents**

<b>Label Locations.....</b>	<b>3</b>
<b>Wheel Guard Assembly.....</b>	<b>4</b>
<b>Wheel Guard Hood Damper (1600 only) .....</b>	<b>5</b>
<b>Chassis Assembly .....</b>	<b>6</b>
<b>Distance Gauge Assembly .....</b>	<b>7</b>
<b>Motor Assembly .....</b>	<b>8 - 9</b>
<b>Motor Shroud w/Hood LED Bar &amp; Switch.....</b>	<b>9</b>
<b>1300/1400/1500/1600 Monitor Assemblies .</b>	<b>10 - 11</b>
<b>1300/1400 Non-Inverter Model .....</b>	<b>12 - 13</b>
<b>1500/1600 Inverter Models.....</b>	<b>14 - 15</b>

# Label Locations

Part Number	Description
8113927	Caution / Warning
8120446	Motor Rotation
85010088	MET Lab Compliance
85608653	Patent Notice
85608779	Electric Shock
85610662	Main, 1400/1500/1600
85610679	Warning
85610721	Nameplate-1600
85610729	Nameplate-1500
85610730	Nameplate-1400
85610932	Nameplate-1300
85610746	Laser Hazard
85610747	Explanatory
85610749	Certification
85611015	Pedal Ops (1600 Only - if equipped)
85611259	Reverse Pedal (1600 Only - if equipped)

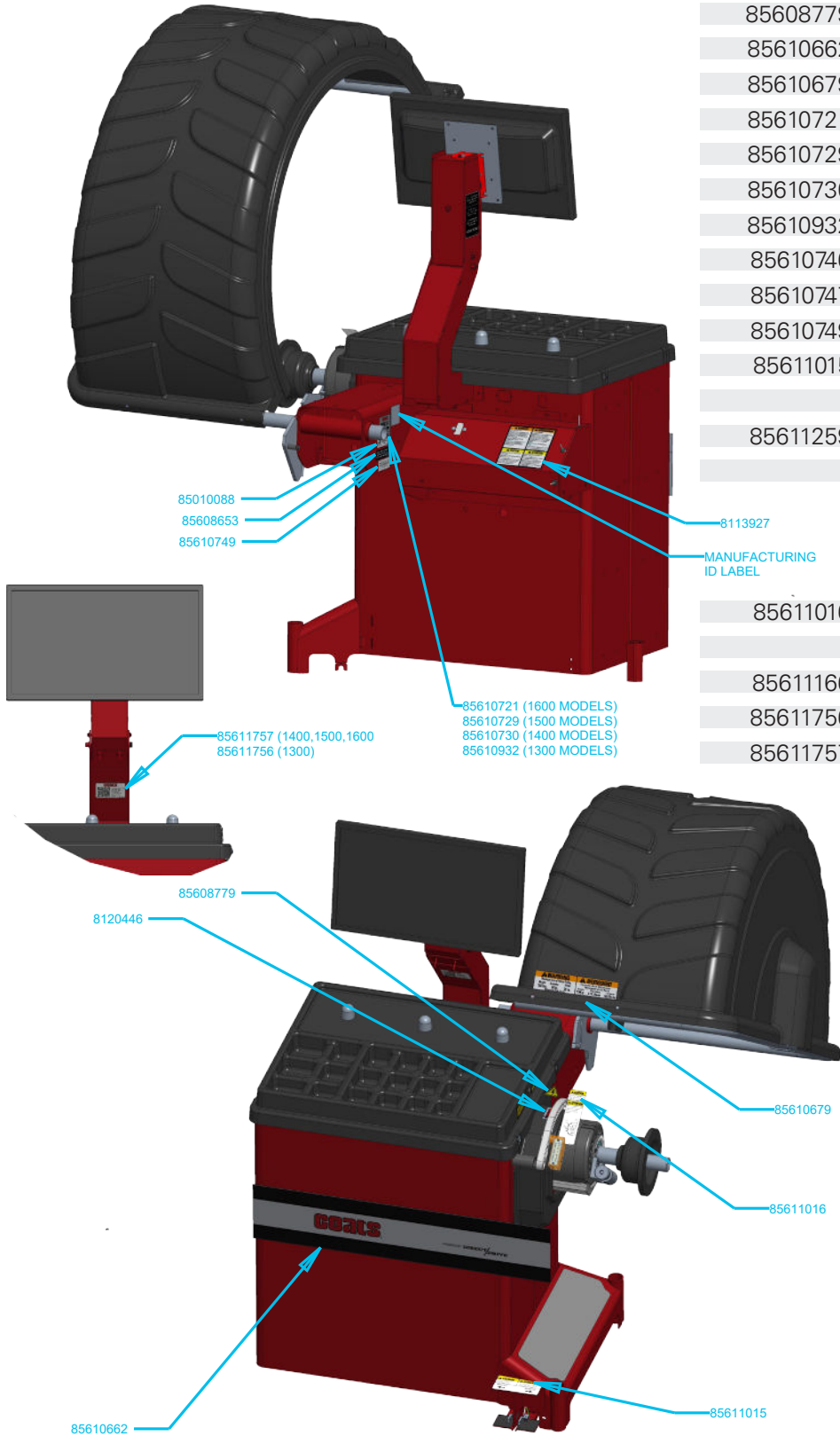

85611016	Caution, Pinch Point (1600 Only - if equipped)
85611166	Clean, Screen
85611756	1300 QR Code
85611757	1400, 1500, 1600 QR Code

# Wheel Guard Assembly

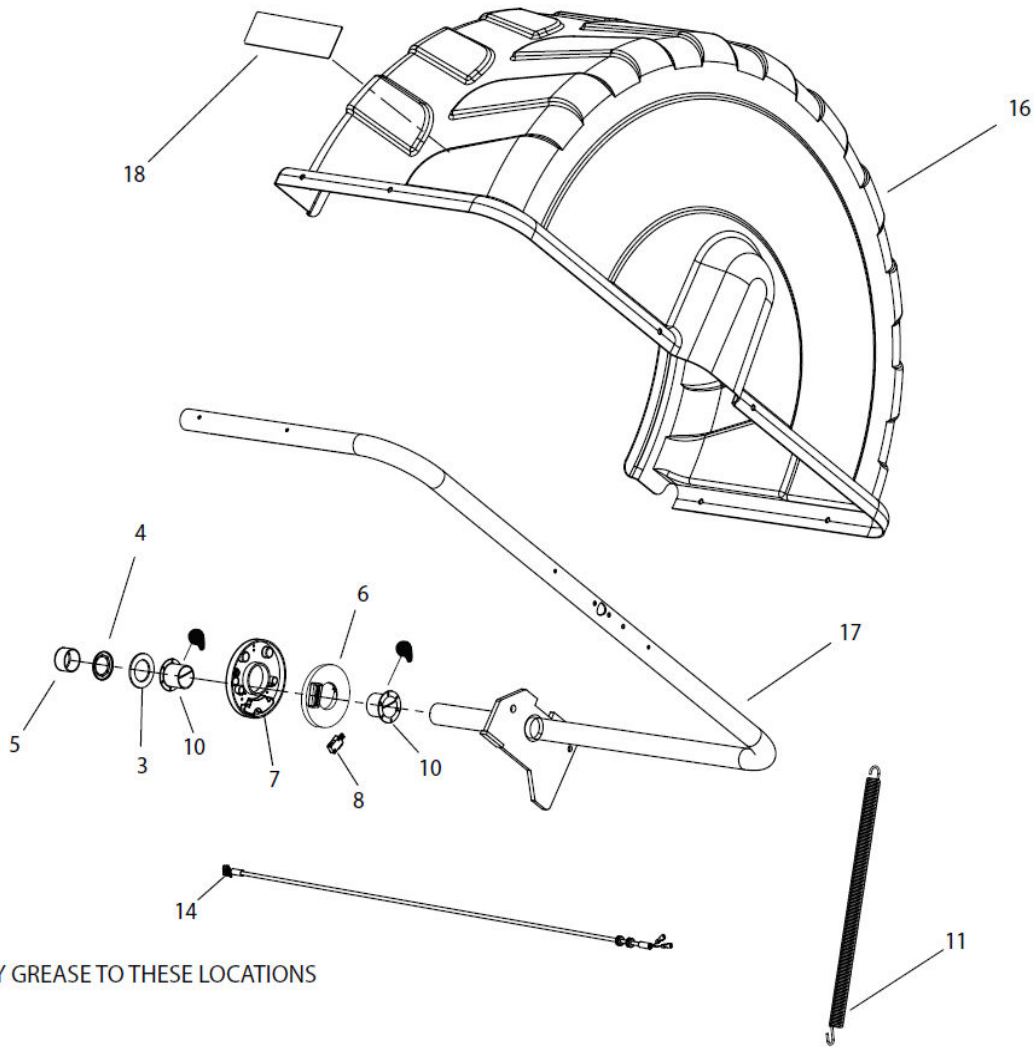

Item	Part No.	Description
1	8000745	1/4 Flat Washer
2	8109802	Screw, HHCS, 1/4-20 X 2.00
3	8109944	Washer - Hood Bar
4	8109945	Retainer - Washer 1 1/2"
5	85611317	Plug - Hood, w/Hole
6	8113332	Cam/Cover Hood Switch
7	8113333	Housing-Hood Switch
8	81133341	Switch-Micro, Limit
9	8181369	1/4-20 UNC Screw
10	8307014	Bearing - Flanged, Nylon
11	8308062	Spring - Hood, Extension
12	85000303	Bracket - Sonar
13	85000304	Sonar Module
14	85609820	Assy, Hood Switch Cable (1500 & 1600)
	85609868	Assy, Display Harness (1400 only)
	85610928	Assy, Display Harness (1300 only)
15	85610231	Cable-Sonar, Hood
16	85610517	Hood-Wheel
17	8114319	Weldment - Bar, Hood
18	85610679	Decal - Warning

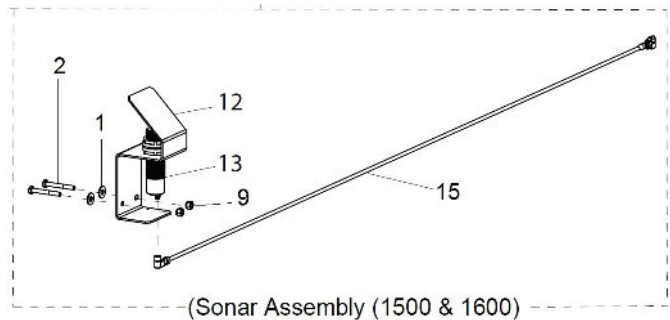



## Wheel Guard Hood Damper (1600 Only)

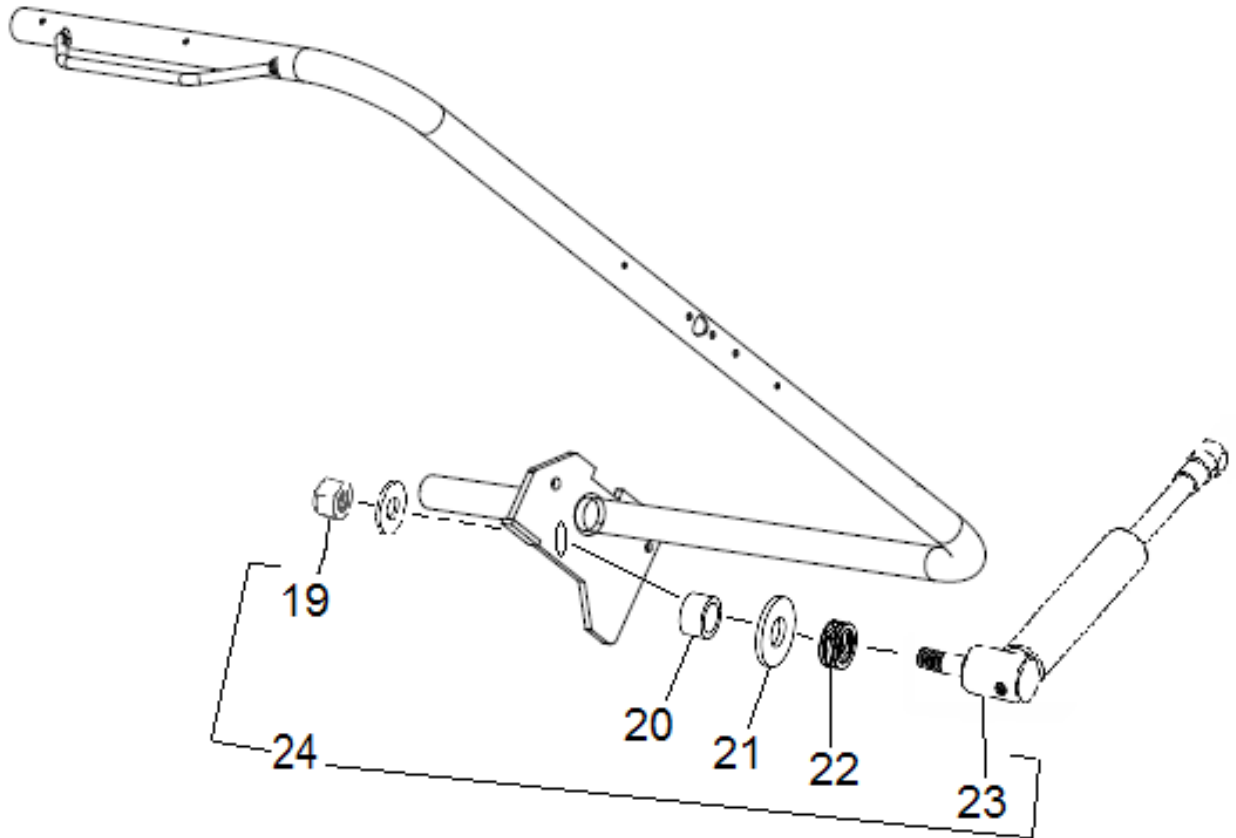

Item	Part No.	Description
19	8000525	Nut-Hex, Lk, 5/16-18
20	85610947	Bearing-Slve,Brnz
21	8000745	Flat Washer - 1/4
22	85611227	Spring - Comp, Hi-Load
23	85610951	Damper - Hood
24	85611231	Damper-Asm,Kit

# Chassis Assembly

Item	Part No.	Description
1	8106301	Screw-1/4-20 X .75
2	8106303	Nut - 3/8 - 16 UNC
3	8106304	Fastener - Skin, Tinnerman
4	85610661	Grommet-Inverter Port
5	8108727	Rod - Threaded
6	8110560	Screw - 8-32 UNC X .75" Lg.
7	8111029	Cover - Rear Harness
8	81142663	Assembly - Piezo
9	8301084	Nut, #8-32 Kep
10	8301120	Screw - HHCS
11	8301121	Washer, Plain .562idx1.375odx.109
12	8301112	1/2-13 Hex Nylock Nut
13	8309008	Molding - Stop, Hood
14	85606581	Grommet - Flex
15	85608850	Stud-Weight Tray
16	85610698	Bracket - Anti Tilt
17	85610571	Cover-Computer, Monitor

Item	Part No.	Description
18	85610578	Pad, Anti-Skid
19	85610583	Shield - Weight Tray
20	85610587	Assy-Tray, Laser Shield (Includes 85610588 & 85610274)
21	85611245	Assy-Display Computer
22	85610596	WLDMNT - Chassis, Split, Skirted
23	85610733	Cap - Plug
24	85610962	Black Shield (1300 & 1400)
	85610588	Laser Shield (1500 & 1600)
25	85610274	Plastic Rivet
26	85611020	Pedal Switch Harness
27	929195	Compression Spring
28	85609746	Foot Pedal Switch
29	8102278	Cotter Pin
30	85611015	Pedal Ops Decal
31	85611013	Pedal Grip Pad
32	85611000	Pedal Assembly
33	85610570	Tray Support Bracket
34	85610584	Tray Stringer
35	8106302	Screw, HHCS, 3/8-16X7/8, WHZLK, G5
36	85610944	Standoff-Stud, Ball, 10mm

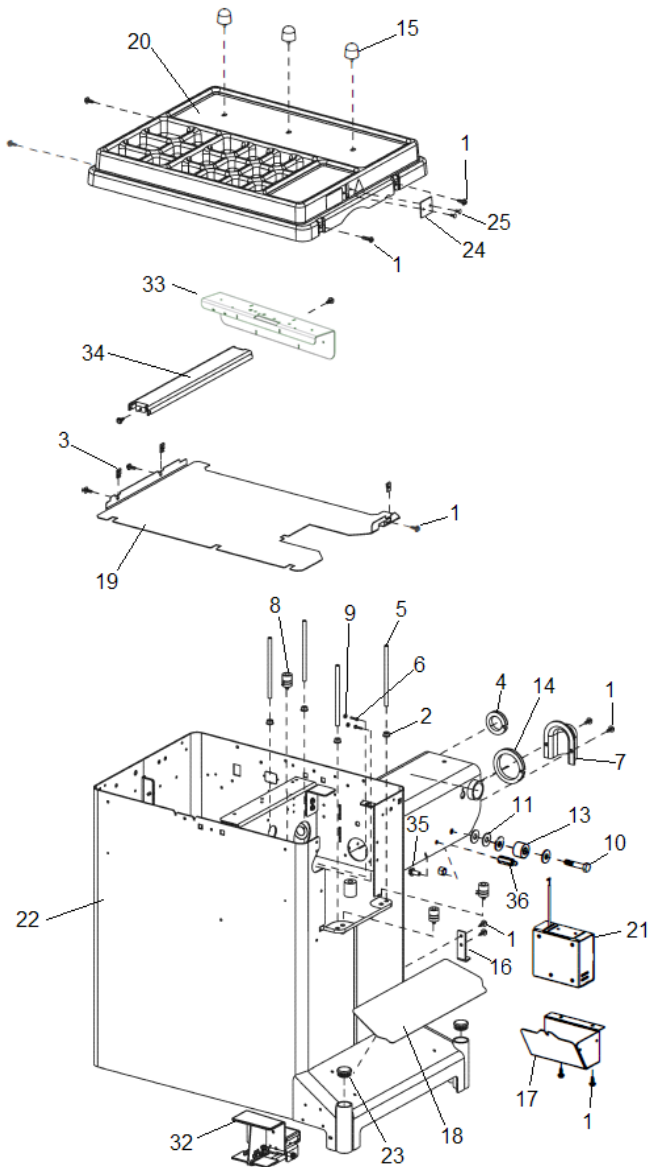

## Pedal Assembly (1600 Only - if equipped)

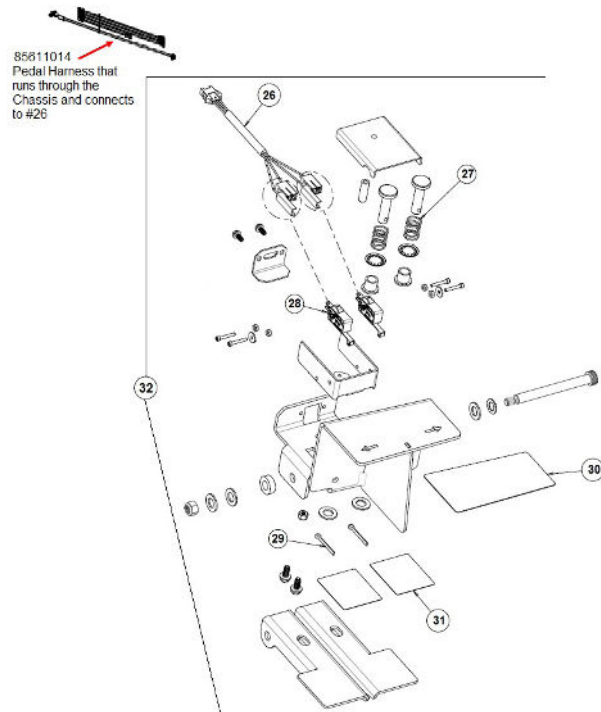

## Distance Gauge Assembly

Item	Part No.	Description	Item	Part No.	Description
1	8114254	A & D Pendulum	18	8111173	1/4-20 x 1-1/2 FHS Screw
2	8114251	A & D Bracket	19	8114380	Compression Spring
3	85609866	A & D Pots with Harness Assy	20	8114379	SHC 1/4-20 x 1-1/4 lg. Screw
4	85000730	Distance Rod Bushing	21	8114264	Hose Clamp
5	80180018	A & D Rod	22	8114255	A & D Tube
6	8114258	A & D Pot Bracket	23	85000731	Hex HD Cap Screw
7	8301084	#8-32 Kep Nut	24	8111032	1/4 Fender Washer
8	80180017	Distance Pot Pulley	25	8114373	Arm
9	80180022	String	26	903174	Retaining Ring
10	8114403	Pulley Collar	27	8301534	1/4-20 x 7/8 HHC Screw
11	8114404	10-24 x 3/4 SHSS Screw	28	8143169	1/4-20 Whiz Lock Hex Nut
12	80180020	Spring Bracket, 3MM Screw	29	8111542	#8-32 X 5/8" SEM Screw
13	80180021	Washer 3MM	30	8100964	1 1/4-inch Retaining Ring
14	80180019	String Bracket	31	85000732	A&D Arm Tube Assembly Kit
15	80180023	Spring	32	85609880	M6 x 12mm SHSSCP Screw
16	8114253	Cone			
17	85009229	Line Laser			

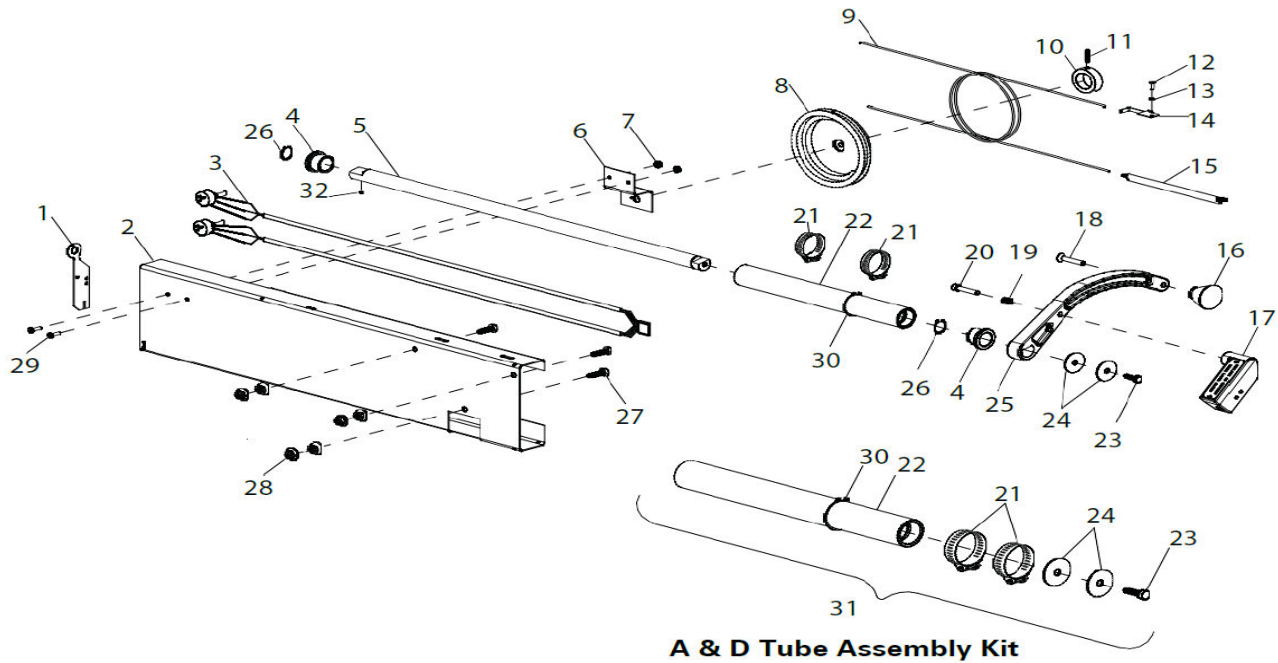

## Motor Assembly

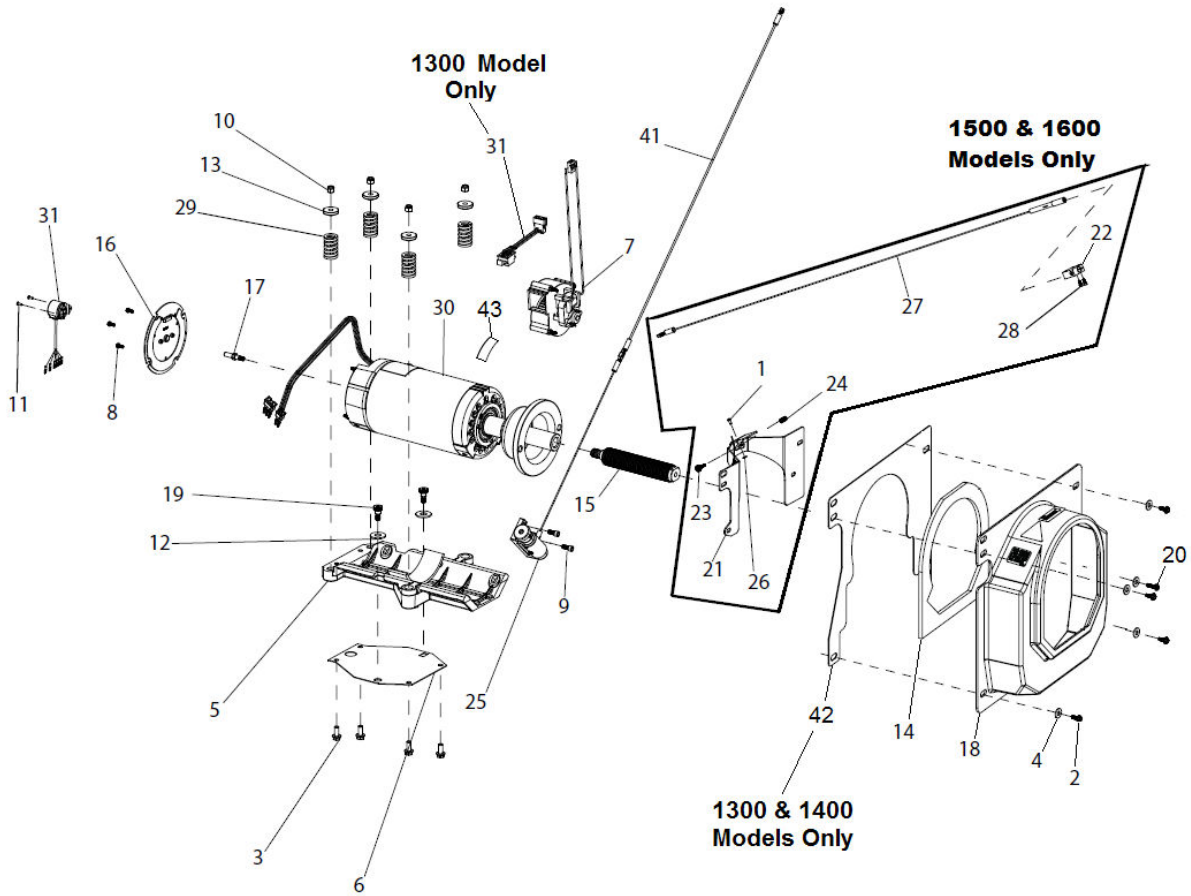

## Rotary Laser Assembly

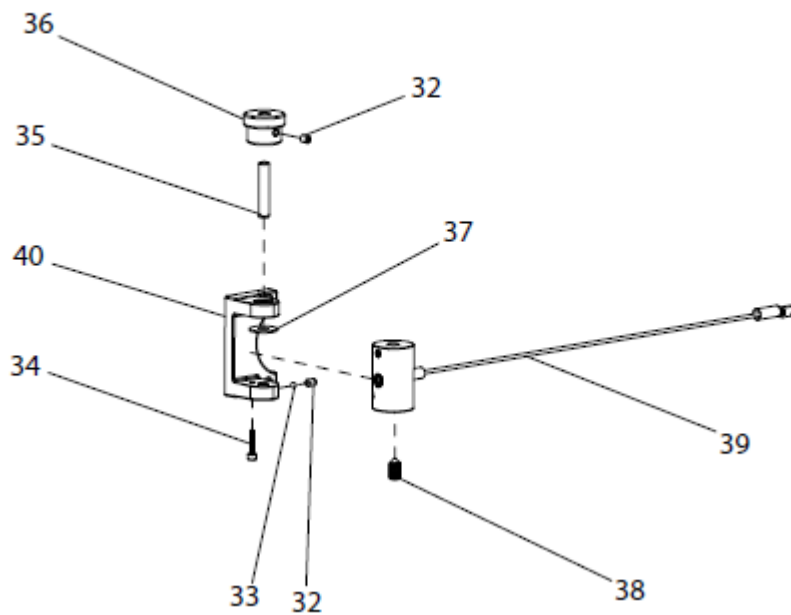

## Motor & Rotary Laser Assembly

Item	Part No.	Description	Item	Part No.	Description
1	920615	8-32 X .375 BHCS	23	85610273	Screw-Thumb, #8-32 X 7/8
2	8106301	Screw-1/4-20 X .75	24	85610275	Spring, .360 X 3/4"
3	8106302	Screw - HSWF, 3/8-16 X 7/8	25	85610280	Laser Assy-Rotary, Jst
4	8107635	Washer-Flat, 5/16	26	85610282	Washer, #8, Hard Fiber
5	8110430	Ass'y. - Cradle	27	85610536	Assy-Cable, Line, Laser
6	8112182	Flex - Plate	28	85610579	Screw-#8-32X3/8 SHCS
7	8114265	Assembly - Fan	29	85610682	Spring - Piezo, Precision
8	8144110	Screw - Hex Washer Head	30	85010010	Motor Replacement Kit (40mm)
9	8182149	Screw - SHC 5/16-18 X 3/4	31	85610094	Encoder (1500 & 1600)
10	8301035	Nut-3/8-16 Hex Nyloc		8110923	Encoder (1400)
11	8301067	Screw - #6-32 PHIL		8308817	Rotary Shutter (1400)
12	8301121	Washer, Plain .562 ID		8110923	Encoder Assembly (1300)
13	8308036	Retainer - Piezo Spring	32	902308	Set Screw
14	8308536	Motor Gasket	33	906407	Ball-Nyln, .187
15	85009204	Shaft-Extension, 40MM	34	928367	Screw, SHCS 10-24 UNC
16	85009970	Cover - Rear End Bell (1500 & 1600)	35	8114237	Dowel 3/8 X 2" LG.
	8308513	Cover - Rear End Bell (1400)	36	8114241	Knob
17	85009971	Shaft - Encoder Drive	37	8114242	Plastic Washer
18	85610748	Shroud-Motor, Assy (1400, 1500, 1600)	38	85610252	Screw-Set, Cn Pt,3/816,.75"LG
	85608997	Shroud-Motor, Assy (1300)	39	85610268	Cylinder Assy-Laser, Rotary
19	85609427	Bolt-SHSS, 1/2 X 3/8-16	40	85610399	Bracket-Assy, W/Brg
20	85609826	Screw-HWHMS, 1/4-20	41	85610265	Cable Assy - 36", JST
21	85610269	Bracket-Inboard Laser Posn	42	85609063	Motor Cover Shield (1300 & 1400)
22	85610271	Mount Block-12mm Dia Laser	43	85611016	Caution, Pinch Point (1600 - if equipped)

## Motor Shroud (1600 with Hood LED Bar & Switch)

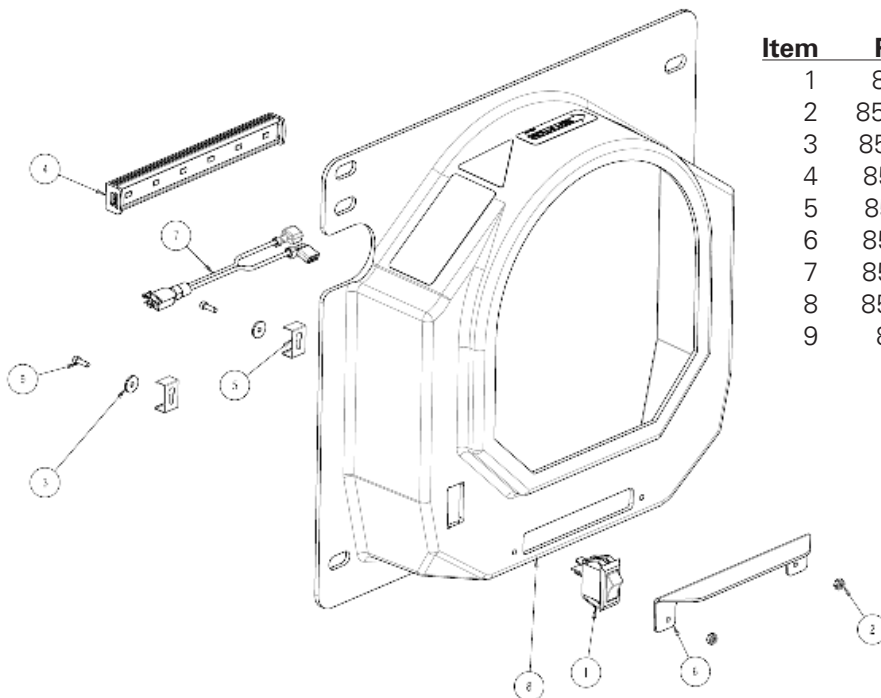

Item	Part No.	Description
1	8305802	Switch-ON/OFF
2	85000357	Nut - Nylok #4-40
3	85609410	Washer-#4 Flat, .125ID X .438OD
4	85611210	LED-6IN, Luxbar
5	85611211	Clip-Bar, LED
6	85611216	Hood-LED, Shroud
7	85611218	Harness-Power, LED
8	85611233	Shroud-Motor, ASM, Routed
9	8112073	Screw-BHCS, #4-40 X 1/2 LG.

## 1300/1400/1500 Monitor Assembly

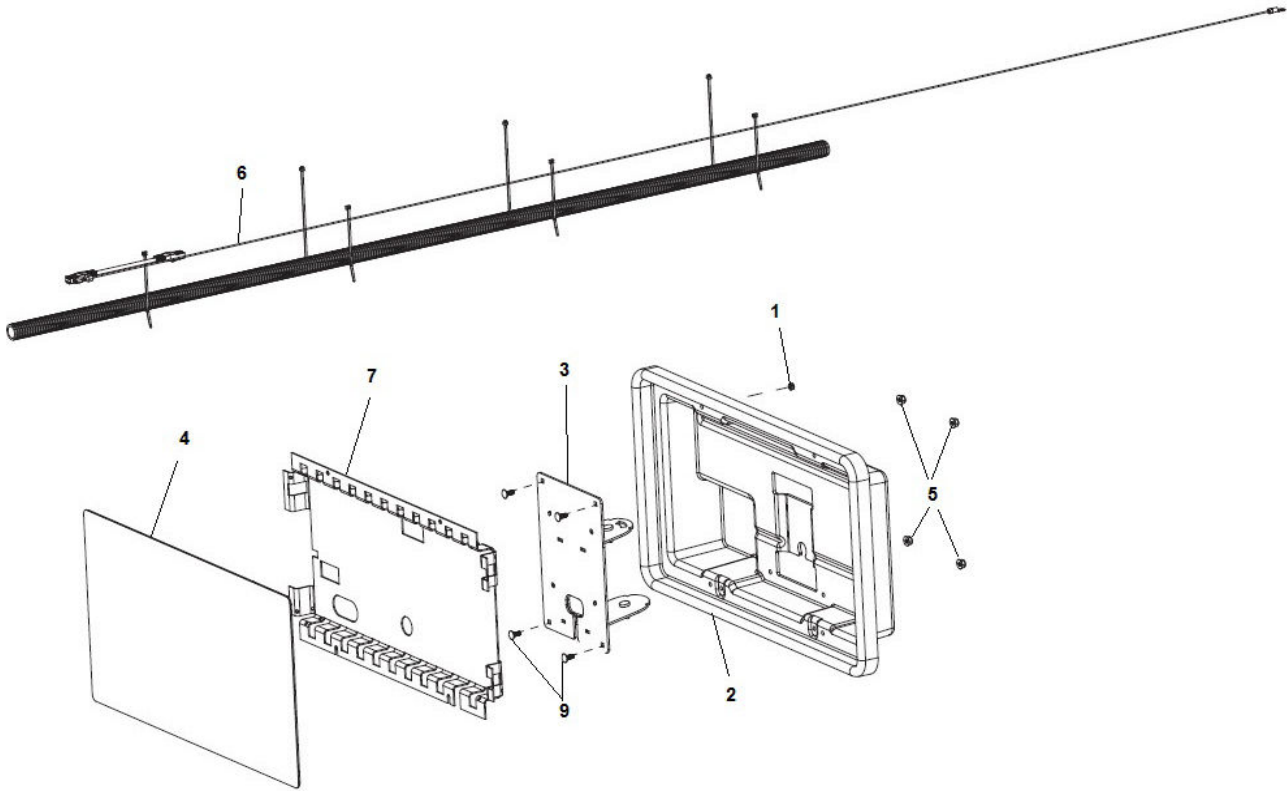

## 1600 Monitor Assembly

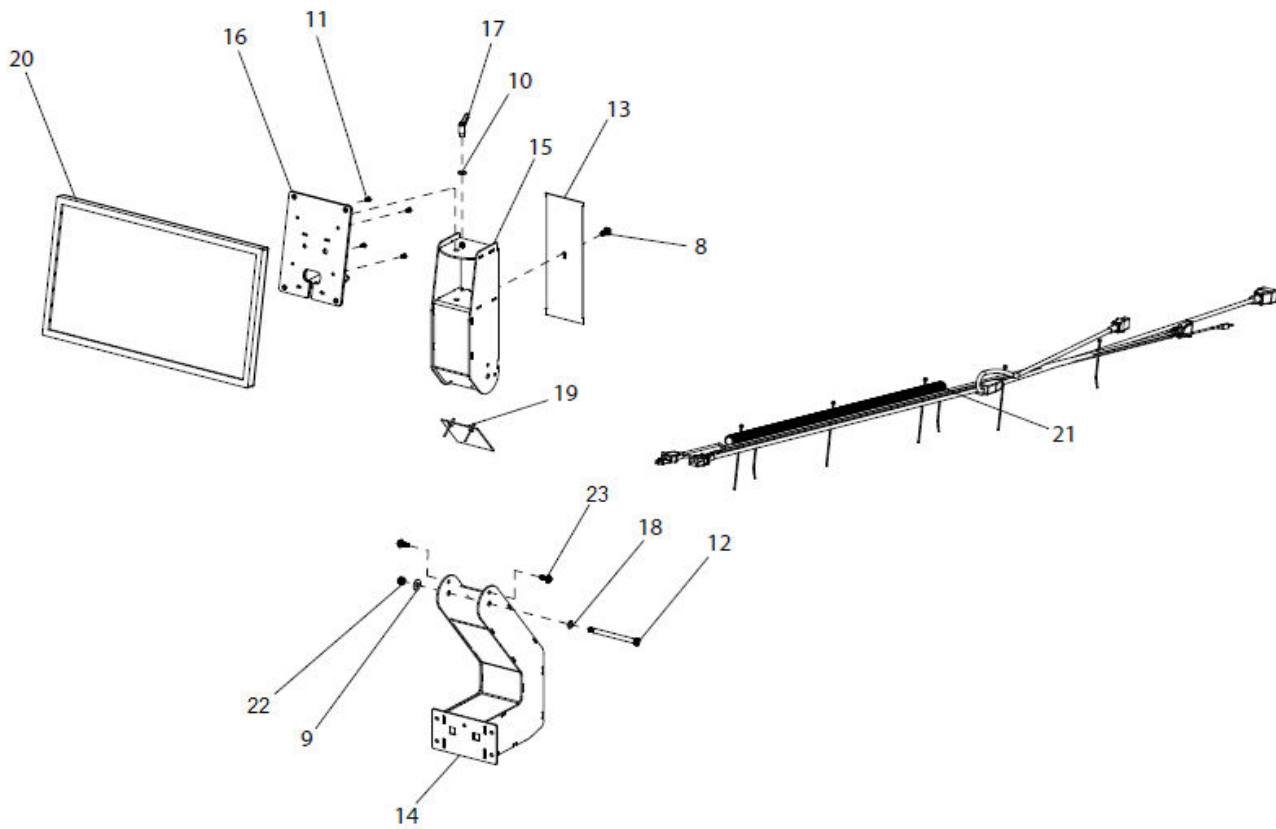

## 1300/1400/1500 Monitor Assembly

Item	Part No.	Description
1	8111055	Nut - Lock, W/Nylon Collar, #6-32
2	85610516	POD - Electronics
3	85610602	Wldmnt-Display Mount, Pvt Brkt
4	85610931	Assy-Panel, Tactile Touch (1300) (Includes PCB)
	85610896	<b>Panel</b> , Tactile Touch, <b>Only</b> (1300)
	85608097	<b>Board</b> -Panel,Touch, <b>Only</b> (1300)
	85610664	Assy-Panel, Tactile Touch (1400)
	85610663	<b>Panel</b> , Tactile Touch, <b>Only</b> (1400)
	85610624	Assy-Panel, Tactile Touch (1500)
	85610626	<b>Panel</b> , Tactile Touch, <b>Only</b> (1500)
5	85611520	Nut-Lock, #10-24, Nylon Insert
6	85610928	Assy-Cable, Tactile Panel (1300)
	85610629	Assy-Cable, Tactile Panel (1400/1500)
7	8113624	Shield - EMC (AUS Models only)
8	85610529	Mount-Cable, Snap-In, 8"
9	85611519	Bolt, Square-Neck Carriage, #10-24 x 0.5"

## 1600 Monitor Assembly

Item	Part No.	Description
9	8000745	Washer-Flat, 1/4"
10	8113921	Washer - Flat 1/4"
11	85607866	Screw-M4-07X10MM, Slotted Pan
12	85610288	Screw-Shoulder, 3/8 x 4
13	85610556	Plate-Pivot Backing
14	85610599	WLDMNT-Display Mount, Lower
15	85610601	WLDMNT-Display Mount, Upper
16	85610602	WLDMNT-Display Mount, Pvt Brkt
17	85610604	HANDLE-Display Mount, Locking
18	85610606	Washer-Fiber, 3/8" ID
19	85610607	Cover-Mat, 1/16" Rubber
20	85610608	Display-Viewsonic, 22" Touch
	85611176	Display-Viewsonic, 22" Capacitive
21	85610611	Cable-Asm, Display, Opt. Touch (for 85610608)
	85611170	Cable-Asm, Display, (for 85611168)
22	8000525	Nut-Hex, LK, 5/16-18
23	8106301	Screw-1/4-20 X .75

# 1300/1400 Non-Inverter Model

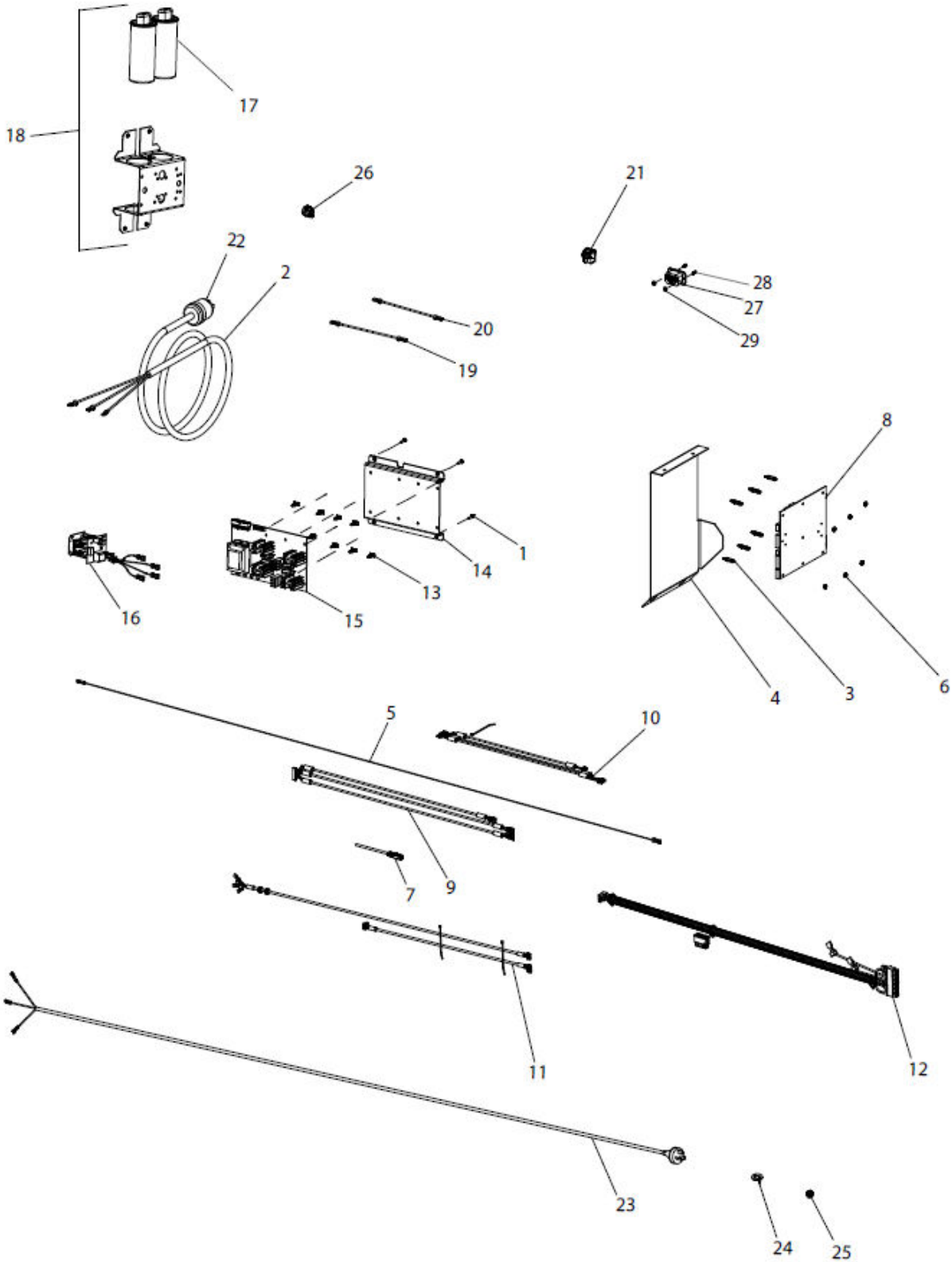



## 1300/1400 Non-Inverter Model

Item	Part No.	Description
1	8111542	Screw - 8-32 X 5/8 LG. Php Sem
2	85611137	Cord – Power
	8143127	Cord-Power 3 PH
3	8113996	Standoff - 8-32X3/4
4	8114184	Cover
5	8114212	Assembly, Drain Wire
6	8301084	Nut, #8-32 KEP
7	81142111	Cable - Cat 5, 7' LG.
8	85608097	PCB – Processor (1300 Only)
	85609809	PCB – Processor (1400 Only)
9	85609815	Assembly - Piezo Harness
10	85609818	Assembly, MCB Cable
11	85609868	Harness-Assy
12	85608188	Harness-Swtch,Hd,Assy
13	85000361	Standoff-Lck, Snp
14	85609308	Bracket-Mcb,Assy
15	85610543	Board-Asm,MCB,JST, 2D
16	85000705	Motor Module Assembly, 1 PH
	85000704	Motor Module Assembly, 3 PH
17	8112356	Capacitor
18	8111860	Capacity Panel Assembly
19	8309057	Wire-14AWG,RED,6",Assy
20	8309005	Wire-14AWG,BLCK,6",Assy
21	85609122	Switch-RCKR,DPST
22	8305076	220V, 1 PH Plug
	8140786	220V, 3 PH Plug
23	929507	Cord-Power, (Aust. Only)
24	929642	Adapter-Knckt, Heyco (Aust. Only)
25	929643	Relief-Strain,SR-6W-1 (Aust. Only)
26	906058	Relief-Strain,120V,SR-81-1
27	85609290	Outlet, Panel Mount
28	85610253	Screw, OHPMS, 6-32 x ½
29	8111055	Nut - Hex, locking, 6-32 Insert

# 1500/1600 Inverter Models

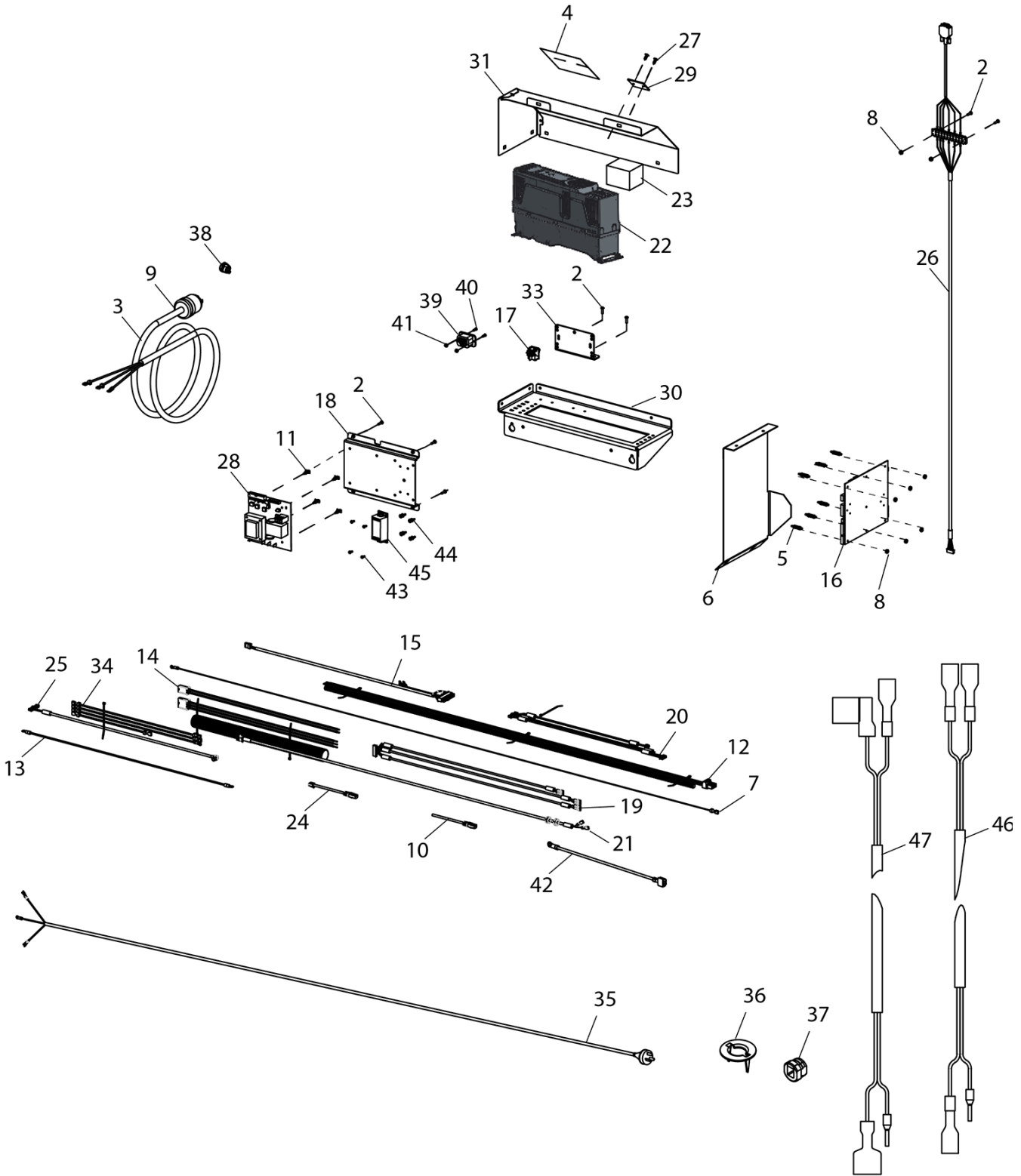

## 1500/1600 Inverter Models

Item	Part No.	Description
1	925019	Screw - Hex Hd. Self Tapping
2	8111542	Screw - 8-32 X 5/8 LG. Php Sem
3	85611137	Cord - Power 1 PH
	8143127	Cord - Power 3 PH
4	8113927	Decal-Caution/Warning
5	8113996	Standoff - 8-32X3/4
6	8114184	Cover
7	8114212	Assembly, Drain Wire
8	8301084	Nut, #8-32 Kep
9	8305076	Plug-Twist Lock,250V,20AMP,1PH
	8140786	Plug-Twist Lock,220V,20AMP,3PH
10	81142111	Cable - CAT 5, 7' LG.
11	85000361	Standoff- Snap-Lock
12	85010022	Assy - Wire Harness, Motor
13	85010024	Assy - Wire, Ground X 26' LG.
14	85600284	Harness - Inverter / Motor
15	85608188	Harness-Fan 220V,Assy
16	85609808	PCB - Processor (1500)
	85608629	PCB - Processor (1600)
17	85609122	Switch-DPST, Rocker
18	85609308	Bracket-MCB Assy
19	85609815	Assembly - Piezo Harness
20	85609818	Assembly, MCB Cable
21	85609820	Assy, Hood Switch Cable
22	85609942	Inverter-Emerson 701, 3HP
23	85610071	Damper, Vibration, Inverter
24	85610107	Cable-RJ45 - RJ12 Assy
25	85610232	Cable, Sonar Chassis (1500 only)
	85611014	Cable, Sonar Chassis, Pedal (1600 only)
26	85610237	Cable-Emrsn,W/Trmnl,Assy
27	85610274	Rivet-Plastic, A3/16"
28	85610527	Board-Supply,Power,Inverter
29	85610588	Shield-Acrylic, IB Laser
30	85610644	Bracket-Inverter, Reverse
31	85610645	Weldment-Cover, WND
33	85610649	Bracket-Terminal Strip, Side
34	85610672	Harness-Asm,Pwr, 4X 14AWG
35	929507	Cord-Power, (Aust. Only)
36	929642	Adapter-Knckt,Heyco (Aust. Only)
37	929643	Relief-Strain,SR-6W-1 (Aust. Only)
38	929643	Relief-Strain,120V,SR-81-1
39	85609290	Outlet, Panel Mount
40	85610253	Screw, OHPMS, 6-32 x 1/2
41	8111055	Nut - Hex, locking, 6-32 Insert
42	85610727	Ground Wire
43	8301067	Screw- #6-32 X Phil. (1600 with LED Bar Only)
44	85611225	Spacer-Snap-In,ML/FML (1600 with LED Bar Only)
45	85611226	Supply-Pwr, 220VAC/24VDC (1600 with LED Bar Only)
46	85611222	Harness-Pwr,Switch, 48"
47	85611223	Harness-Pwr,LED, 48"

