

# COATS®

## 19,000 lb. (8,618 kg)

### Closed Front Four Post Lifts

Double Wall Runways with "Z" Rails, Built-in  
Radius Plate Pockets & Rear Slip Plate

4T419CSAR1 (Standard Alignment)

4T419CXAR1 (Extended Alignment)

4T419CSSR1 (Standard Service)

4T419CXSR1 (Extended Service)



## Installation Manual Operation Manual Service Parts Manual

READ the manual thoroughly before installing, operating, servicing, or maintaining the lift. SAVE this MANUAL and ALL INSTRUCTIONS.

**HENNESSY**  
INDUSTRIES

1601 J.P. Hennessy Drive, LaVergne, TN 37086 (800) 688-6496 or (615) 641-7533

Hennessy Canada: 2430 Lucknow Drive, Unit 9, Mississauga, Ontario L5S 1V3 (905) 672-9440 [www.coatsgarage.com](http://www.coatsgarage.com)

HENNESSY INDUSTRIES INC. Manufacturer of AMMCO®, COATS® and BADA® Automotive Service Equipment and Tools.

Manual Part No.: 85611161 00

Revision: 6/17

Your new lift will provide years of dependable service if installed, operated and maintained properly. **Follow all safety, installation, operation, and maintenance instructions in this manual before installing and operating the lift. In addition, follow all safety and other information included on and with the lift before operating the lift. Keep this manual in a secure place for future reference, training and service part identification.**

## **TABLE of CONTENTS**

1. Unloading Procedure and Lift Package Contents	page 3
2. Important Safety Instructions	page 5
3. General Requirements and Lift Specifications	page 8
4. Tools Required and Pre Installation Procedures	page 9
5. Installation Procedures	page 12
6. Operating Instructions and Lift Maintenance	page 14
7. Troubleshooting	page 17
8. Lift Installation Diagrams and Parts Lists	page 19

**IMPORTANT** : It is the shop owner's responsibility to provide a satisfactory installation area for the lift. Lift should only be installed on level concrete floors with no more than 3° of slope and with a minimum of 4 inches (102mm) and 3000 psi (20.7MPa) concrete that has been aged a minimum of 30 days. Please consult a qualified individual if any doubt exists concerning proper installation and subsequent safe operation of the lift. Do not install the lift on asphalt or outdoors. Failure to comply with these minimum standards could result in personal injury or death.

Prior to installation, it is the shop owner's responsibility to provide constant electrical power in the correct voltage, phase, etc., and all wiring for electrical hook-up of the lift. The shop owner must insure that the electrical installation conforms to local building and safety codes. Where required, the shop owner will provide an electrical isolation switch located in close proximity to the lift. This switch will have an emergency stop capability and isolate electrical power from the lift for servicing requirements.

Hydraulic oil cannot be shipped with the lift and will be supplied by either the shop owner or the installer. ISO 32 hydraulic oil (10W non detergent hydraulic oil) must be used to fill the reservoir tank before operating the lift.

**It is the shop owner's responsibility to train all operators in lift operation and lift safety.**

## **UNLOADING PROCEDURE and LIFT PACKAGE CONTENTS**

### **For your information:**

All lift components are packaged together in one module held together by steel frames  
Optional accessories (rolling jacks and turnplates) are packaged separately.

### **UNPACKING PROCEDURE:**

When the lift arrives on site:

- If possible have lift unloaded in the installation area and on two 4"x 4" x 24" Wooden Blocks (required for unpacking)
- Check for freight damage and report immediately to the trucking company who delivered the lift
- Check for missing parts and report immediately to the factory  
1 - 877 - 799 - LIFT (5438) or (905) 847 - 1198

### **Main Components include:**

Columns – 4 pc  
Runway Assemblies – 2 pc  
Crossmembers – 2 pc (1 front – 1 rear)  
Approach Ramps – 2pc  
Accessory and Hardware Box (see list below)  
Powerpack – 1 pc

### **Optional Accessories: (included only if ordered)**

Rolling Air/Hydraulic Jacks - 1 jack per box c/w coiled air line  
Turnplates - 1 turnplate per box c/w retainer brackets

### **Accessory Box includes:**

Lifting (equalizing) Cables - 4  
Hydraulic Hose – 1 pc  
Wheel Stops - 2  
WL 200 Series Safety Information Label Kit  
ALI - "Lifting It Right " Manual  
ALI - "Vehicle Manufacturer's Lifting Point Guide" (CD)  
Automotive Lift Safety Tips Hang Card  
Automotive Lift, Operation, Inspection and Maintenance Manual  
Owner's Manual

**Hardware Box includes:** fittings, bolts, washers, nuts, anchor bolts, etc.



## **Important Notice**

**Krown Rust Proofing has been applied to specific areas of your new lift to ensure protection from corrosion.**

- Please do not be alarmed if fluid is noticed dripping from openings of the Drive on Runways. This is normal.
- The application of the Krown Rust Proofing is completed in the final stage of the lift assembly process. To ensure protection and coverage, a generous amount is sprayed and may still be in a more fluid phase of its setup when your new lift is put into service. This will diminish over time, while maintaining protection of areas that are unable to be otherwise protected with paint coating.

# **IMPORTANT SAFETY INSTRUCTIONS**

When using your garage equipment, basic safety precautions should always be followed, including the following:

1. Read all instructions
2. Care must be taken as burns can result from touching hot parts
3. Do not operate equipment with a damaged cord or if equipment has been dropped or damaged – until it has been examined by a qualified service person
4. Do not let a cord hang over the edge of the table, bench, or counter or come in contact with hot manifolds or moving fan blades
5. Let equipment cool completely before putting away. Loop cord loosely around equipment when storing
6. To reduce risk of fire, do not operate equipment in the vicinity of open containers of flammable liquids (gasoline)
7. Adequate ventilation should be provided when working on operating internal combustion engines
8. Keep hair, loose clothing, fingers, and all parts of body away from moving parts
9. To reduce the risk of electric shock, do not use on wet surfaces or expose to rain
10. Use only as directed in this manual. Use only manufacturer's recommended attachments
11. ALWAYS WEAR SAFETY GLASSES. Everyday eyeglasses only have impact resistant lenses, they are not safety glasses

## **SAVE THESE INSTRUCTIONS**

**safety cont'd on page 5**

### **Safety Continued:**

Basic common sense safety precautions should always be followed when installing, operating and maintaining the lift as a risk of fire, electric shock, injury or death may be present.

### **In addition:**

1. Read and follow all safety instructions and decals included with the lift. Read and follow all safety instructions in this manual. Read and follow the ALI "Lifting It Right" manual (included with the lift). Always use the "Vehicle Lifting Points" reference guide when lifting a vehicle. Insure all materials stay up to date >>> [www.autolift.org/](http://www.autolift.org/)
2. Only trained and authorized personnel should position a vehicle and operate the lift. Do not allow customers or bystanders to operate the lift or be in the lift area.
3. Inspect the lift daily. Do not operate if potential problems have been identified or lift malfunctions. Do not operate if lift has damaged or broken components. Never walk or work under the lift unless all safety locks are completely engaged.
4. Never overload the lift. The rated capacity decal is located on the powerpack column. The hydraulic system on this lift is not designed to be a load holding device. Mechanical safety locks must be engaged before proceeding under the lift for vehicle servicing or lift

maintenance. Never override operating controls. This is unsafe and will void the warranty.

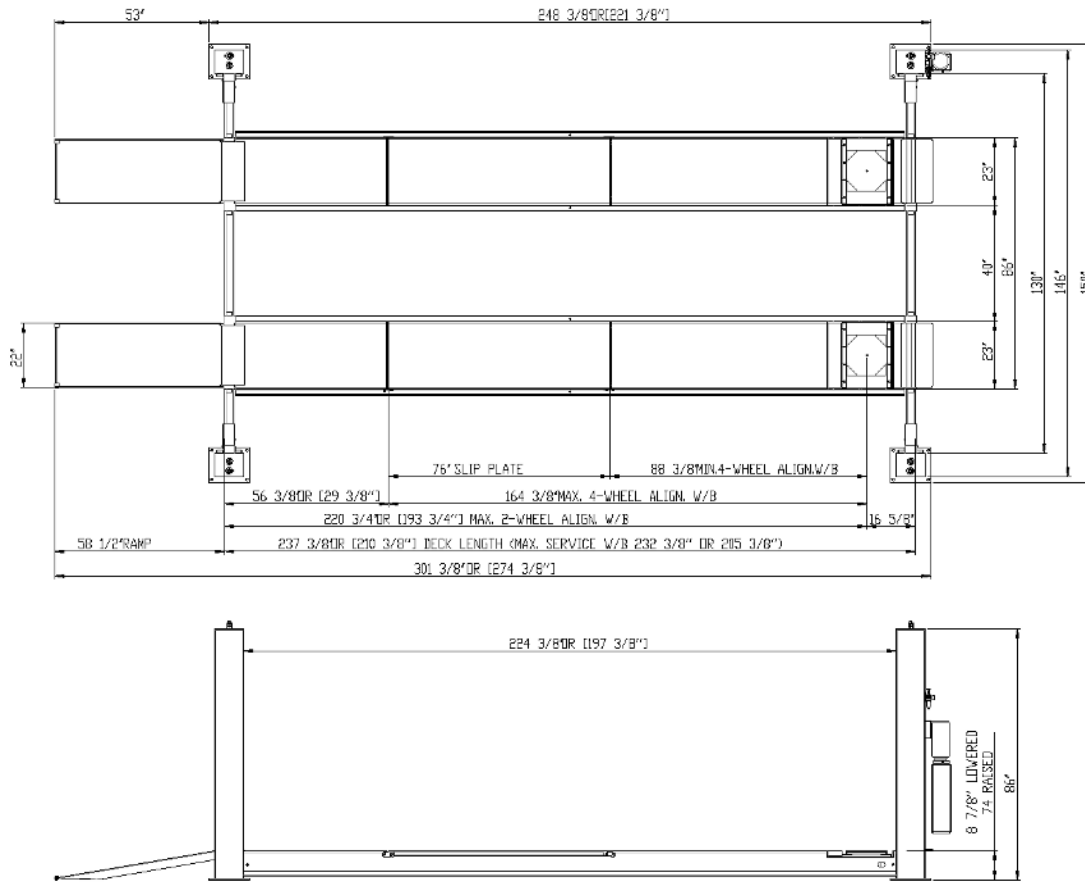
5. Before driving a vehicle onto the lift, insure that both slip plates and turn plates have all lock mechanisms securely in place. Also insure that the lift and lift area is clear of all debris and that all oil and grease has been cleaned from runway surfaces.
6. Before raising or lowering the lift, always totally secure the vehicle with wheel chocks.
7. When using a jack(s) to raise a vehicle, position jack lifting pads to contact vehicle manufacturers recommended lifting points. Raise jack slowly until all pads contact the vehicle. Confirm that the vehicle is stable on the jack(s) before raising to desired working height.
8. Some pickup trucks may require optional truck adapters to clear running boards and other installed accessories. Special care must be exercised with pick-up trucks to insure safe lifting. Always use vehicle manufacturers lifting points and insure the contents of the cargo box will not affect vehicle balance while on the jack(s).
9. Important: Removal or installation of heavier parts can change the vehicle's center of gravity on the jack(s) resulting in a critical load shift. The vehicle may then be unstable. Plan ahead for this possibility to insure continued safety and refer to the vehicle manufacturer's service manual for recommended procedures.
10. Always keep the lift area free of obstructions and debris. Grease and oil spills should be cleaned up immediately.
11. Never raise a vehicle on the lift with passengers inside. Before lowering, check the lift and lift area and remove all obstructions. Before removing vehicle from the lift or lift area, confirm an unobstructed exit.
12. DO NOT PERFORM ANY MAINTENANCE OR INSTALLATION OF ANY COMPONENTS WITHOUT FIRST ENSURING THAT ELECTRICAL POWER HAS BEEN DISCONNECTED AT THE SOURCE OR PANEL AND CANNOT BE RE-ENERGIZED UNTIL ALL MAINTENANCE AND/OR INSTALLATION PROCEDURES ARE COMPLETED (ANSI 244.1).

# Safety Instruction and Information Decal Kit (included with the lift)

<b>Automotive Lift Institute, Inc.</b>		<b>WL200 Series Label Kit</b>	
<p><b>CAUTION</b></p> <p>Do not operate a damaged lift.</p>	<p><b>CAUTION</b></p> <p>Read operating and safety manuals before using lift.</p>	<p><b>WARNING</b></p> <p>Clear area if vehicle is in danger of falling.</p>	<p><b>WARNING</b></p> <p>Remain clear of lift when raising or lowering vehicle.</p>
<p><b>Review all safety information daily with all lift operators</b></p>		<p><b>WARNING</b></p> <p>Keep clear of pinch points when lift is moving.</p>	<p><b>WARNING</b></p> <p>Keep feet clear of lift while lowering.</p>
<p><b>IMPORTANT:</b></p> <p>Read operating and safety manuals before using lift.</p>	<p><b>IMPORTANT:</b></p> <p>Proper maintenance and inspection are required for safe operation.</p>	<p><b>WARNING</b></p> <p>Do not override self-closing lift controls.</p>	<p><b>WARNING</b></p> <p>Check wheel to prevent vehicle movement.</p>
<p><b>Decals and Hang Card are affixed to the lift immediately following installation and before the lift is used</b></p>		<p>The messages and pictographs shown are generic in nature and are meant to generally represent hazards common to all automotive lifts regardless of specific style.</p> <p>Funding for the development and validation of these labels was provided by the Automotive Lift Institute, PO Box 85 Cortland, NY 13045.</p> <p>Replacement label sets may be obtained from the original lift manufacturer and ALI's member companies. They are protected by copyright.</p> <p>www.autolift.org ©1992 by ALI, Inc. ALIWL200w</p>	

**LIFT SAFETY and LIFT MAINTENANCE  
MUST BE PART OF YOUR DAILY ROUTINE**

## **GENERAL REQUIREMENTS and LIFT SPECIFICATIONS**



**19,000 lb. (8618 kg) Capacity - 9,500 lbs. (4309 kg) each Runway**

Capacity	Wheel Base
Min. Wheelbase @ Rated Capacity	180"
Min. Wheelbase @ 75% Capacity	140"
Min. Wheelbase @ 50% Capacity	100"
Min. Wheelbase @ 25% Capacity	60"

**Lift should only be installed on level concrete floors with no more than 3° of slope and a minimum of 4 inches (102mm) and 3000 psi (20.7MPa) concrete that has been aged a minimum of 30 days. Do not install the lift on asphalt or outdoors.**

**A constant supply of 230 volt – 1 phase – 60 Hz – 30 amp electrical power is required for this lift.**

Ongoing design modifications and quality improvements may change specifications listed in this manual without notice



## TOOLS REQUIRED and PRE INSTALLATION PROCEDURES

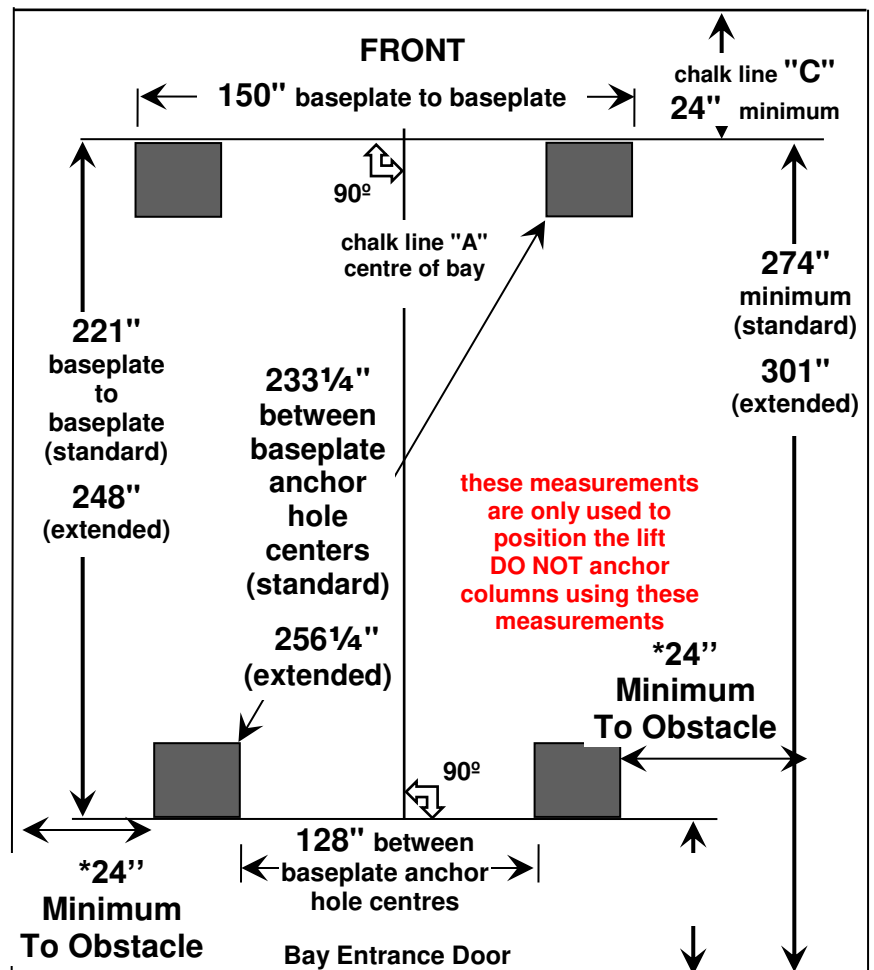
### Tools Required:

- ✓ 30ft. Measuring Tape - Chalk Line and Chalk
- ✓ 4"x 4" x 24" Wooden Blocks
- ✓ Fork Lift - Floor Jacks (2) - or engine crane
- ✓ Work Stands - 4 (runway set-up and installation)
- ✓ Metric and SAE Wrenches and Ratchet Sets
- ✓ Metric and SAE Allen Key Sets
- ✓ Crow Bar - Hammer - Screwdrivers
- ✓ 2 x 4 ft. Level (laser level also suggested)
- ✓ Rotary Hammer Drill c/w 3/4 inch diameter Masonry Drill Bit
- ✓ Step Ladder

### PRE-INSTALLATION PROCEDURE

Before proceeding with installation, read the installation manual and insure all instructions are fully understood and all component parts listed on page 3 are accounted for.

Identify bay center line near the front and mark the floor. Also mark center of the bay entrance. Connect these two points with a chalk line "A". Refer to diagram at right for minimum clearance from bay entrance door and draw a second chalk line "B" at 90° to the centerline. Refer to diagram at right and mark approximate locations of two rear columns. Refer to the diagram at right for measurements and minimum clearance from front wall or work bench and draw a third chalk line "C" at 90° to the centerline. Refer to diagram at right and mark the locations of all four columns. **These locations will be used to initially position each column, however, the 4 most critical measurements will be inside column to inside column measurements confirmed later in the installation process.**



**\*keep 24" min. space or follow local safety/building code.**

### Pre Installation continued

Confirm that the column baseplate locations you have marked are a minimum distance of six (6) inches from any floor seam. Do not install if floor has cracks or deterioration that could affect lift stability. The shop owner is responsible for confirming there are no obstructions in the installation area like floor drains, under floor piping or electrical conduit that could be damaged or prevent safe lift installation and secure lift anchoring. Check ceiling for beams or heating ducts and walls for protruding structures, etc. (overhead clearance must be 84 inches plus the height of the tallest vehicle you want to lift). Insure that the lift can be safely installed in the position you have marked out on the bay floor.

## **INSTALLATION PROCEDURE**

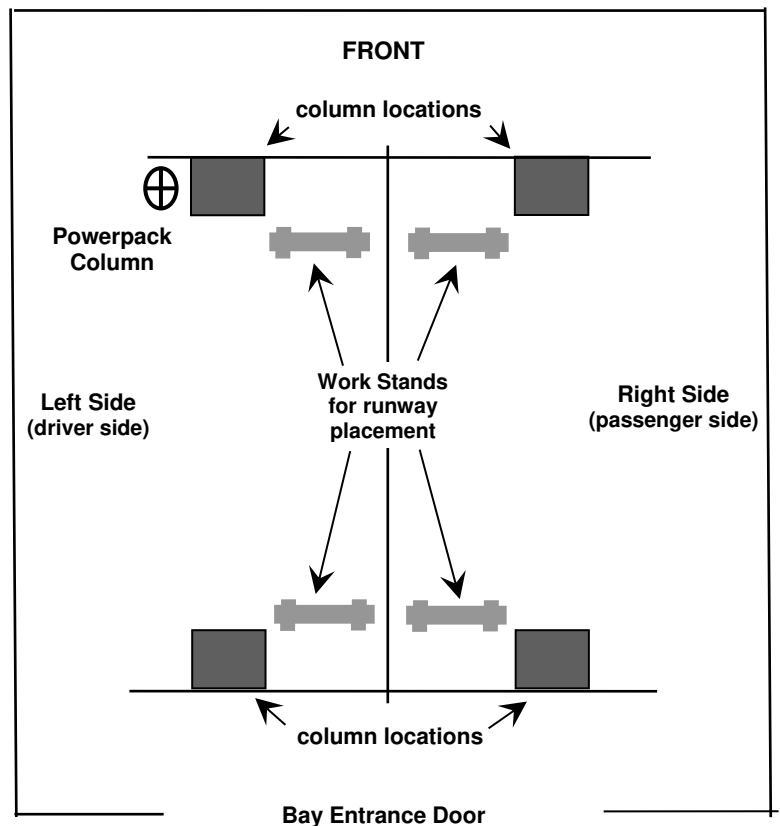
Insure the lift installation complies with ANSI/ALI/ALIS, Safety Requirements for Installation and Service of Automotive Lifts.

1. Remove protective wrapping from the lift and clear installation area of packaging materials. Place two 4"x4"x 24 " wooden blocks under the lift to enable fork lift or other access and to allow for removal of shipping frames. Unbolt steel shipping frames and remove from installation area. Take adequate precautions when working with runways, columns and other components.

2. Work stands are recommended for safety and ease of runway and carriage assembly. As an alternative, use wooden blocks to raise runways off the floor. Position work stands (or wooden blocks) as shown in the diagram to the right.

3. Identify front crossmember and set it securely on top of front work stands. Insure the end with 2 single pulleys is next to the powerpack (driver side) column.

4. Place one front column into each end of the front crossmember insuring the guide blocks are centered in the column walls.



5. Carefully lift rear crossmember and set it securely on top of the rear work stands. Insure the end with 2 double pulleys is on the same side as the powerpack (driver side) column and inline with the front crossmember single pulley (reference diagram #5 - cable routing).

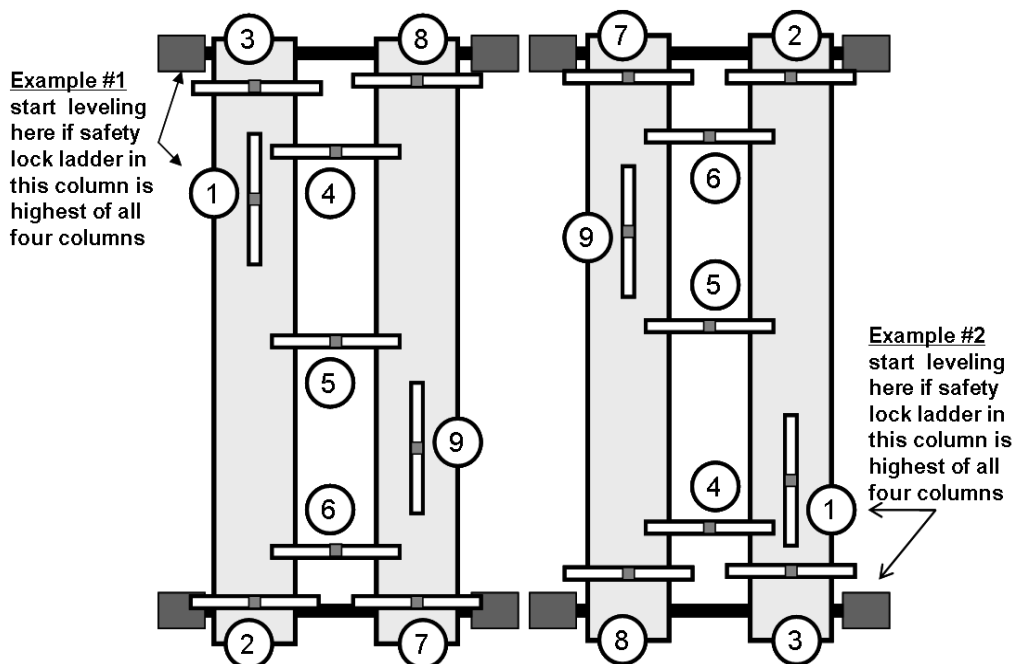
7. Place one rear column into each end of the rear crossmember insuring the guide blocks are

centered in the column walls.

8. Carefully lift the left (driver side) runway and set it securely on top of both front and rear crossmembers. Confirm this runway has the hydraulic cylinder underneath. Also confirm this runway has the hydraulic hose connection located at the front next to the powerpack column. Alignment turnplate pockets are always at the front. Insure that both the front and rear of the runway is seated properly on both crossmembers. If the runway does not seat properly on both crossmembers, carefully move one or both crossmember and column assemblies slightly to fit on its crossmember support.
9. Carefully lift the right (passenger side) runway and set it securely on its support on top of both front and rear crossmembers.
10. Route the lifting/equalizing cables as shown in diagram #5. Insure that no cable is crossed during this process. **IMPORTANT:** Insure all cables are completely contained and properly seated in each sheave groove.
11. Secure each of the four cables in the wire rope anchor located at the shaft end of the hydraulic cylinder.
12. Attached each cable to the proper column top plate using a washer,  $\frac{3}{4}$ " nut and jam nut (reference diagram #4).
13. Use a 4 ft. level to insure each column is vertically plumb and at a 90° angle to the crossmember. Also insure opposite columns for each crossmember are symmetrical in configuration. Make only minor adjustments to accomplish this.
14. Reconfirm column level and symmetric position relative to crossmember and opposite column. Starting with the left front (powerpack) column, drill anchor bolt holes and install anchor bolts (reference diagram #6).
15. Reconfirm column level and symmetric position relative to crossmember and opposite column for each of the three remaining columns. Drill and install anchor bolts (reference diagram #6).
16. Install runway approach ramps and wheel stops.
17. Install powerpack (reference diagram # 8 and #9).
18. Route and connect hydraulic hose (reference diagram #10).
19. Route air line and connect to air solenoid (reference diagram #10).
20. Fill powerpack reservoir with ISO grade 32 hydraulic oil.
21. Confirm electrical wire is sized for a minimum 30 amp circuit and supplying 208/230 volts. Use a separate circuit for each powerpack. Protect each circuit with a time delay fuse or circuit breaker. For single phase power use a 20 amp fuse. For three phase power use a 15 amp fuse. For 400 volt service and above use a 10 amp fuse. All wiring must comply with national and local codes.
22. **NOTE:** All electrical wiring should be installed and connected by a certified electrician.

Connect powerpack to shop electrical system.

23. Connect air solenoid to shop air system.
24. Press the manual over-ride button on the air solenoid and confirm that all four safety latches are working properly. Confirm there are no leaks in the air system.
25. Raise the lift 2 - 3 ft. while checking for proper direction of rotation on the electric motor. Confirm there are no leaks in the hydraulic system.
26. Lower the lift (you may first have to raise the lift slightly to disengage the mechanical safety locks). When lowering, continuously hold down both the air valve and hydraulic lowering valve.
27. Raise and lower the lift several times to remove any air from the hydraulic system.
28. Raise the lift 3 ft. and confirm that all four safety latches engage and disengage completely.
29. Refer to diagram at bottom. Commence adjusting the level of both runways by tightening or loosening the wire rope (cables) using the  $\frac{3}{4}$ " NC Hex Nut at the top of each column.
30. FINAL TEST: Raise the lift to its highest limit and continue to hold the "UP" switch on the powerpack for about four (4) seconds. This will test the lifting system for maximum load capacity. Following this test, check for leaks and tighten any loose connections.
33. Use plastic ties and clamps to secure all hydraulic and air lines that droop or hang down from the lift. **Insure that no hydraulic or air line comes in contact with any lifting cable.**



34. **Operate the lift with a vehicle.** Raise and lower the lift three times. Confirm all the operational functions, equalizing cables and safety lock work well.

**Insure this manual along with all operation, inspection and maintenance instructions are delivered to the owner/user/employer**

**LIFT OPERATION:** Before lifting a vehicle, insure all operators are qualified, have been trained and are following all safety instructions. Read and follow the ALI "Lifting It Right" manual included with the lift. **Always** use the "Vehicle Lifting Points" reference guide when lifting a vehicle. Insure all materials stay up to date >>> [www.autolift.org/](http://www.autolift.org/) (see example of SAE J2184 standard below)

Insure that every vehicle will be securely positioned on the lift (use wheel chocks). When using air/hydraulic rolling jacks, always use vehicle manufacturer's recommended lifting points. **Never allow anyone under the lift when raising or lowering. Always insure mechanical safety locks are completely engaged on all four columns before proceeding under the lift or a vehicle.**

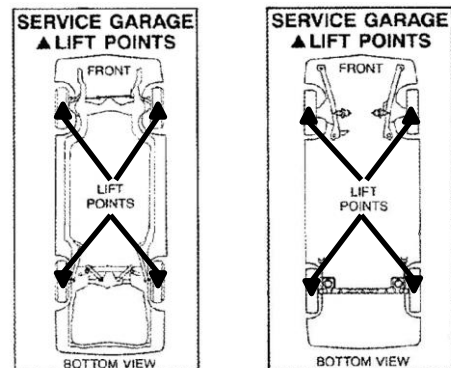
**Lift Operation:** Controls on the powerpack and powerpack column perform the following functions:

Raise the lift to the desired height by pressing the push button on the power unit  
- "ON / OFF SWITCH" raises the lift.

- "AIR LOCK RELEASE BUTTON" retracts or releases safety locks at all four columns. This button (along with the "DOWN HANDLE") must be pressed and held during the entire lowering procedure

- "DOWN HANDLE" on powerpack pump manifold lowers the lift. Note: Before lowering the lift you should raise it slightly to remove pressure from safety locks allowing them to disengage completely.

**Note:** *Always lock both slip plates and turnplates following alignment adjustments and before removing vehicle from the lift.*



Typical Label Drawings  
Reprinted with permission from SAE J2184  
©2000 Society of Automotive Engineers, Inc.

## **PRE-OPERATION CHECK LIST**

### **Trained Lift Operator**

- ✓ All lift operators must be fully trained and qualified to safely and effectively operate the lift described and covered in this manual.

### **Absence of All Obstructions**

- ✓ The total work area must be free of any and all obstructions and be generally clean of oil and debris.

### **Visual Inspections**

- ✓ Every lift operator must thoroughly inspect the lift noting any problem area. An inspection of the floor area and anchor bolts must also be completed. Report any questionable item.

### **"No Load" Performance Check**

- ✓ All mechanical safety locks are operating properly and consistently
- ✓ No External Fluid Leaks
- ✓ No Lift "Bleed Down".
- ✓ Effortless and Simultaneous Movement
- ✓ Level Lifting
- ✓ All Controls Function Properly
- ✓ Safety Mechanisms all functional

### **Previous Operator's Report**

- ✓ Verify with previous operator and/or supervisor that there is no problem with the lift. If problems have been reported, insure all necessary repairs have been completed.

## **LIFT OPERATION**

### **Lift Operation**

- ✓ Perform pre-operation check list item by item
- ✓ Ensure lift is completely lowered
- ✓ Position vehicle on the lift

### **Caution**

- ✓ Avoid sudden "starts and stops" during loading and unloading of vehicle

### **To Raise the Lift**

- ✓ Turn switch on the electrical control box to the "ON" position
- ✓ Raise vehicle to desired working height
- ✓ Depress "DOWN" handle to lower lift on to the mechanical safeties

### **To Lower the Lift**

- ✓ Inspect the lifting area to insure all personnel and debris have been cleared away
- ✓ Raise the lift slightly and disengage all safety locks. Turn switch on electrical control box to the "OFF" position
- ✓ Hold down both the air valve and "DOWN" handle. Lower lift completely to the floor

## **MAINTENANCE INSTRUCTIONS**

**LIFT MAINTENANCE** : The following is a minimum maintenance schedule:

**DAILY**: - Raise and lower the lift (with no vehicle) at the beginning of each shift to verify the runways are level, safety locks are engaging, and the lift is operating properly.  
- Check all hydraulic fittings and lines for damage and leaks. Check electrical wiring for damage. Check all moving parts for uneven or excessive wear. Repair or replace all damaged, worn, or broken components immediately.  
- Clean all debris from the base frame area  
- Remove oil/grease on runways and rolling jack lift pads.

**WEEKLY**: - Check hydraulic fluid in reservoir and top up if required.  
- Check cables, cable pulleys and lifting cylinder.

**MONTHLY**: - Check that all anchor bolts are torqued to 75 ft-lbs (102Nm).  
- Clean and lubricate moving parts.

**EVERY YEAR**: - Have a certified lift technician inspect and certify all aspects of the lift as per "Automotive Lift Operation, Inspection and Maintenance" (ALOIM) guidelines.

**EVERY TWO YEARS**: - Change and replace hydraulic oil in cylinders and powerpack reservoir.

**Lubrication Specifications**: - where grease is required use a multi-purpose lithium grease  
- where lubricating oil is required use a SAE 30 oil  
- where hydraulic oil is required use ISO 32 hydraulic oil (10W non detergent )

### **The following criteria will determine when a lifting cable is no longer acceptable for service:**

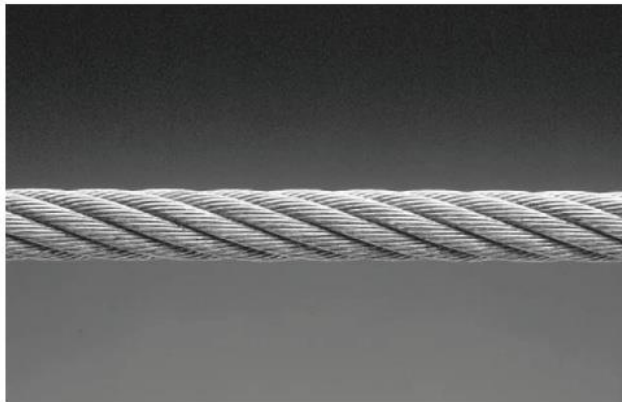
- 12 randomly distributed broken wires in one lay or four broken wires in one strand in one lay in running ropes
- one outer wire broken at the contact point with the core of the rope, which has worked its way out of the rope structure and protrudes or loops out from the rope structure
- wear of one-third the original diameter of outside individual wires
- kinking, crushing, birdcaging, or any other damage resulting in distortion of the rope structure
- evidence of heat damage from any cause
- reduction from nominal diameter greater than those listed in the following table:

**Lifting Cable Criteria continued on page 15**

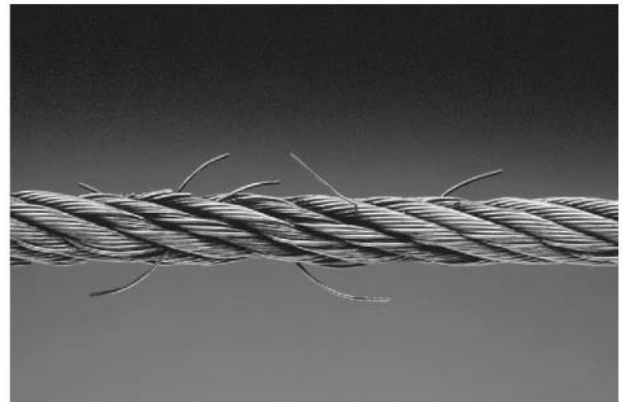
<b>Rope Diameter (inch)</b>	<b>Maximum allowable reduction from Nominal Diameter (inch)</b>
Less than or equal to 5/16	1/64
More than 5/16	1/32
More than 1/2 to	3/64

**Note:** Attention shall be given to end connections. Upon development of two broken wires adjacent to socket end connections, the rope shall be resocketed or replaced. Resocketing shall not be attempted if the resulting rope length will be insufficient for proper operation.

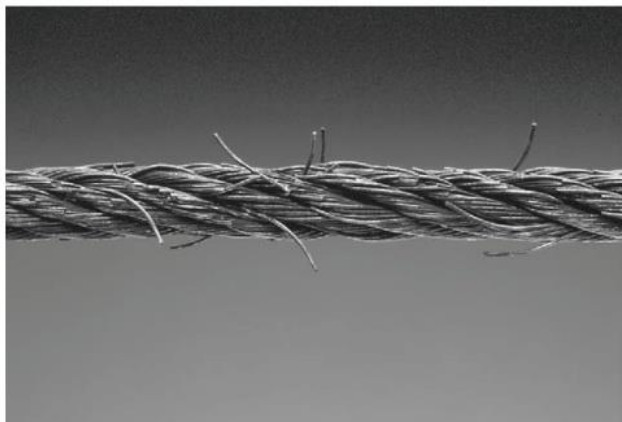
If any of the cable is as shown in the following pictures, do not use.



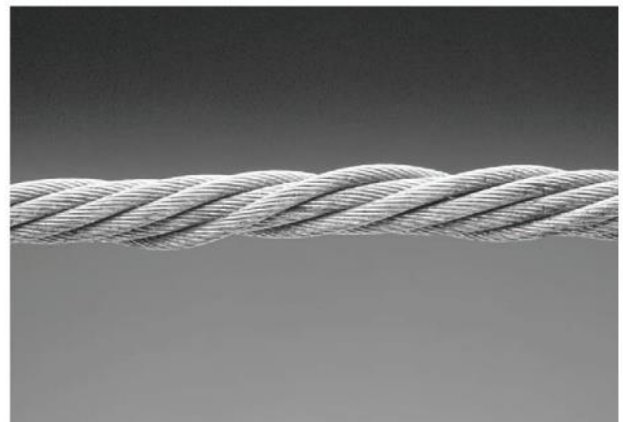
Typical Good Cable



Cable With Broken Wires



Cable With Severe Corrosion



Cable With Necking



## **TROUBLESHOOTING GUIDE**

The following are suggestions to consider if you have problems with the lift. Please call a qualified lift technician and/or a qualified electrician for further clarification and information.

Problem	Possible Cause	Solution
Lift Will Not Raise or Lower	<ol style="list-style-type: none"> <li>1. Blown fuse or circuit breaker</li> <li>2. Tripped thermal overload</li> <li>3. Incorrect voltage to motor</li> <li>4. Bad wiring connections</li> <li>5. "UP" switch burned out</li> <li>6. Motor windings burned out</li> </ol>	<ol style="list-style-type: none"> <li>1. Replace fuse or reset/replace circuit breaker</li> <li>2. Reset thermal overload</li> <li>3. Supply correct voltage to motor</li> <li>4. Repair and insulate all connections</li> <li>5. Replace switch</li> <li>6. Replace motor</li> </ol>
Lift Will Not Raise	<ol style="list-style-type: none"> <li>1. Air in oil or low oil level</li> <li>2. Lowering Valve leaks</li> <li>3. Motor runs backward</li> <li>4. Pump damaged</li> <li>5. Pump will not prime</li> <li>6. Relief Valve leaks</li> <li>7. Voltage to motor incorrect</li> <li>8. Lift overloaded</li> </ol>	<ol style="list-style-type: none"> <li>1. Check fluid level, oil seal, bleed system</li> <li>2. Clean valve or replace</li> <li>3. Check for correct wiring</li> <li>4. Repair or replace pump</li> <li>5. Check fluid level and pick-up tube - replace pump</li> <li>6. Clean Relief Valve (replace if necessary)</li> <li>7. Supply correct voltage to motor</li> <li>8. Verify that loaded vehicle weight does not exceed rated lift capacity</li> </ol>
Lift Will Not Lower	<ol style="list-style-type: none"> <li>1. Mechanical locks are engaged</li> <li>2. Obstruction under lift or in glide block tracks</li> <li>3. Faulty lowering solenoid valve</li> <li>4. No air pressure in air solenoid</li> </ol>	<ol style="list-style-type: none"> <li>1. Raise unit slightly and disengage mechanical locks</li> <li>2. Carefully remove obstruction - clean glide block tracks</li> <li>3. Replace valve</li> <li>4. Confirm airline is connected and has required pressure</li> </ol>
Lift Will Not Hold Pressure	<ol style="list-style-type: none"> <li>1. Contamination in system</li> <li>2. Internal Cylinder leaks</li> <li>3. Lowering Valve leaks</li> <li>4. Check Valve leaks</li> <li>5. External leaks</li> </ol>	<ol style="list-style-type: none"> <li>1. Check oil level - bleed cylinders - remove contamination - replace oil seal</li> <li>2. Check fitting, replace cylinder</li> <li>3. Contaminated fluid, handle binds, clean valves</li> <li>4. Clean check valve (replace if necessary)</li> <li>5. Check all fittings and repair leaks</li> </ol>

Problem	Possible Cause	Solution
Lift Will Not Raise A Vehicle	<ol style="list-style-type: none"> <li>1. Low hydraulic fluid</li> <li>2. Malfunction of pressure relief valve</li> <li>3. Insufficient electrical voltage</li> <li>4. Lift overload</li> <li>5. Motor is running backwards</li> <li>6. Air in hydraulic oil</li> <li>7. Pump will not prime</li> <li>8. Pump is damaged</li> <li>9. Faulty lowering valve</li> </ol>	<ol style="list-style-type: none"> <li>1. Lower lift. Using ISO grade 32 hydraulic oil, fill the powerpack reservoir to 1" below the top</li> <li>2. Clean pressure relief valve. If problem continues, call a service technician</li> <li>3. Confirm a 208/230 volt power supply to the lift</li> <li>4. Check that vehicle weight is evenly distributed and does not exceed 19,000 lbs. (8618 kg)</li> <li>5. Confirm proper motor rotation - rewire if required</li> <li>6. Check oil seal and bleed hydraulic system</li> <li>7. Check hydraulic oil level and pick-up tube. Replace pump if required</li> <li>8. Repair or replace pump</li> <li>9. Clean or replace valve</li> </ol>
Slow Drift Down	<ol style="list-style-type: none"> <li>1. Mechanical safety locks not engaged</li> <li>2. Powerpack lowering valve contamination</li> <li>3. Hydraulic system leaks</li> </ol>	<ol style="list-style-type: none"> <li>1. Raise lift to engage all safety locks then lower lift and confirm all safety locks are engaged</li> <li>2. Back flush powerpack by opening manual over-right valve. Engage "up" switch and down lever at the same time and run approximately 10 seconds</li> <li>3. Check cylinder and all fittings for any hydraulic oil leak</li> </ol>
Lift Going Up Out of Level	<ol style="list-style-type: none"> <li>1. Lift installed on un-level floor</li> <li>2. Cable(s) out of adjustment</li> </ol>	<ol style="list-style-type: none"> <li>1. Reinstall on level surface</li> <li>2. Adjust cable tension - see installation #31 and refer to diagram #4. Call service technician if problem persists</li> </ol>
Locking Mechanisms Do Not Engage / Disengage	<ol style="list-style-type: none"> <li>1. Safeties are binding</li> <li>2. Faulty air cylinder</li> <li>3. Damaged air line</li> <li>4. Safety locks do not latch properly</li> <li>5. Safety locks do not disengage</li> </ol>	<ol style="list-style-type: none"> <li>1. Lubricate mechanism</li> <li>2. Replace air cylinder</li> <li>3. Repair/replace air line</li> <li>4. Adjust mechanisms per lift installation instructions</li> <li>5. Check air supply and air cylinder – replace if required. Reset electronic circuit by pressing "Emergency Stop Button" for 15 seconds and then release it. Call service technician</li> </ol>
Anchors Will Not Stay Tight	<ol style="list-style-type: none"> <li>1. Holes drilled oversize</li> <li>2. Concrete floor thickness or holding strength not sufficient</li> </ol>	<ol style="list-style-type: none"> <li>1. Relocate lift using the correct bit to drill holes</li> <li>2. Break out old concrete and re-pour new foundation per lift installation instruction</li> </ol>

**Replace all worn or broken parts and components only with manufacturer approved/supplied parts and components**

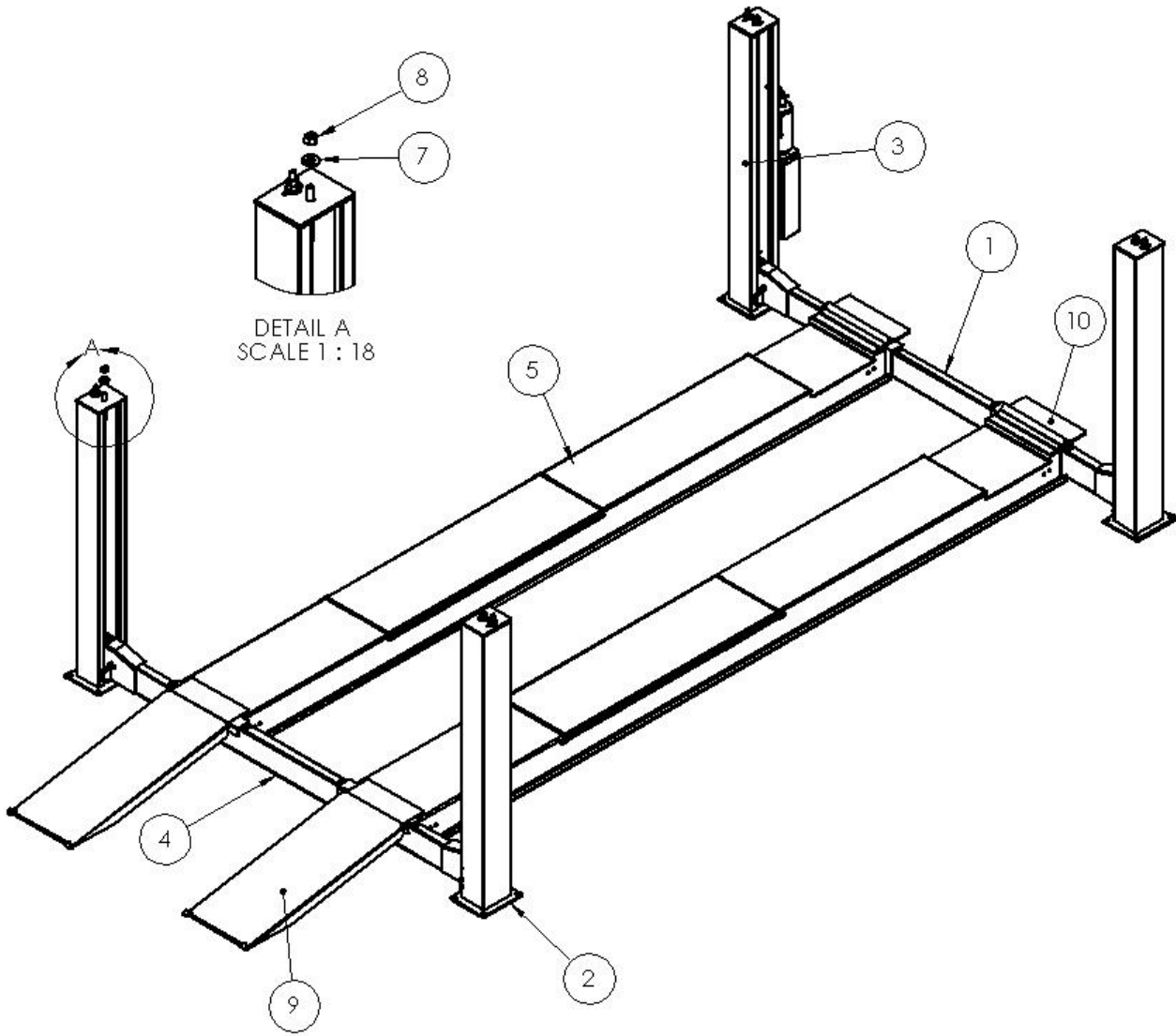
**Replacement parts may be purchased from your local lift supplier or the manufacturer at 1 - 877 - 799 - LIFT (5438) or (905) 847 – 1198**

## **LIFT ILLUSTRATIONS and PARTS LISTS**

The diagrams listed below, along with related parts lists, will assist you when installing and servicing this lift. Please ensure these lift diagrams and parts lists are kept in a secure place for quick reference.

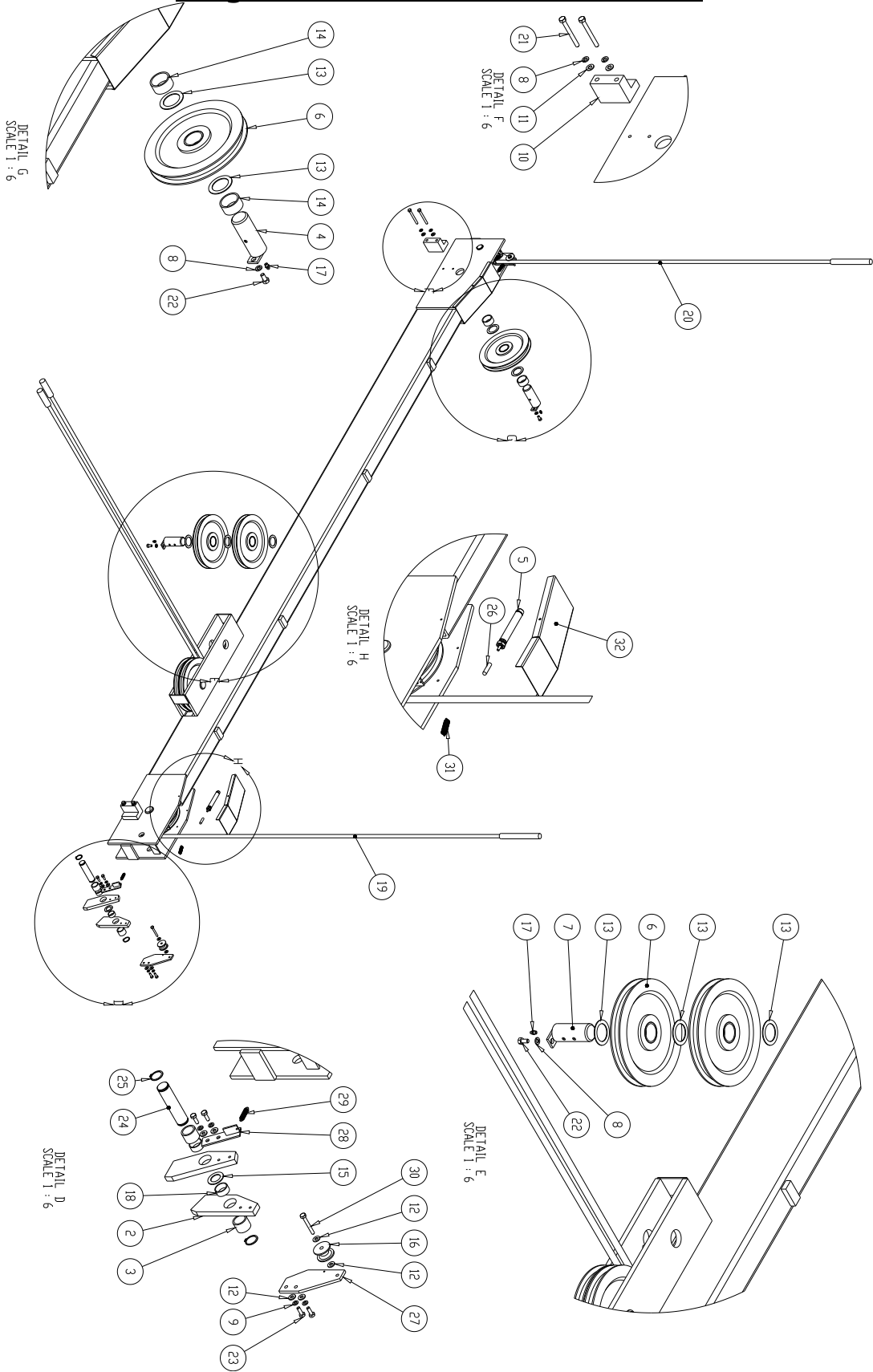
Diagram #1 - Lift Assembly	page 20
Diagram #2 - Rear Cross Member	page 21
Diagram #3 - Front Cross Member	page 23
Diagram #4 - Secondary Tower Assembly	page 25
Diagram #5 - Powerpack Tower Assembly	page 26
Diagram #6 - Lifting (Equalizing) Cable Routing	page 27
Diagram #7 - Anchor Bolt Installation	page 28
Diagram #8 - Driver (left) Side Runway Assembly	page 29
Diagram #9 - Passenger (right) Side Runway Assembly	page 31
Diagram #10 - Pneumatic Controls	page 32
Diagram #11 - Wheel Stop Assembly	page 33
Diagram #12 - Ramp Assembly	page 33
Diagram #13 - Safety Instruction	page 34
Diagram #14 - Wiring Diagram	page 35

## Diagram #1: LIFT ASSEMBLY



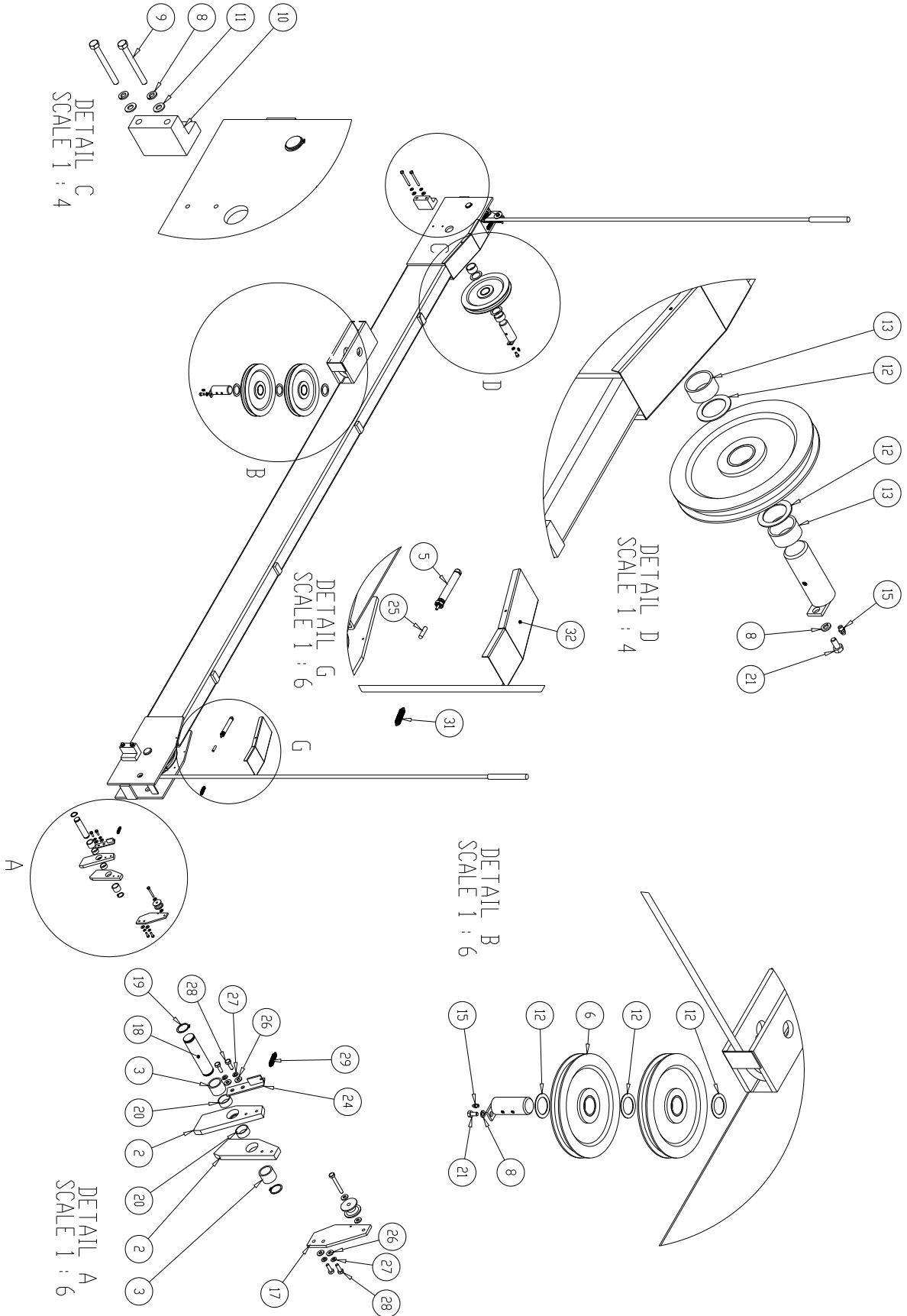
ITEM NO.	PART NUMBER	DESCRIPTION	QTY.
1	44180003	CROSSMEMBER ASSY FRONT	1
2	44180001	TOWER ASSY	3
3	44180001	TOWER ASSY (POWER)	1
4	44180002	CROSSMEMBER ASSY REAR	1
5	44180005	DECK ASSY DRIVER SIDE	1
6	44180006	DECK ASSY PASSENGER SIDE	1
7	3C000046	7/8" WIDE WASHER	4
8	3C000047	HHNUT 0.875-14-B-N	4
9	41140014	PIVOTING RAMP ASSEMBLY	2
10	44180012	WHEELSTOP ASSY	2

# Diagram #2: REAR CROSSMEMBER



ITEM NO.	PART NUMBER	DESCRIPTION	QTY.
1	24180002	CROSSMEMBER WELDMENT BACK	1
2	14180018	SAFETY LOCK	4
3	14180030	SAFETY SPACER	4
4	24180009	VERT PULLEY PIN WELDMENT	2
5	21.375	BIMBA CYLINDER	2
6	44180010	PULLEY 12/14/18k C/W BUSHING	6
7	24180004	PIN WELDMENT	2
8	3C000000	5/16 SPRING LOCK WASHER	12
9	3C000044	1/4 SPRING LOCK WASHER	8
10	14180049	SLIDER BLOCK	4
11	3C000023	5/16 REGULAR WASHER	8
12	3C000043	1/4 REGULAR WASHER	12
13	14180050	SPAENAUER SHIM 1.5ID 2.125OD 0.062TH	10
14	14180053	SPACER	4
15	14180054	WASHER	2
16	44180007	BACK-UP LATCH ROLLER W/ BEARINGS	2
17	31140013	GREASE FITTING 1/4-20 UNC	4
18	14180035	DU BUSHING 16DU08	4
19	14180062	CABLE 1 (188" LENGTH, 3-3/4 BUTTON))	1
20	14180063	CABLE 2 (251" LENGTH, 3-3/4 BUTTON)	1
21	3C000039	HBOLT 0.3125-18x3X0.875-N-GR5	8
22	3C000040	HBOLT 0.3125-18x0.625x0.625-N-GR5	4
23	3C000045	HBOLT 0.25-20x0.75x0.75-N-GR5	8
24	14180087	SAFETIES PIN	2
25	3C000053	Basic External Retaining Ring	4
26	14180031	AIR CYLINDER TAPPET	2
27	14180060	ROLLER/COUNTERWEIGHT HOLDER	2
28	24180012	LEVER WELDMENT	2
29	14180078	SPRING	2
30	3C000048	HBOLT 0.25-20x2x0.75-N-GR5	2
31	14180089	SPRING	2
32	14180088	SHEAVE COVER	2

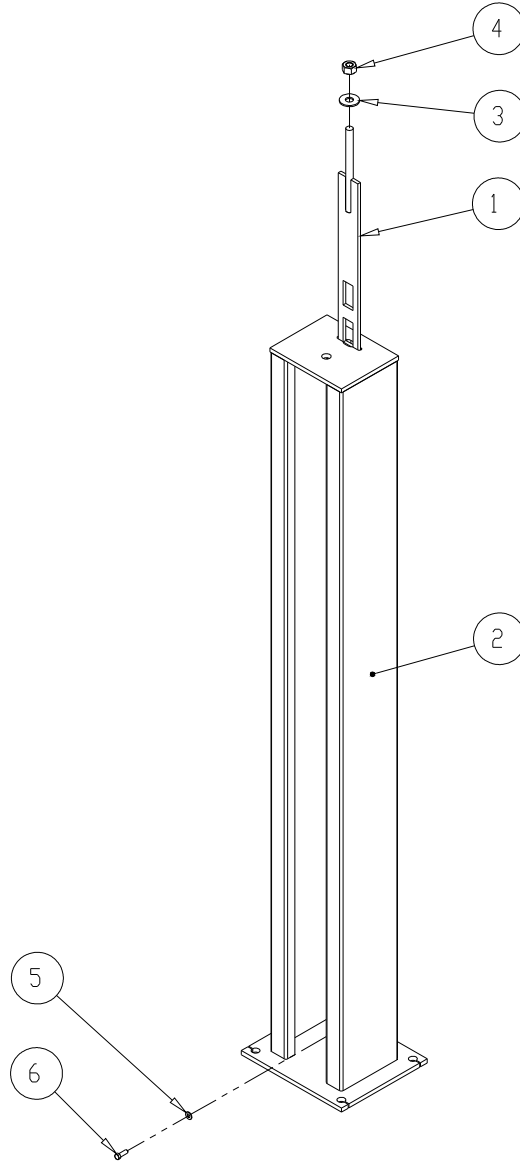
# Diagram #3: FRONT CROSSMEMBER



ITEM NO.	PART NUMBER	DESCRIPTION	QTY.
1	24180003	CROSSBEAM WELDMENT FRONT	1
2	14180018	SAFETY LOCK	4
3	14180030	SAFETY SPACER	4
4	24180009	VERT PULLEY PIN WELDMENT	2
5	21.375	BIMBA CYLINDER	2
6	44180010	PULLEY 12/14/18k C/W BUSHING	4
7	24180004	PIN WELDMENT	1
8	3C000000	5/16 SPRING LOCK WASHER	11
9	3C000039	HBOLT 0.3125-18x330.875-N-GR5	8
10	14180049	SLIDER BLOCK	4
11	3C000023	5/16 REGULAR WASHER	8
12	14180050	SPAENAU SHIM 1.5ID 2.125OD 0.062TH	7
13	14180053	SPACER	4
14	14180054	WASHER	2
15	31140013	GREASE FITTING 1/4-20 UNC	3
16	44180007	BACK-UP LATCH ROLLER W/ BEARINGS	2
17	14180060	ROLLER/COUNTERWEIGHT HOLDER	2
18	14180087	SAFETIES PIN	2
19	3C000053	Basic External Retaining Ring	4
20	14180035	DU BUSHING 16DU08	4
21	3C000040	HBOLT 0.3125-18x0.625x0.625-N-GR5	3
22	14180065	CABLE 4 (432" LENGTH, 3-3/4 BUTTON)	1
23	14180064	CABLE 3 (495" LENGTH, 3-3/4 BUTTON)	1
24	24180012	LEVER WELDMENT	2
25	14180031	AIR CYLINDER TAPPET	2
26	3C000043	1/4 REGULAR WASHER	12
27	3C000044	1/4 SPRING LOCK WASHER	8
28	3C000045	HBOLT 0.25-20x0.75x0.75-N-GR5	8
29	14180078	SPRING	2
30	3C000048	HBOLT 0.25-20x2x0.75-N-GR5	2
31	14180089	SPRING	2
32	14180088	SHEAVE COVER	2

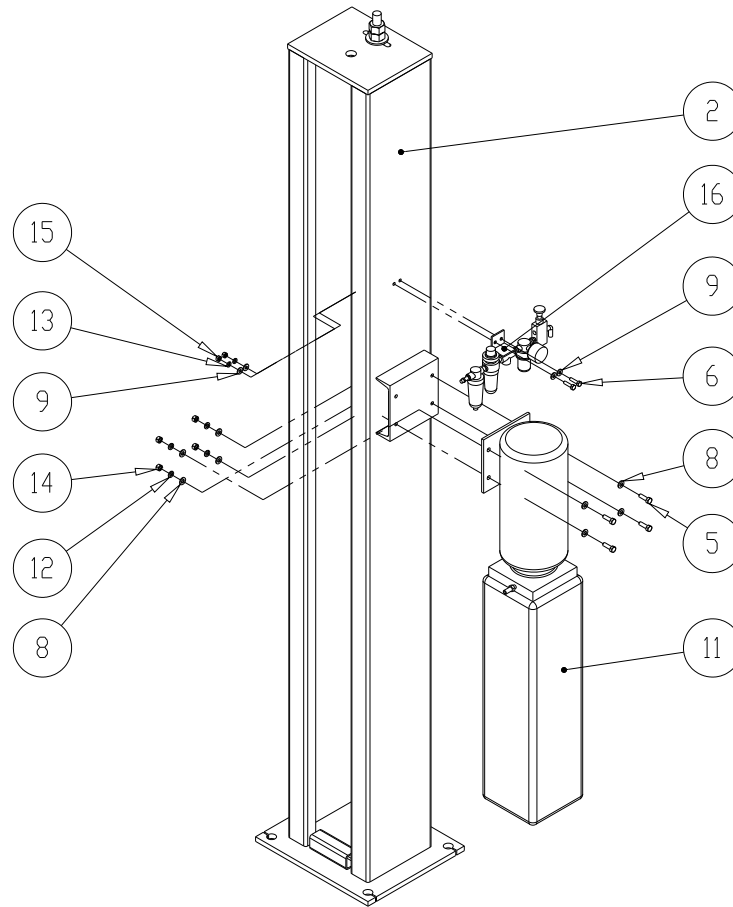


## Diagram #4: Tower Assembly



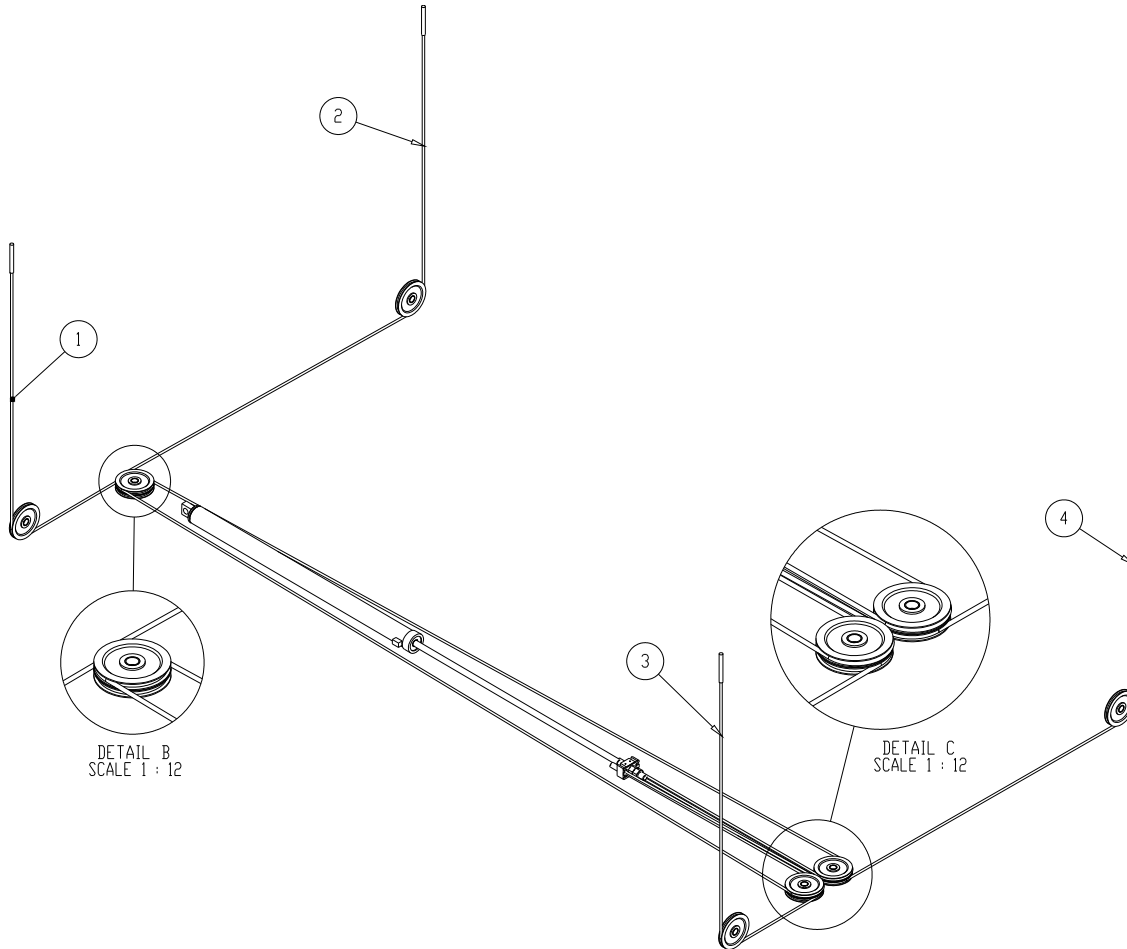
ITEM NO.	PART NUMBER	DESCRIPTION	QTY.
1	24180001	SAFETY LADDER WELDMENT	1
2	24180000	TOWER WELDMENT	1
3	3C000035	3/4" WIDE WASHER	1
4	3C000036	HHNUT 0.75-10-B-N	2
5	3C000037	3/8 REGULAR WASHER	1
6	3C000038	HBOLT 0.375-16x1.125x1.125-N-GR5	1

## Diagram #5: Power pack Tower Assembly



ITEM NO.	PART NUMBER	DESCRIPTION	QTY.
1	24180001	SAFETY LADDER WELDMENT	1
2	24180000	TOWER WELDMENT	1
3	3C000036	HHNUT 0.75-10-B-N	2
4	3C000038	HBOLT 0.375-16x1.125x1.125-N-GR5	1
5	3C000021	HBOLT 0.3125-18x1x1-N-GR5	4
6	3C000051	HBOLT 0.25-20x1x1-N-GR5	2
7	3C000037	3/8 REGULAR WASHER	1
8	3C000023	5/16 REGULAR WASHER	8
9	3C000043	1/4 REGULAR WASHER	4
10	3C000035	3/4" WIDE WASHER	1
11	34180009	POWER PACK	1
12	3C000000	5/16 SPRING LOCK WASHER	4
13	3C000044	1/4 SPRING LOCK WASHER	2
14	3C000027	5/16-18 HEX NUT	4
15	3C000052	1/4-20 HEX NUT	2
16	44180011	PNEUMATIC CONTROLS	1

## **Diagram #6: Lifting (Equalizing) Cable Routing**



### **Standard Model (202" Deck)**

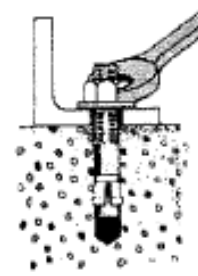
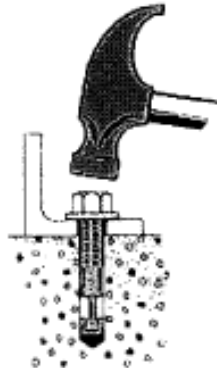
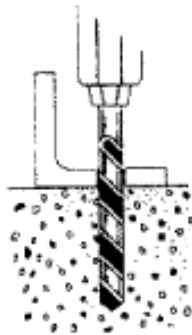
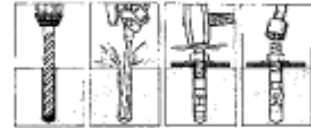
ITEM NO.	PART NUMBER	DESCRIPTION	QTY.
1	34180025	CABLE 1 (376" LENGTH, 3-3/4 BUTTON)	1
2	34180026	CABLE 2 (439" LENGTH, 3-3/4 BUTTON)	1
3	34180027	CABLE 3 (160" LENGTH, 3-3/4 BUTTON)	1
4	34180028	CABLE 4 (223" LENGTH, 3-3/4 BUTTON)	1

### **Extended Model (230" Deck)**

ITEM NO.	PART NUMBER	DESCRIPTION	QTY.
1	34180024	CABLE 1 (432" LENGTH, 3-3/4 BUTTON)	1
2	34180023	CABLE 2 (495" LENGTH, 3-3/4 BUTTON)	1
3	34180021	CABLE 3 (188" LENGTH, 3-3/4 BUTTON)	1
4	34180022	CABLE 4 (251" LENGTH, 3-3/4 BUTTON)	1

## Diagram #7: Anchor Bolt Installation

### Wedge Anchor Installation



**1.**  
Drill hole in concrete (hole diameter same as thread diameter) maximum depth of hole could be any depth beyond minimum recommended depth. Clean the hole with compressed air.

**2.**  
Drive wedge anchor into drilled hole through fixture so that nuts is flush with fixture

**3.**  
Tighten nut until wrench resistance is felt (approximately 3 to 4 turns of the nut after first resistance) anchorage is now complete

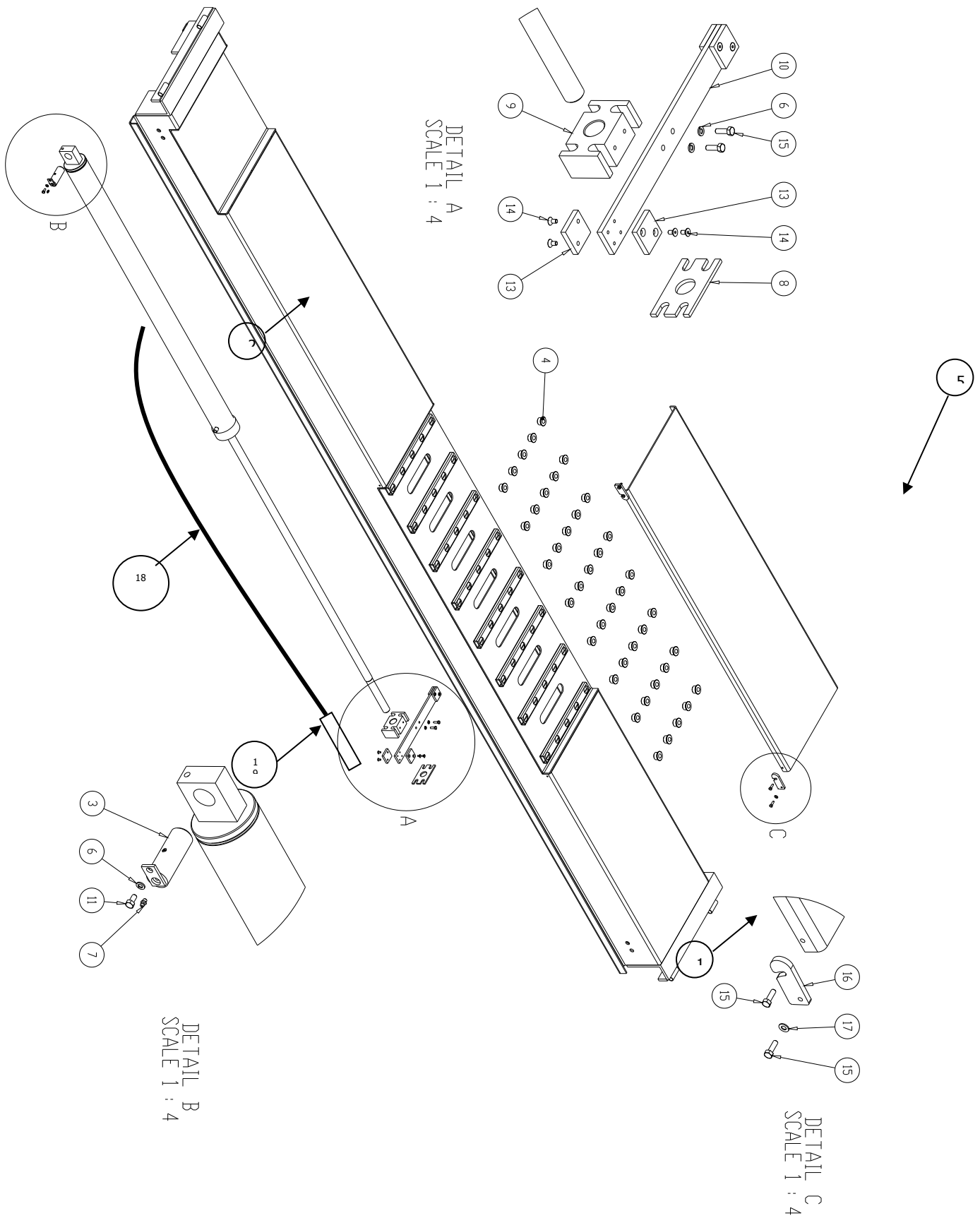
#### MORE HELPFUL INSTRUCTIONS

1. Always wear safety glasses.
2. Follow the drill manufacturer's safety instructions.
3. Use only solid carbide-tipped bits meeting the ANSI B94-12 tip diameter as shown below in bottom Table.
4. Drill the hole perpendicular to the work surface. To assure full holding power, do not ream the hole or allow the drill to wobble.
5. Drill the hole as deep as the full length of the anchor, but not close then two anchor diameters to the bottom (opposite surface of the concrete)
6. Clean the hole using compressed air and a wire brush. A clean hole is necessary for proper performance.
7. Assemble the washer and nut on the anchor so the nut is recessed slightly below the head of the anchor.
8. Tap the anchor through the fixture (must be 1/8" larger then diameter of the anchor) and into the hole making sure the nut and washer rest solidly against the fixture or tap the anchor into the hole and then place bracket over the anchor.
9. Tighten the nut with a torque wrench to proper torque according to the table
10. If spinning occurs, pull up on the anchor using the claw end of a hammer and then torque.

DRILL TOLERANCE – ANSI B-94-12 AND TORQUE REQUIREMENT			
Anchor Diameter	Minimum	Maximum	Torque Range
¼"	.260"	.268"	5-10ft-lbs
3/8"	.390"	.398"	25-30ft-lbs
½"	.520"	.530"	50-60ft-lbs
5/8"	.650"	.660"	75-90ft-lbs
¾"	.775"	.787"	150-175ft-lbs
7/8"	.905"	.917"	200-250ft-lbs
1"	1.030"	1.042"	250-300ft-lbs
1 ¼"	1.285"	1.300"	400-450ft-lbs

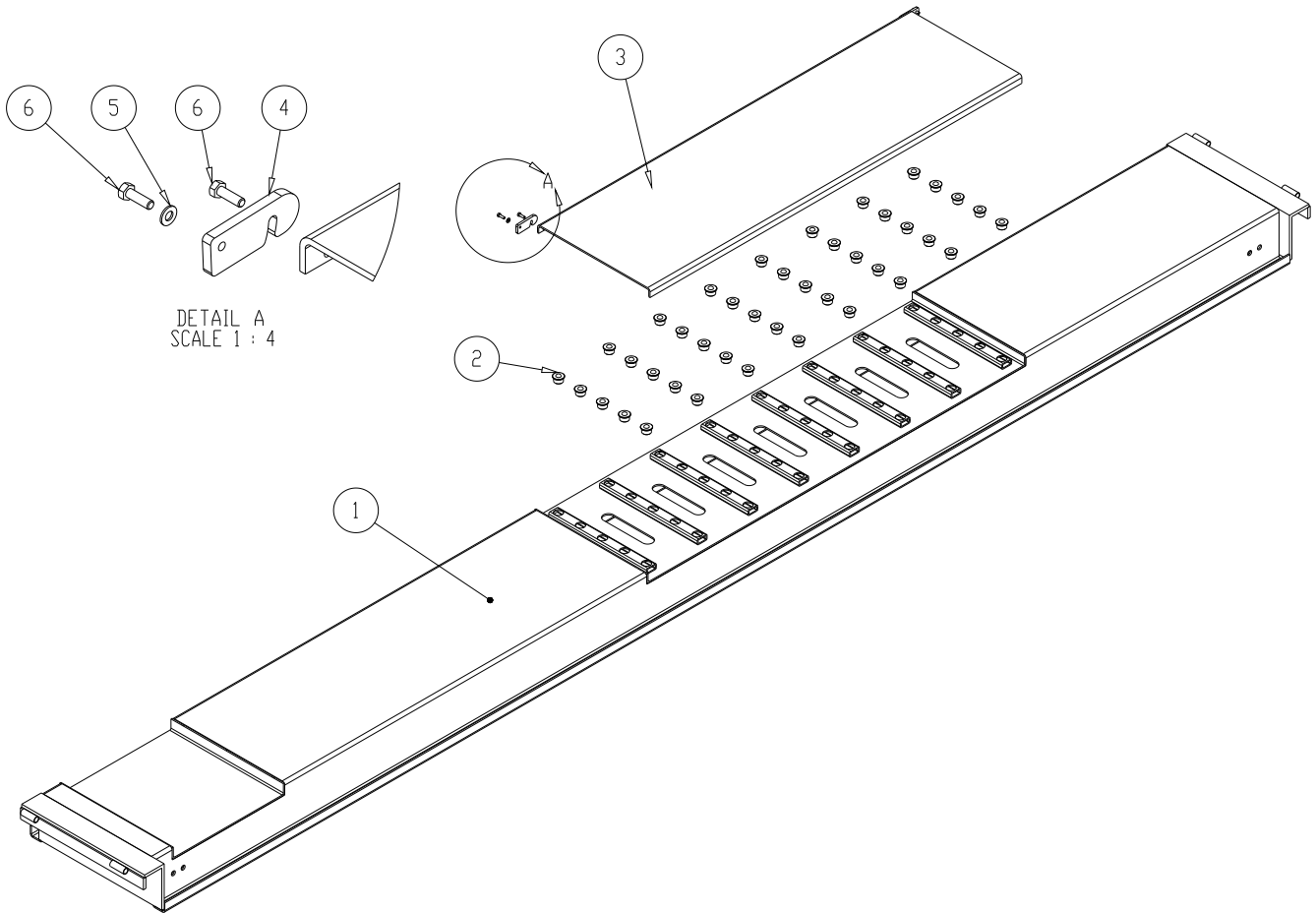
Wedge-All Dia (in)	1/4	3/8	1/2	5/8	3/4	7/8	1	1 1/4	1 1/2
Bit Size (in)	1/4	3/8	1/2	5/8	3/4	7/8	1	1 1/4	1 1/2
Fixture Hole (in)	5/16	7/16	9/16	11/16	7/8	1	1 1/8	1 3/8	1 5/8
Wrench Size (in)	7/16	9/16	3/4	15/16	1 1/8	1 5/16	1 1/2	1 7/8	2 1/4

# Diagram #8: Driver (left) Side Runway Assembly



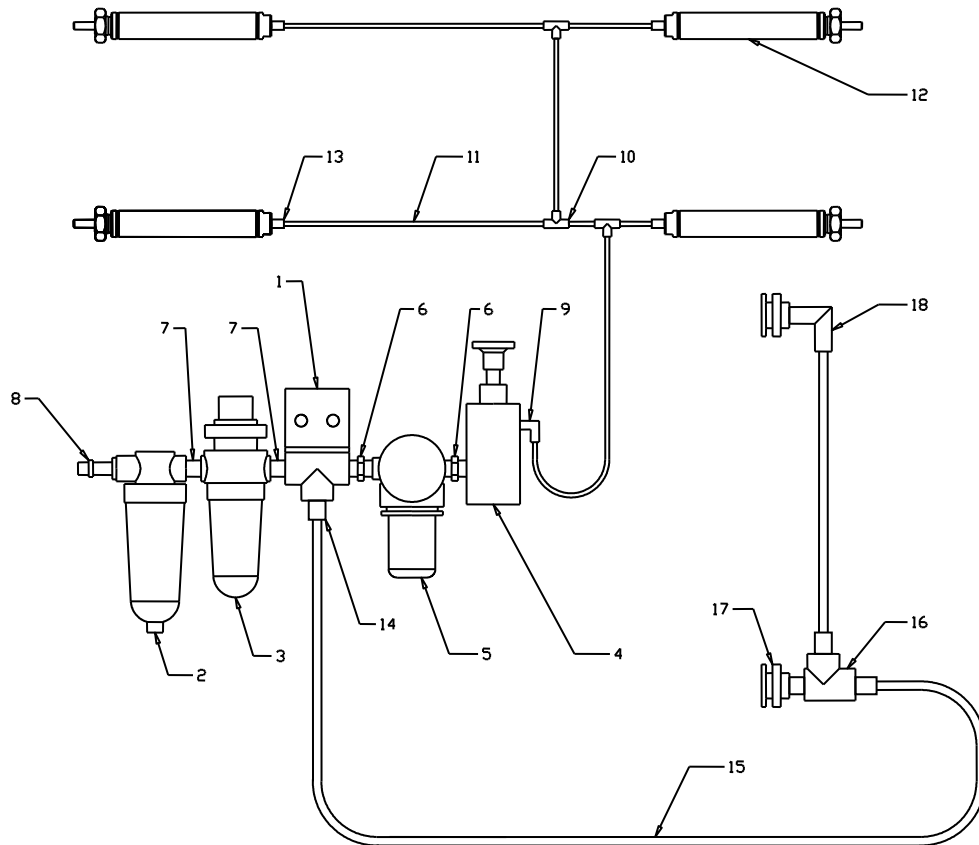
ITEM NO.	PART NUMBER	DESCRIPTION	QTY.
1	24180005	DECK WELDMENT DRIVER SIDE	1
2	44180004	CYLINDER ASSY	1
3	24180009	VERT PULLEY PIN WELDMENT	1
4	31140005	7/8" BALL TRANSFER PATT 522	40
5	21140023	FLOATING DECK COVER WELDMENT	1
6	3C000000	5/16 SPRING LOCK WASHER	3
7	31140013	GREASE FITTING 1/4-20 UNC	1
8	14180067	TRUNNION SAFETY PLATE	1
9	14180068	TROGNON	1
10	14180069	TRUNNION GUIDING PLATE	1
11	3C000040	HBOLT 0.3125-18x0.625x0.625-N-GR5	1
12	3C000043	HHNUT 1.375-12-B-N	2
13	14180076	TRUNNION GUIDE BLOCK	4
14	3C000015	Socket Countersunk Head Cap screw	8
15	3C000021	HBOLT 0.3125-18x1x1-N-GR5	6
16	11140002	SLIP PLATE LOCK	2
17	3C000023	5/16 REGULAR WASHER	2
18	34185010	HYDRAULIC HOSE	1
19	34185011	STRAIGHT FITTING (TO CYLINDER)	1

## **Diagram #9: Passenger (right) Side Runway Assembly**



ITEM NO.	PART NUMBER	DESCRIPTION	QTY.
1	24180008	DECK WELDMENT PASSENGER SIDE	1
2	31140005	7/8" BALL TRANSFER PATT 522	40
3	21140023	FLOATING DECK COVER WELDMENT	1
4	11140002	SLIP PLATE LOCK	2
5	3C000023	5/16 REGULAR WASHER	2
6	3C000021	HBOLT 0.3125-18x1x1-N-GR5	4

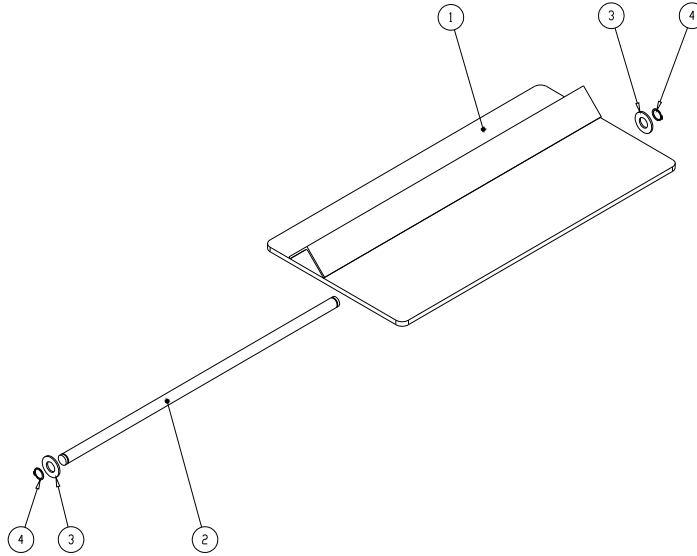
## Diagram #10: Pneumatic Controls



ITEM NO.	PART NO.	DESCRIPTION	QTY.
1	24180013	PNUEMATIC CONTROLS WELDMENT	1
2	34180013	FILTER	1
3	34180012	LUBRICATER	1
4	34180011	VALVE	1
5	34180010	REGULATOR	1
6	34180015	FITTING	2
7	34180016	FITTING	2
8	34180017	AIR INTAKE FITTING	1
9	31140119	ELBOW 5/32" POLY – 1/8" NPT	1
10	31141063	TEE FITTING	3
11	31140120	POLYTUBE 5/32" DIA. BLUE	46'
12	34180000	AIR CYLINDER	4
13	31140122	STRAIGHT 5/32" POLY - 1/8" NPT	4
14	31141062	POLY FITTING 3/8" x 1/4" NPT STRAIGHT	3
15	31141056	POLYTUBE 3/8" DIA. BLUE	40'
16	31141061	BRASS FORGED STEEL TEE	1
17	31141060	TERMINAL BOLT (STEEL)	2
18	31140023	Poly Elbow swivel 3/8" x 1/4" NPT	1

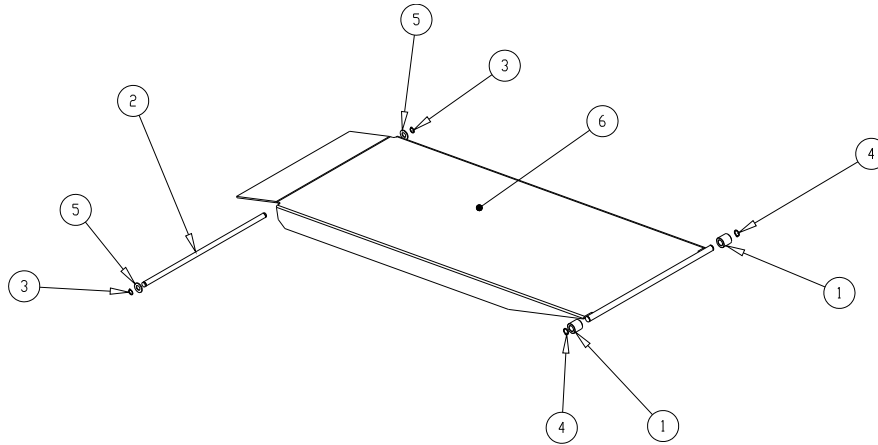


**Diagram #11: Wheel Stop Assembly**



ITEM NO.	PART NUMBER	DESCRIPTION	QTY.
1	24180014	WHEELSTOP WELDMENT	1
2	11140128	PIVOTING PIN	1
3	3C000030	5/8 REGULAR WASHER	2
4	3C000028	5/8 RETAINING RING	2

**Diagram #12: Ramp Assembly**

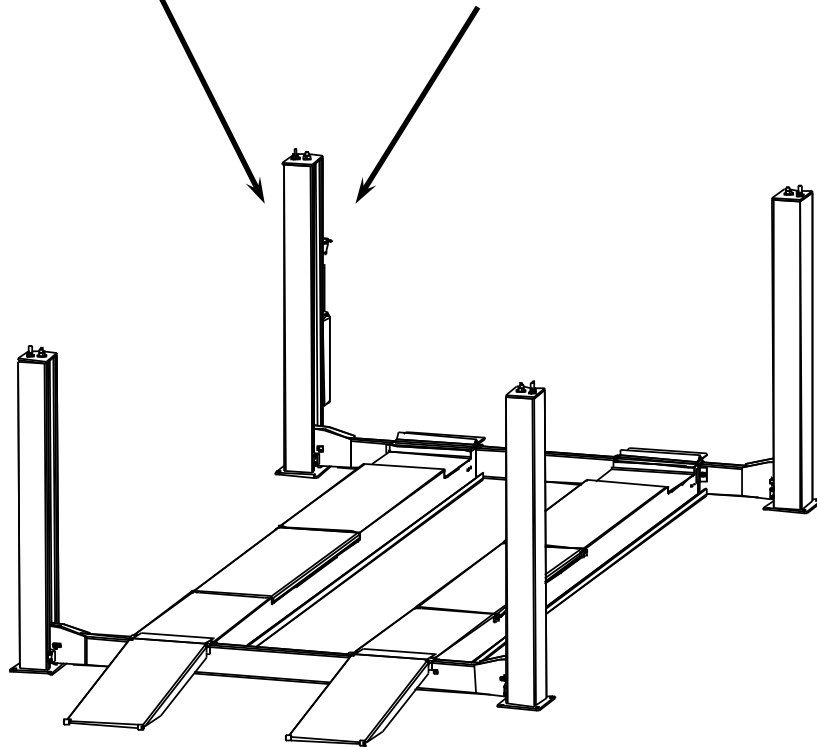


ITEM NO.	PART NUMBER	DESCRIPTION	QTY.
1	11140126	ROLLER	2
2	11140128	PIVOTING PIN	1
3	3C000028	5/8 RETAINING RING	2
4	3C000029	RETAINING RING	2
5	3C000030	5/8 REGULAR WASHER	2
6	21140100	RAMP WELDMENT	1

# Diagram #13: SAFETY INSTRUCTIONS

SAFETY INSTRUCTIONS	SAFETY INSTRUCTIONS
Read operating and safety manuals before using lift.	Proper maintenance and inspection is necessary for safe operation.
SAFETY INSTRUCTIONS	
Do not operate a damaged lift.	<p>The messages and pictographs shown are generic in nature and are meant to generally represent hazards common to all automotive lifts regardless of specific style.</p> <p>Funding for the development and validation of these labels was provided by the Automotive Lift Institute, PO Box 85 Cortland, NY 13045.</p> <p>Replacement label sets may be obtained from the original lift manufacturer and ALI's member companies. They are protected by copyright.</p> <p><a href="http://www.autolift.org">www.autolift.org</a>          © 1992 by ALI, Inc. ALIWL101s</p>

⚠ CAUTION	⚠ CAUTION	⚠ WARNING	⚠ WARNING
Lift to be used by trained operator only.	Authorized personnel only in lift area.	Clear area if vehicle is in danger of falling.	Position vehicle with center of gravity midway between adapters.
⚠ CAUTION	⚠ CAUTION	⚠ WARNING	⚠ WARNING
Use vehicle manufacturer's lift points.	Always use safety stands when removing or installing heavy components.	Remain clear of lift when raising or lowering vehicle.	Avoid excessive rocking of vehicle while on lift.
⚠ CAUTION	⚠ CAUTION	⚠ WARNING	⚠ WARNING
Use height extenders when necessary to ensure good contact.	Auxiliary adapters may reduce load capacity.	Do not override self-closing lift controls.	Keep feet clear of lift while lowering.
<p>The messages and pictographs shown are generic in nature and are meant to generally represent hazards common to all automotive lifts regardless of specific style.</p> <p>Funding for the development and validation of these labels was provided by the Automotive Lift Institute, PO Box 85 Cortland, NY 13045.</p> <p>Replacement label sets may be obtained from the original lift manufacturer and ALI's member companies. They are protected by copyright.</p> <p><a href="http://www.autolift.org">www.autolift.org</a> ©1992 by ALI, Inc. ALIWL101c</p>		<p>The messages and pictographs shown are generic in nature and are meant to generally represent hazards common to all automotive lifts regardless of specific style.</p> <p>Funding for the development and validation of these labels was provided by the Automotive Lift Institute, PO Box 85 Cortland, NY 13045.</p> <p>Replacement label sets may be obtained from the original lift manufacturer and ALI's member companies. They are protected by copyright.</p> <p><a href="http://www.autolift.org">www.autolift.org</a> ©1992 by ALI, Inc. ALIWL101e</p>	



**Diagram #14: POWER UNIT WIRING DIAGRAM**

