

coats

*Engineered to Perform.
Designed to Last.*



MAXX 80 TIRE CHANGER

BUILT ON THE BEST PLATFORM IN THE BUSINESS



MAXX RIM/CLAMP

The Coats® Maxx picks up where the X-Series left off but goes further. This unit has been completely redesigned from the ground up based on extensive customer R&D and represents what it takes to make it in the high-volume tire business.

- ✓ WIDER, MORE ROBUST CHASSIS
- ✓ MORE POWER, MORE FEATURES
- ✓ IMPROVED SPEED AND RELIABILITY



6" - 24" EXTERNAL CLAMPING DIAMETER



BOTH HAND AND FOOT CONTROL BEAD LOOSENER INCLUDED



220V 2HP AND 110V ELECTRIC OR AIR MOTOR



74"W X 86"H X 44"D

POWERFUL DYNAMIC FEATURES

DURABLE AND RELIABLE



More Robust Chassis

Tested up to 250,000 bead breaking cycles for ultimate durability in the harshest working environments.

BETTER BEAD SEALING

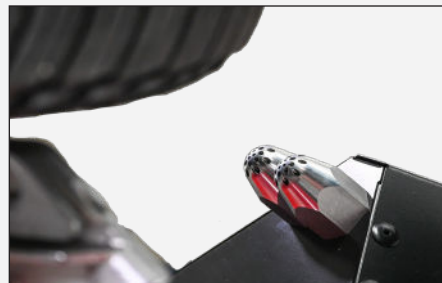

Dual Nozzle Bead Sealer

Seal difficult assemblies with ease with more air, more quickly.

TIME SAVER

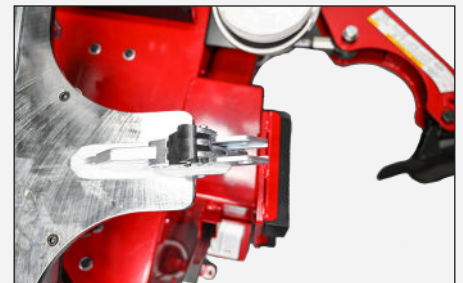

No-Index Tabletop

Save time by not having to index the tabletop when working on large assemblies, reducing pedal presses and allowing techs to keep moving.

BEAD LOOSENER CHOICE



Hand and Foot Operated Bead Loosener

Different technicians have different work styles. Giving them a choice (hand or foot) of how they do the work lets them get it done on their terms.

VERSATILE CLAMPING



Grip Max 2.0 Clamps

Clamp passenger car, light truck or extreme custom applications without changing anything for maximum time savings and damage avoidance.

POWER WHEN YOU NEED IT



220V 2HP Power Option

With high torque 220V 2HP motor you can power through tough assemblies.

PATENTED TOOL HEADS

Our patented tool heads work hard so you don't have to. The Maxx 80 features our Polymer Duckhead, Robo Roller and Robo Arm to make changing any tire a breeze.



CELEBRATING AND CONNECTING OUR MANUFACTURERS



ROBO ROLLER ARM

Device that provides additional power when mounting difficult tire assemblies and prevents the bead from rolling back over the mount tool.



ROBO ARM BEAD DEPRESSOR

Tool used to push the tire bead into the drop center of the rim, allowing for effortless mounting and dismounting of the tire.



POLYMER DUCKHEAD

Tool used for mounting and demounting tires without damaging the rim.



SCAN ME

SEE THE MAXX 80 IN ACTION

MOUNT & DEMOUNT TIRES WITHOUT DAMAGE

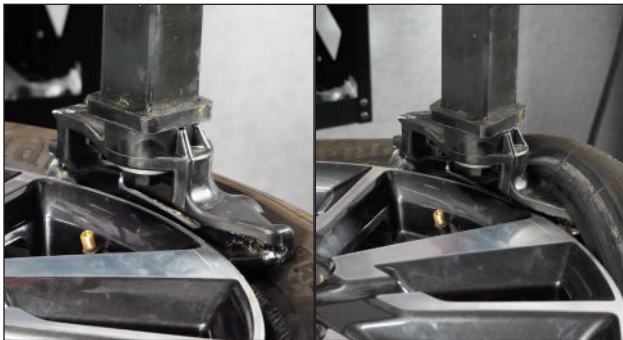

MAINTAIN DROP CENTER & LIFT HEAVY ASSEMBLIES



KEEP TOUGH BEADS IN DROP CENTER



SIMPLE CONTROLS MAKE IT EASY

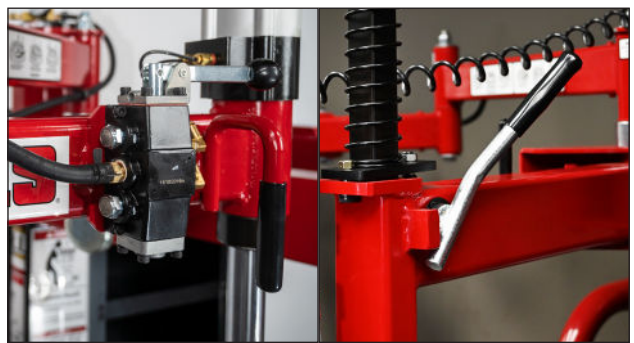

SHOP TYPES



HIGH VOLUME TIRE DEALERS
OR GENERAL REPAIR SHOPS

TIRE TYPES



- ✓ OE PASSENGER
- ✓ PICKUP TRUCK & SUV
- ✓ PERFORMANCE

- ✓ MEDIUM-DUTY TRUCK
- ✓ LOW PROFILE
- ✓ RUN-FLAT

POWER / TORQUE



COATS' STRONGEST, MOST
ROBUST RIM CLAMP TIRE
CHANGER

MAXX

SPEED + POWER + DURABILITY + RELIABILITY + CAPABILITY

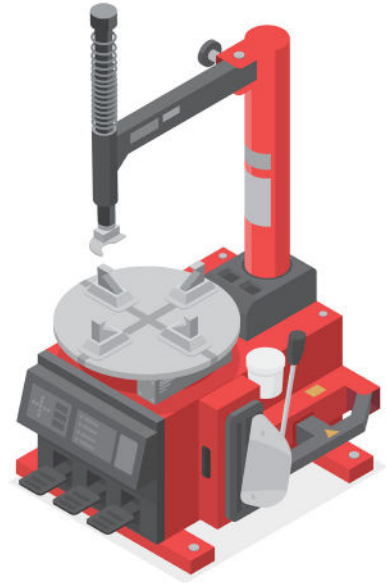

Maxx 80

"The Other Guys"

Machine Style	Tabletop Rim Clamp ✓	Tabletop Rim Clamp	
Mount/Demount Tool	Polymer, Steel, and Highspoke Duckhead ✓	Polymer Mount Head	✗
Capacity	6-30" External* (24" Total Range) ✓	10-26" External (16" Total Range)	✗
Max Width	16" ✓	14"	✗
Tire Max Diameter	50" ✓	43"	✗
Bead Loosening Type	Dual Mode Hand/Foot Shovel Control ✓	Push Button Hand Shovel Only	✗
Bead Loosener Width	Up to 22" Wide ✓	Only 16"	✗
Pressing Devices	Robo-Arm, RoboRoller, ✓	Disc Roller, Bead Press,	✗
Secondary Inflation	Double Single Point ✓	Optional Hose	✗
Motors	Electric: 2HP, 220V, 60 Hz Electric: 2-Speed, 220V, 60 Hz 10 & 22RPM CW, 10RPM CCW, Electric: 110V Air: 4.0 HP Air Motor, 110-175 psi, 15 scfm ✓	220V 1HP 7 & 17 RPM CW, 7 RPM CCW	✗
Power	220V or 110V ✓	220V	✗

*With optional Extended 30" Clamps

DUAL NOZZLE INFLATION SYSTEM

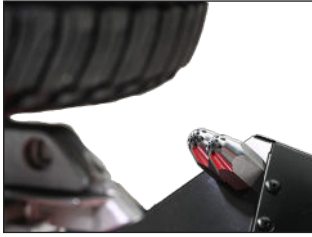

UP TO 16" WHEEL WIDTH

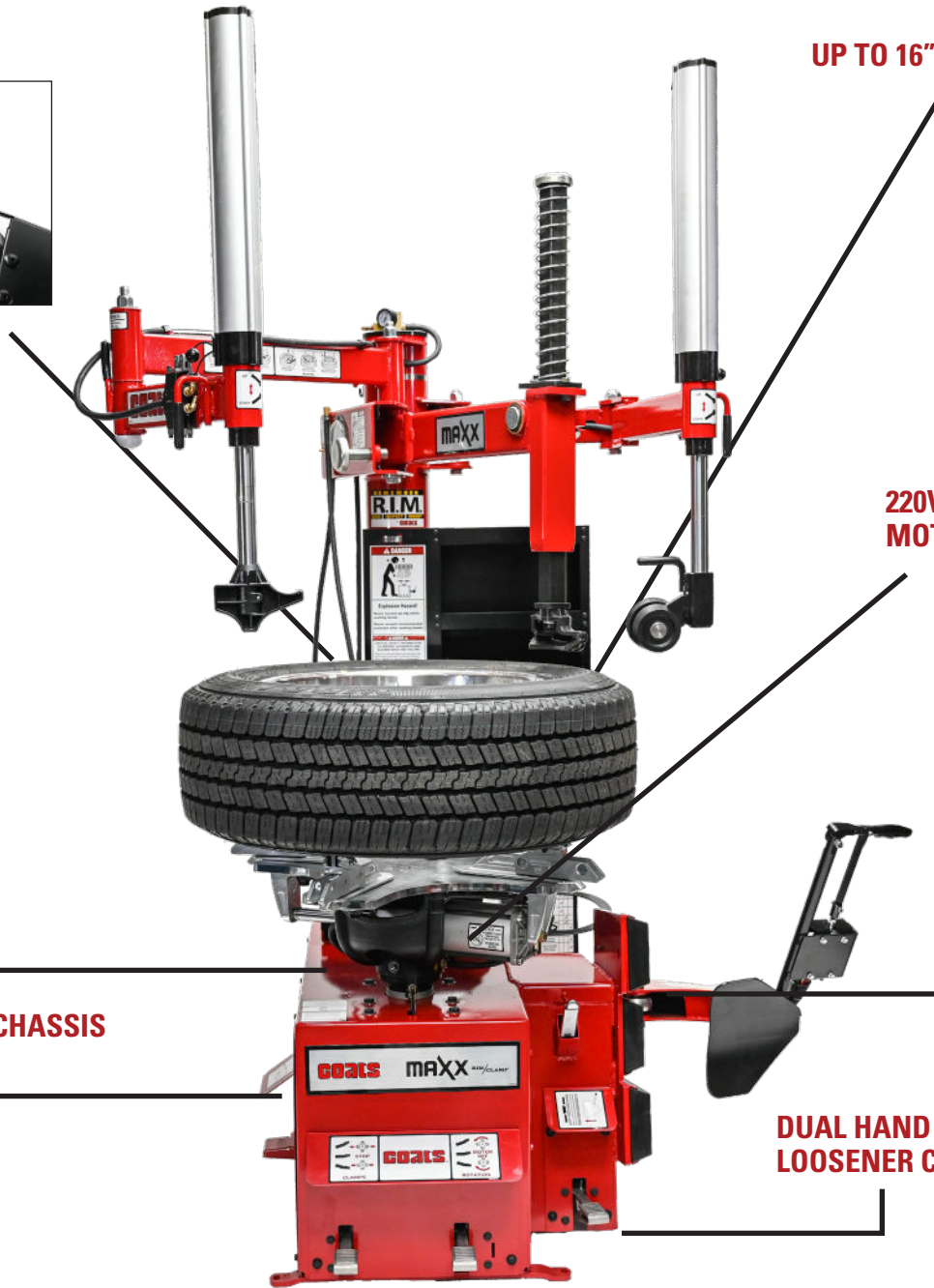

220V 2HP ELECTRIC MOTOR



CLAMPS 6" - 24" WHEELS

NO INDEX TABLETOP

WIDE CHASSIS

DUAL HAND AND FOOT BEAD LOOSENER CONTROLS

WHO WE ARE

The COATS Company is a leading, global manufacturer and distributor of service equipment and solutions. Based in Nashville, TN, we work with shops and dealerships around the world.

WHAT WE DO

- ✓ Maximize your uptime with our durable & reliable products
- ✓ Improve productivity with the fastest floor to floor times
- ✓ Provide easy to use equipment and solutions to our customers

Drawing on decades of expertise, market perspective, and innovative engineering, Coats keeps you ready for the next industry evolution.

WHY COATS

- ✓ **Legacy-** For over 75 years COATS has been trusted by shops and dealers across the country
- ✓ **Reliability-** Customer and technical service when you need it the most
- ✓ **Profitability-** Our products make your shop or dealership more efficient and profitable

SPECIFICATIONS

Wheel Handled	Alloy, Steel for Car & Light/Medium Truck
Rim Diameter	6-24"
Maximum Tire Diameter	50"
Maximum Rim Width	16"
Bead Loosening Width	Up to 22" Wide
Wheel Clamping System	4 Clamps, Air Cylinder Operated
Bead Seating Air Volume	5.4 Gallons in Tower
Air Drive System	Up to 4 HP*
Electric Drive System	220V 2 HP Electric, 110V Electric Motor
220V Electric Requirements	220V, 10amps, 1PH, NEMA L6-20
Footprint	74" w x 86" h x 44" d
Ship Weight	850 lbs. Low center of gravity for stability
Warranty	3 Year Parts, 6 Months Labor
Part Numbers	Electric 220V: 800MAXX80220 Electric 220V, 2-speed: 800MAXX802SPD Electric 110V: 800MAXX80 Air: 800MAXX80A

*Max air motor HP dependent on shop air pressure

EQUIPMENT FOOTPRINT

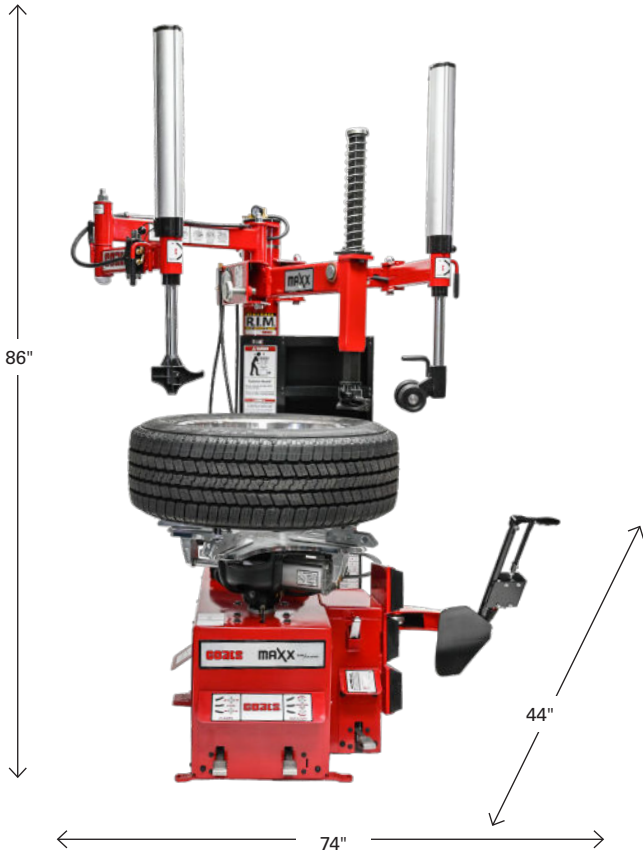

INCLUDED ACCESSORIES

Part Number	Description
8183606	Bead Loosener Shoe Socks - 2
85009048	Paste Lube Bracket & Brush
8183061	Polymer Duckhead
8184432	High Spoke Duckhead® Mount/Demount Tool
8182788	Steel Duckhead® Mount/Demount Tool
85612106	GripMax 2.0 Clamps - 4
8184126EX	Steel Clamps
85000783	Lift Tool Socks - 10
85610105	Premium Storage Cabinet

RECOMMENDED OPTIONAL ACCESSORIES

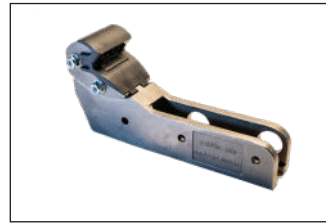

GRIPMAX 30" EXTENDED CLAMPS - 4
(PN 85607986)



AUXILIARY BEAD SEALER (ABS)
(PN 85606545)

Visit our website for videos, interactive content, and virtual training

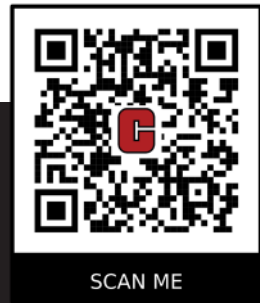

GOATS
SERVICE NETWORK
Servicing Coats, AMMCO
and BaseLine products

SALES: 1-855-876-3864
SERVICE: (800) 688-6359
TEXT FOR SERVICE: (615) 392-3193
Please provide: Serial #, Shop Name, Full Address

- Free Setup & Training
- Preventative Maintenance
- Technical Support Team