

COATS®

H.I.T. 5000

Truck Tire Changer

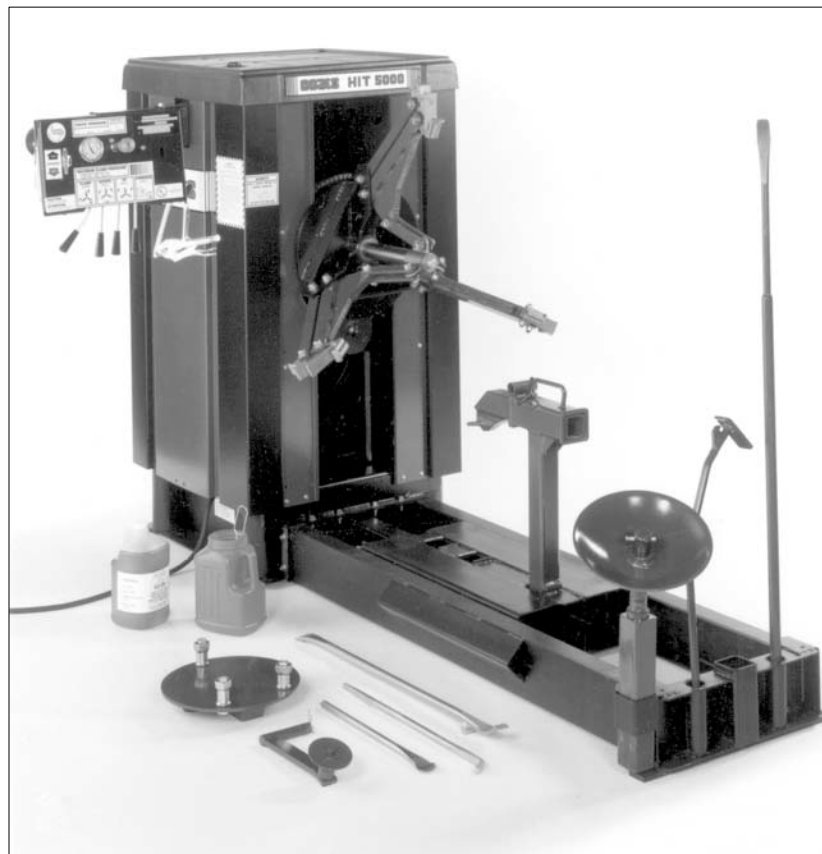

Parts Identification

READ these instructions before placing unit in service KEEP these and other materials delivered with the unit in a binder near the machine for ease of reference by supervisors and operators.

HENNESSY INDUSTRIES, INC.

1601 J. P. Hennessy Drive, LaVergne, TN USA 37086-3565 615/641-7533 800/688-6359

HENNESSY INDUSTRIES INC. Manufacturer of AMMCO®, COATS® and BADA® Automotive Service Equipment and Tools.

Manual Part No.: 7109391 04

Revision: 03/18

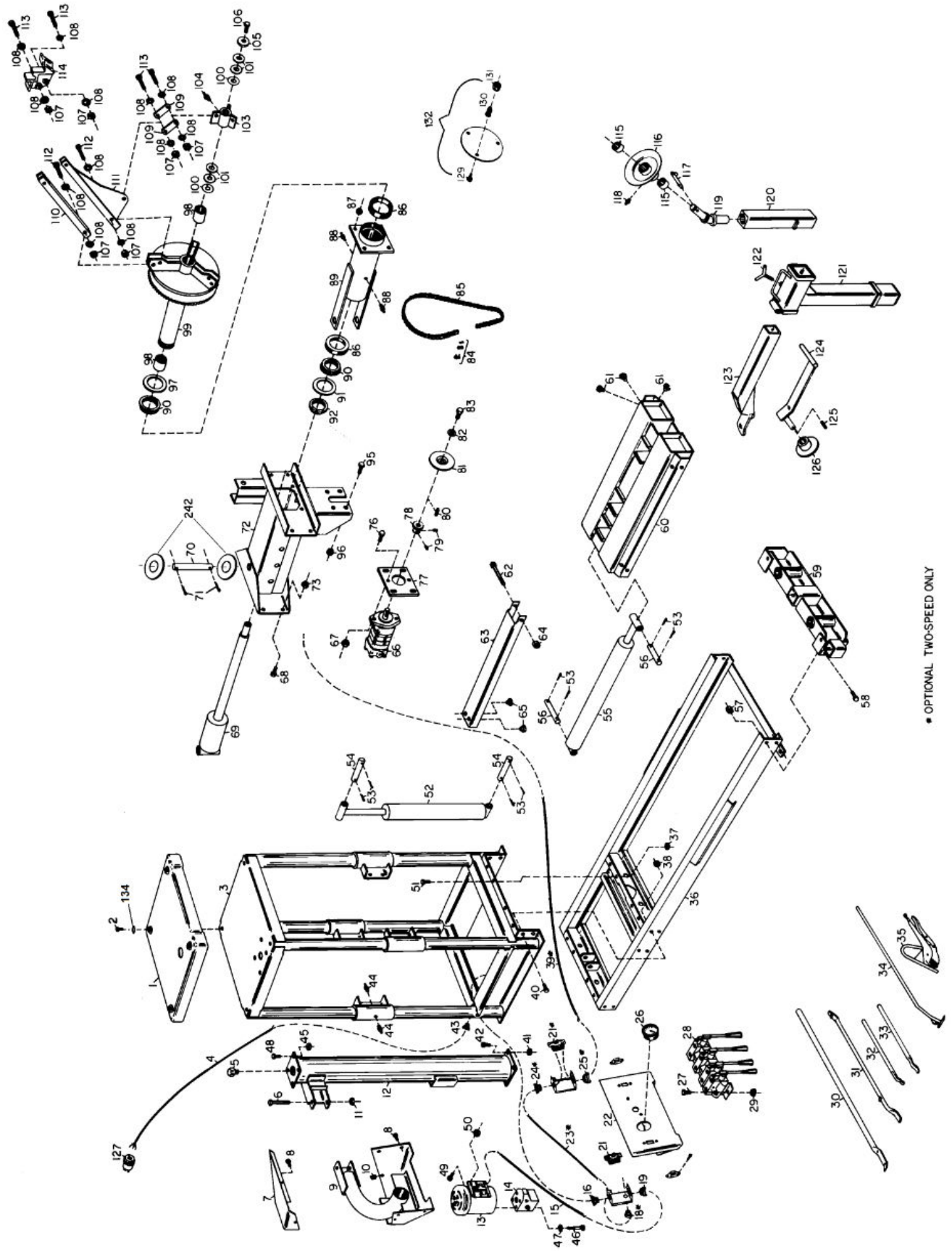

• OPTIONAL TWO-SPEED ONLY

Ref Part No.	Description	Ref Part No.	Description	Ref Part No.	Description
1	7109266	Plastic Top	57	8106303	3/8-16 Whiz Lock Nut
2	8106301	1/4" Hex Washer HD Self-Tap Screw	58	7110070	3/8-16 x 1-1/4 Self-Tap Bolt
3	7109111	Cage W/C	59	7109118	Front Bulkhead W/C
4	7109337	Power Cord 1Ph	60	7111085	Carriage W/C
4	7109595	Power Cord 3Ph	61	7110208	Carriage Rub Button
5	8120292	Breather Cap	62	8143815	3/8 x 3-1/2 HHCS
6	8109501	1/2-13 x 5-1/2 HHCS	63	7109208	Carriage Cylinder Cover
7	7109274	Pod Top	64	8106303	3/8-16 UNC Whiz Lock Hex Nut
8	8106301	1/4" Hex Washer HD Self-Tap Screw	65	8109350	Rub Button
9	7109119	Pod W/C	66	7109808	Hydraulic Motor Single-Speed
10	8143813	1/4" Tinnerman	67	8120458	1/2-13 UNC Nylock Hex Nuts
11	8301122	1/2-13 Hex Lock Nut	68	8106302	3/8-16 x 7/8 Ser Wash HD Screw
12	7109115	Reservoir W/C	69	7109122	Clamp Cylinder
13	85008941	Electric Motor 1 Ph	70	7109280	Pin Chuck Cylinder
13	85008942	Electric Motor 3 Ph	71	7109744	Hitch Pin
14	7108969	Hydraulic Pump	72	7109147	Torque Box W/C
15	7109338	Cord Motor 1 Ph	73	8106303	3/8-16 Whiz Lock Nut
16	7150128	Cable Connector	76	8120063	1/2-13 x 1.75 Whiz Lock Screw
18	7150128	Cable Connector	77	7109224	Hydraulic Motor Mounting Plate
19	7150128	Cable Connector	78	7109803	Sprocket Small
21	7110184	Switch 1 Ph	79	8180217	5/16-18 x 3/8" SHCS Gr5
21	7110184	Switch 3 Ph	80	7109353	Key
22	7109199	Pod Front	81	7109273	Guard Drive Sprocket
23	7109340	Cord - Two-Speed Switch	82	8301032	3/8 Flat Washer, Zinc Plate
24	7150128	Cable Connector	83	8106302	3/8-16 x 7/8 Whiz Lock HHCS Screw
25	7150128	Cable Connector	84	7109806	Master Link
26	7109226	Pressure Gauge	85	7109805	Chain
27	7109503	Bolt 5/16-3/4" 18 NC	86	7109172	Outer Bearing Race
28	7108977	Hydraulic Control Valve	87	8301122	1/2-13 UNC Nylock Hex Nuts
29	8182178	5/16-18 Whiz Lock Nut, Gr.5	88	7109348	Grease Fitting
30	8120334	Spade Tool	89	7109173	Bearing Housing W/C
31	7109342	Tire Iron Lock Tubeless	90	7109162	Inner Bearing Race
32	7109343	Tire Iron Lock Ring	91	7109124	Washer Chuck Pivot
33	7109344	Tire Iron Drop Center	92	7109131	Spanner Nut
34	7109345	Bead Starting Tool	95	8140825	1/2-13 x 1-3/4 Ser Washer HD Screw
35	7109346	Vise Grip	96	8301122	1/2-13 UNC Nylock Hex Nuts
36	8109110	Frame W/C	97	7109124	Washer Chuck Pivot
37	8106303	3/8-16 Whiz Lock Nut	98	7111657	Bushing Sprocket Tube
38	8106303	3/8-16 Whiz Lock Nut	99	7110127	Chuck-Sprocket Tube W/C
39	7109337	Cord - Two-Speed Motor Block	100	7109294	Shim Clamp Spider .015
40	7110070	3/8-16 x 1-1/4 Self-Tap Bolt	101	7109295	Shim Clamp Spider .030
41	8106303	3/8-16 Whiz Lock Nut	102		
42	8181137	3/8 x 2-1/4 HHCS	103	7109116	Clamp Actuator w/Assembly
43	8150128	Cable Connector	104	7109348	Grease Fitting
44	7109348	Grease Fitting	105	7109210	Washer Front Clamp Spider
45	8106303	3/8-16 Whiz Lock Nut	106	7109357	5/8" x 1 HHCS
46	8109349	5/16 x 3-1/4 HHCS	107	8301121	Chuck Washer
47	8120421	5/16 Lock Washer	109	7108974	Link Cylinder Pivot
48	8106302	3/8-16 x 7/8 Ser Wash HD Screw	110	7108970	Link Clamp
49	7109503	5/16-18x3/4 Screw, Washer Hex Cap	111	7109117	Clamp Strut w/Assembly
50	8182178	5/16-18x18 Whiz Lock Nut-Hex	112	7109307	Bolt Chuck Face
51	7110070	3/8-16 x 1.25 Whiz Lock Screw	113	7109308	Bolt Chuck Claw
52	7108966	Vertical Cylinder	114	7110829	Jaw Clamp
53	8103006	Cotter Pin	115	8109287	Bushing Disk
54	7109276	Pivot Pin Cylinder	116	8109288	Disk W/C
55	7108967	Carriage Cylinder			
56	7109276	Pivot Pin Cylinder			

ITEMS NOT SHOWN:

Ref Part No.	Description
133	7110852 Offset Roller
135	7110841 Carriage Lock Pin
136	7110652 Earth Mover Bead Loosener Shaft

Ref Part No.	Description
201	Hose Filter to Reservoir
202	Hose Clamp
203	Fitting
204	Hose Reservoir to Pump
205	Hose Pump Pressure Relief
206	Hose Pump to Valve
207	Clamping Hose Valve (Rear)
208	Clamping Hose Valve (Front)
209	Hose Valve to Chuck Valve
210	Adapter Fitting
211	Hose - Gauge
212	1/4-20 x 3/4 Hex Hd Cap Scr Gr.5
213	Check Valve Block
214	Hose Check Valve Block to Filter
215	Hose Clamp Cylinder Rear
216	Filter Element
217	Reducer
218	Filter Head
219	1/4" Hex Washer HD Self-Tap Screw
220	90° Tube Fitting
221	Hose Clamp Cylinder (Front)
222	Vertical Cylinder Hose Top
223	Vertical Cylinder Hose Bottom
224	Carriage Cylinder Hose (Rear)
225	Carriage Cylinder Hose (Front)
226	90° Fitting
227	Hose Hydraulic Motor
228	Hose Hydraulic Motor
229	Hose Hydraulic Motor to Filter
230	Reducer
231	Two-Speed Motor Block
232	Corner Panel Side
233	Panel Rear
234	Panel Side Operator Side
235	1/4" Hex Washer HD Self-Tap Screw
236	Front Panel Operator Side
239	Front Panel Opposite Operator Side
240	Panel Side Opposite Operator
241	Tinnerman
244	1/2" NPT x 1/2" Hose Fitting
245	3/4 - 1/2" Strainer
246	Hydraulic Tee 1/4" NPT
247	Hydraulic Nipple 1/4" NPT x 4" Lg
248	Hydraulic Nipple 1/4" NPT x 2" Lg
249	Adapter 1/4 NPT/#6 SAE Fig
250	Accumulator

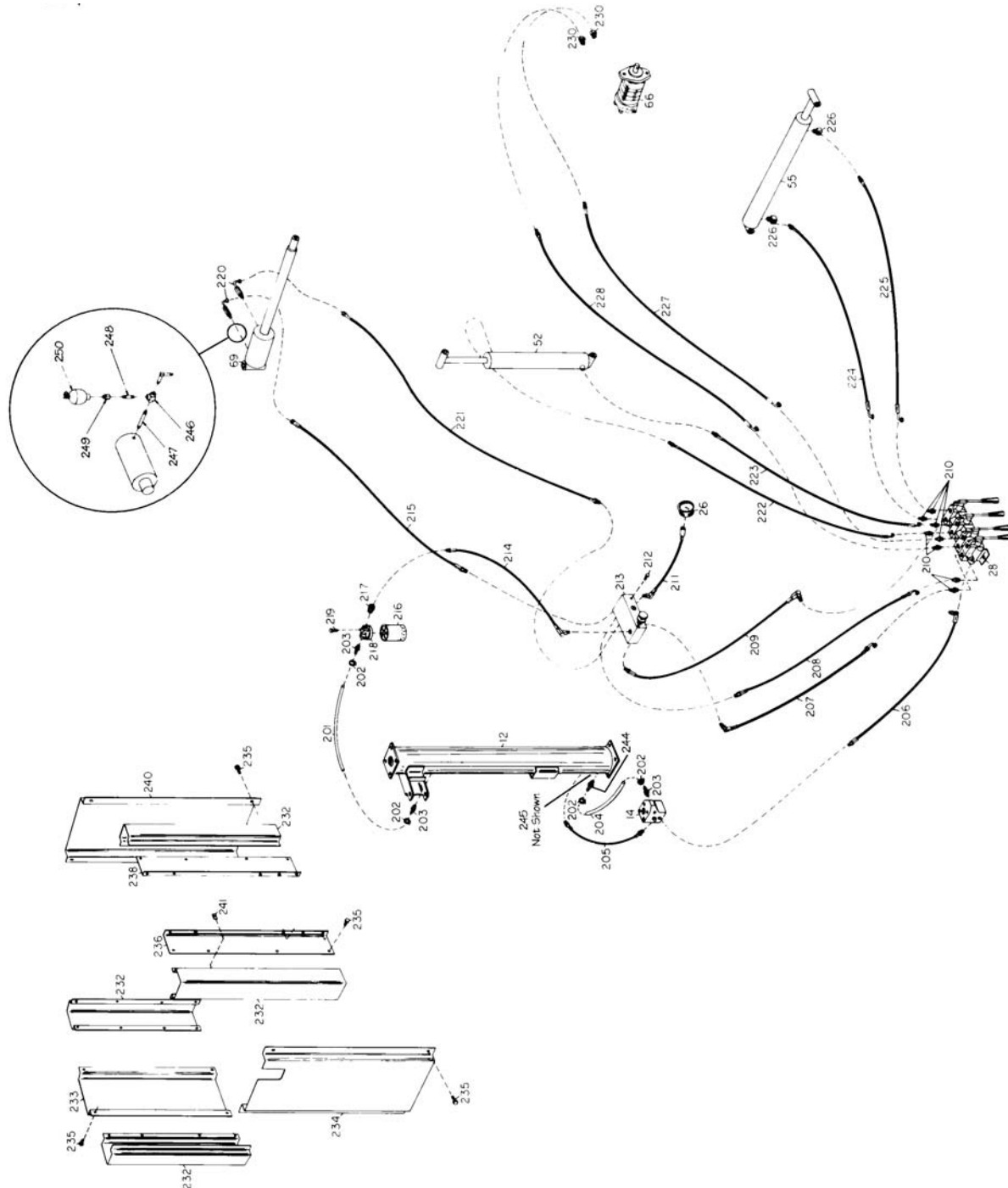

When ordering parts always give the following information:
 (1) Part Number (2) Description (3) Serial Number of Your Machine