

# GENERAL REPAIR

Complete Your Shop With  
Coats® Equipment



## PIT LIFT 6,600 LB. / 3.0T CAPACITY

Compact Design Ideal  
for Tires, Brakes, Body  
Repair & Fast Lube



Air Release Mechanical Locking



Light Truck Frame Adapter

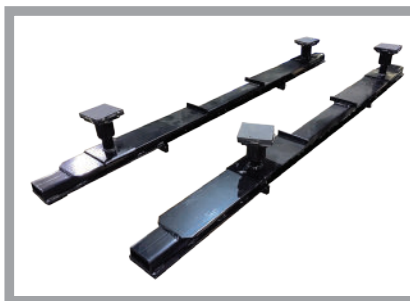

Space Saving Design



Compact design that makes this lift fit in  
virtually any shop

PIT LIFT 6,600 LB. / 3.0T CAPACITY

To learn more about the Coats Pit Lift, or  
any of our other quality products, contact  
your authorized Coats distributor or call  
1-855-876-3864 for the dealer nearest you.

# COATS®

**CONTACT US NOW**

[www.coatsgarage.com](http://www.coatsgarage.com)  
or call 1-855-876-3864

# PIT LIFT 6,600 LB. / 3.0T CAPACITY

LEGENDARY RELIABILITY WITH STATE OF THE ART CAPABILITY.

SPECIFICATIONS	
Capacity	6,600 lb. / 3.0Kg
Power Supply	2 HP, 1 PH or 220v, 12amp
Hydraulic Cylinders	2 - 3" x 15" long / 76mm x 381mm long
Lifting Time	25 Seconds (220v)
Overall Width	78 3/4" / 2000mm
Overall Length	86 1/2" / 2200mm
Drive Over Height	4 1/8" / 105mm
Overall Lifting Height	39 3/8" / 1000mm (42" / 1066mm with adapters)
#of Mechanical Locks	5
Lock Release	Air cylinder lock release
Finish	Double bake coat
Height Adapters	4" / 101mm Rubber covered blocks
Lifting Pad Dimensions	61" to 82 1/2" Extended x 23 1/2" wide / 1550 to 2100mm Extended x 597mm wide
Equalization	Volumetric
Available In Flush Mount	Yes
Pull Out Deck Extension	Yes
Optional Light Truck Frame Adapter	Yes
Shipping Weight	850 lb. / 385 kg
Country Of Manufacture	Italy
Part Number	4TS6SSOR1

## FEATURES

- Compact design - rugged construction** - Small foot print takes up less bay space while still allowing best in class weight capacities. Only 78 3/4" / 2000mm wide x 86 1/2" / 2200mm long.
- Versatility and ease of use** - Ideal for small compact cars up to light duty trucks with pull out extensions allowing ease of use on short or long wheelbase vehicles. No tie bar or floor obstruction.
- Volumetric control stays level all the time** - Thanks to single cylinder with dual chamber, unit stays level all the time. No electronic sensors required on the lift.
- Lower maintenance - less downtime** - No Electronic sensors, No equalization valve, Extra-large pins with accessible grease fittings makes this ideal equipment for high duty cycle shops who require less downtime.
- Built for safety** - 5 locking positions ensure side to side stability and eliminates accidental lowering of the lift. Single point air cylinder lock release.
- Unobstructed access** - Open front and rear construction with no tie bars or torsion rods allows for unobstructed access to the underside of most vehicles with 27" / 686mm to 38" / 965mm of working area between the superstructures.
- Easy vehicle spotting** - The flat deck platform and "spotting blocks" allows quick set-up by the operator increasing bay productivity.
- Low profile approach ramps or flush mount options** - The low profile ramps 4 1/8" / 105mm collapsed height allow for accessibility of smaller compact cars while still allowing for heavier loads. The lift can also be flush mounted for the ultimate in productivity and space saving bay solutions.

## EQUIPMENT FOOTPRINT

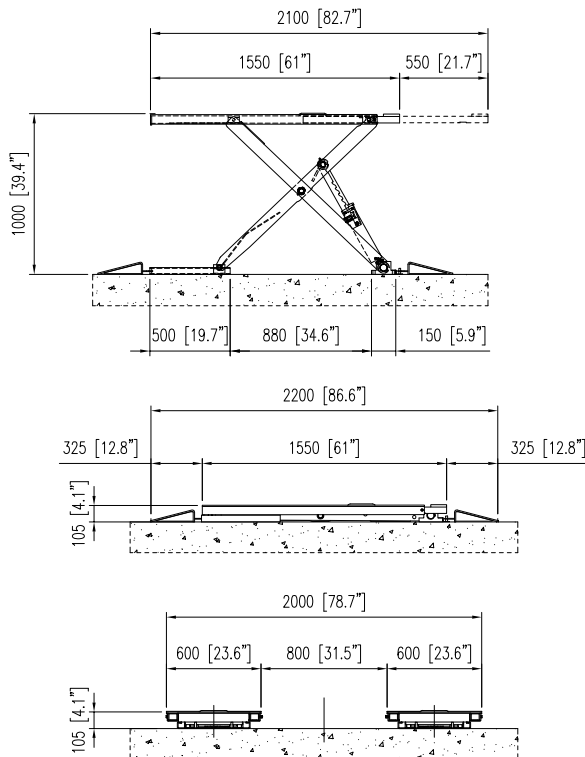

**COATS**