

COATS®

1250 2D/3D/3DV
1255 3D/3DV
Wheel Balancers



Parts Identification

READ these instructions before placing unit in service. KEEP these and other materials delivered with the unit in a binder near the machine for ease of reference by supervisors and operators.

HENNESSY INDUSTRIES, INC.

1601 J. P. Hennessy Drive, LaVergne, TN USA 37086 615/641-7533 800/688/6359 www.ammcoats.com
HENNESSY INDUSTRIES INC. Manufacturer of AMMCO®, COATS® and BADA® Automotive Service Equipment and Tools.

Manual Part No.: 8114308 26
Revision: 5/15

Parts Identification

The following pages include parts breakdowns with exploded view illustrations to help with ordering replacement or spare kits. Assemblies are noted where it is recommended that individual parts not be ordered separately. Note that the parts view illustrations are for multiple models and not all parts shown are on all models. Every effort is made to supply accurate exploded views, however, due to interim changes in manufacturing operations, some units may not be exactly as illustrated.

Table of Contents

Wheel Guard Assembly.....	3
Chassis Assembly	4
Distance Gauge Assembly	5
Motor Assembly	6 - 7
Pod & Touch Panel Assemblies	8 - 9
Power Panel & MCB	10 - 11

Wheel Guard Assembly

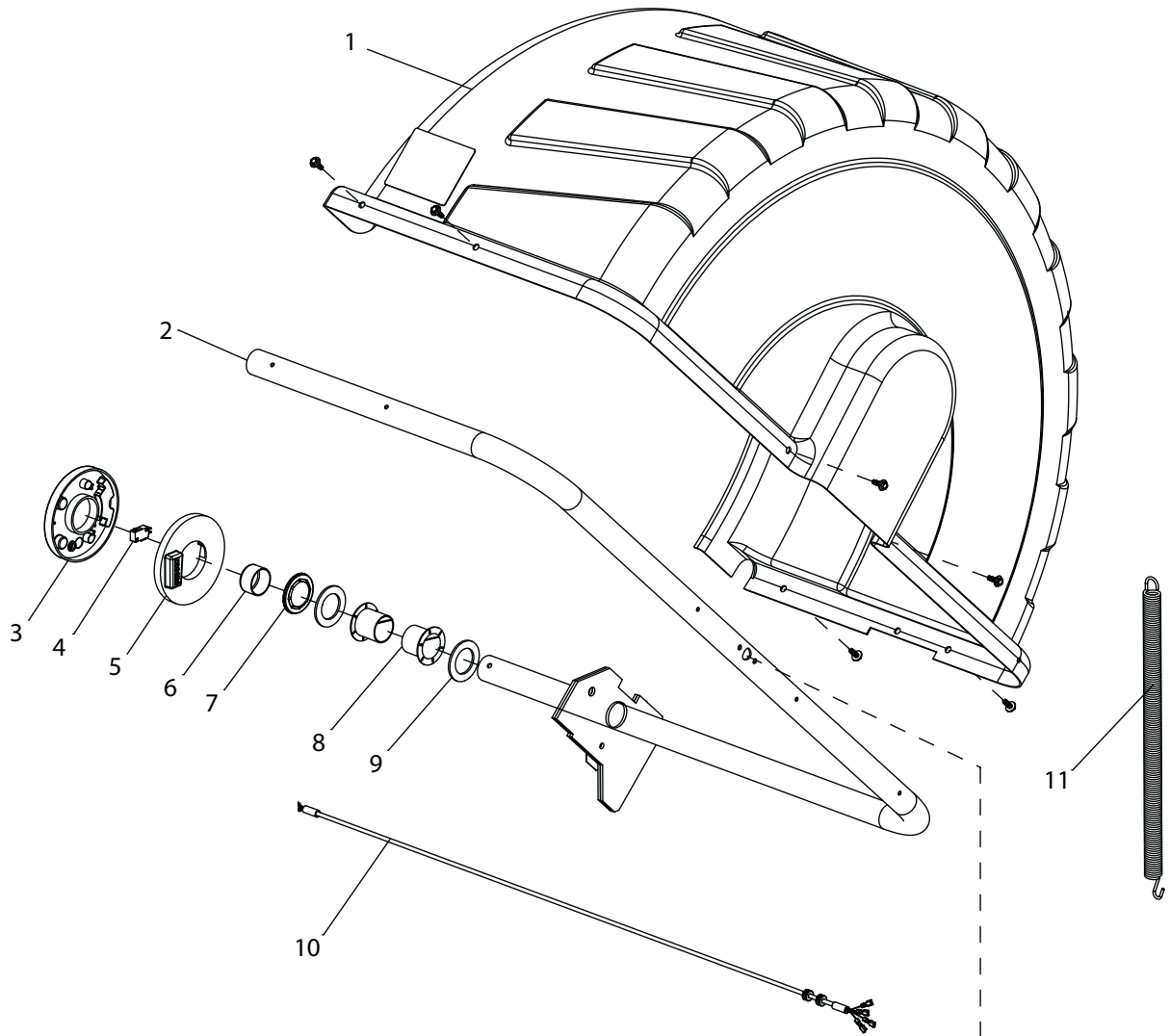

Item	Part No.	Description
1	8113620	Wheel Guard
2	8114319	Hood Bar W/C
3	8113333	Hood Switch Housing
4	8113334	Limit Switch
5	8113332	Hood Switch Cam/Cover
6	8109949	Hood Bar Cap
7	8109945	1-1/2" Retainer Washer
8	8307014	Flanged Nylon Bearing
9	8109944	Hood Bar Washer
10	8114262	Hood Switch Cable Assembly
11	8308062	Hood Spring
12	85000303	Sonar Bracket
13	85000304	Sonar Module
14	85000305	Sonar Cable Assembly

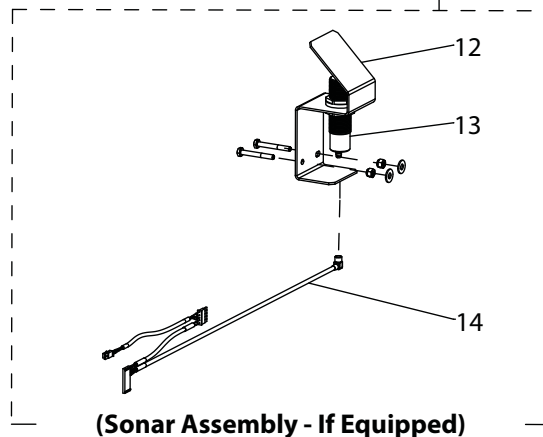

Chassis Assembly

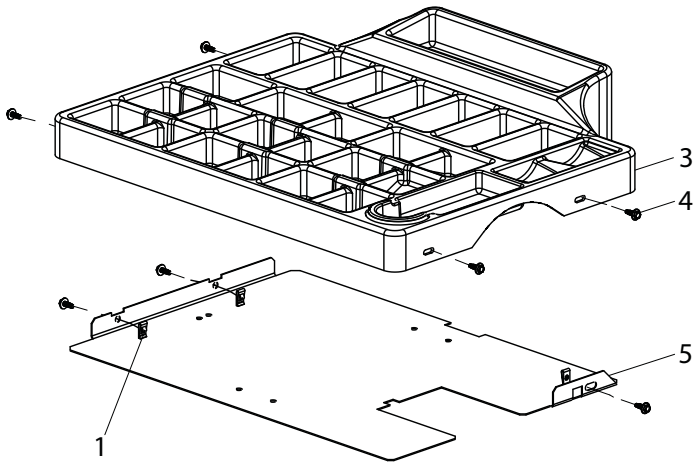

Item	Part No.	Description
1	8106304	1/4-20 Tinnerman Nut
2	8110560	#8-32x3/4 Screw
3	8111034	Weight Tray Assembly
4	8106301	1/4" Hex Self-Tap Screw
5	8111064	Weight Tray Shield
6	8108727	Threaded Rod
7	8106303	3/8-16 Hex Jam Nut
8	8114266	Piezo Assembly
10	8111029	Rear Harness Cover
11	8113333	Hood Switch Housing
12	8113332	Hood Switch Cam/Cover
13	8113334	Limit Switch
14	8301120	1/2-13x2-1/2 HH Bolt
15	8301121	1/2 Flat Washer
16	8309008	Rubber Hood Stop
17	8301122	1/2-13 Hex Nut
18	85606581	Flex Grommet

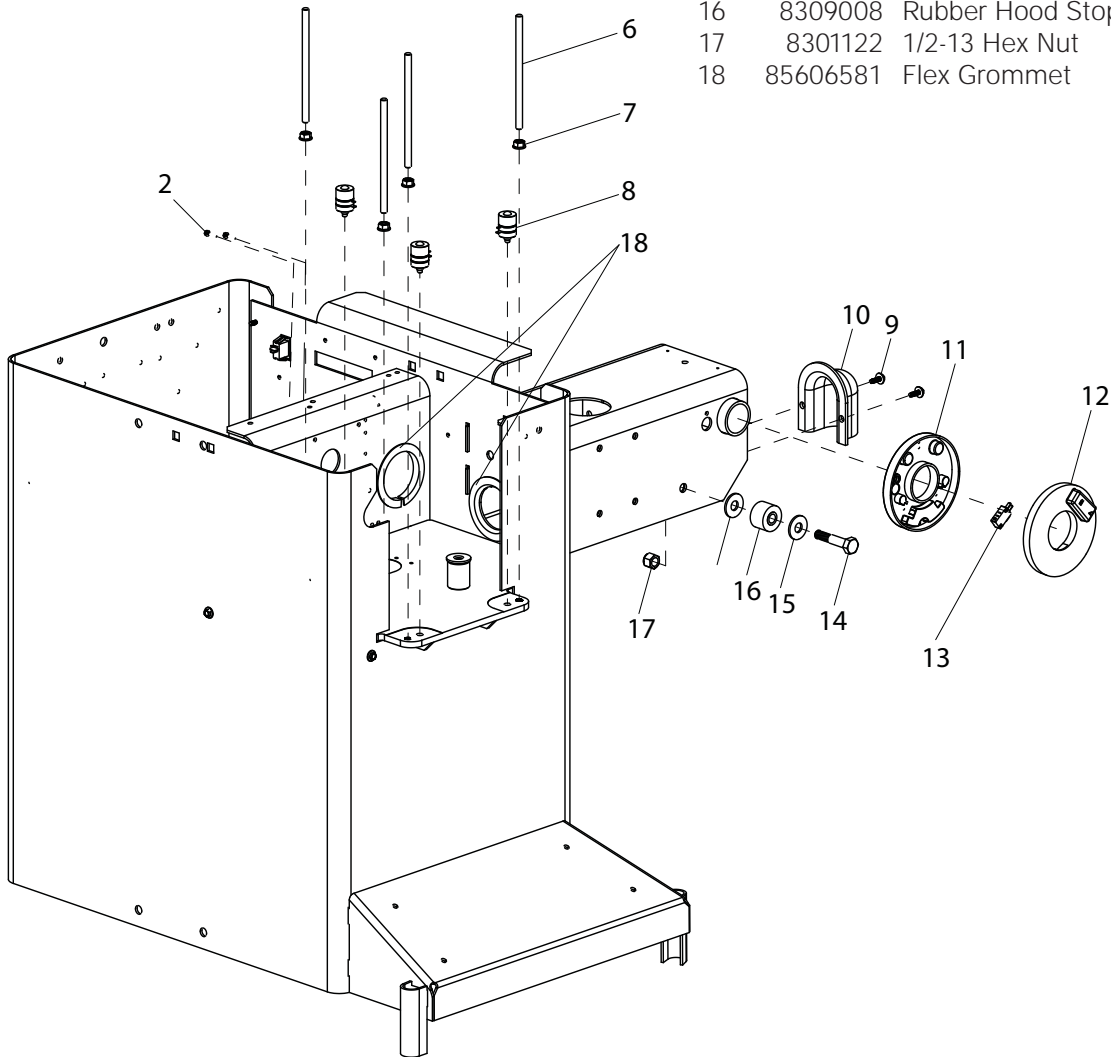

Distance Gauge Assembly

Item	Part No.	Description
1	8114254	A & D Pendulum
2	8114251	A & D Bracket
3	8114257	A & D Pots with Harness Assy
4	85000730	Distance Rod Bushing
5	80180018	A & D Rod
6	8114258	A & D Pot Bracket
7	8301084	#8-32 Kep Nut
8	8114327	Distance Pot Pulley
9	80180022	String
10	8114403	Pulley Collar
11	8112317	10-32 Keps Nut
12	80180020	Spring Bracket, 3MM Screw
13	80180021	Washer 3MM
14	80180019	String Bracket
15	80180023	Spring
16	8114253	Cone
17	85009229	Line Laser
19	8111173	1/4-20 x 1-1/2 FHS Screw
20	8114380	Compression Spring
21	8114379	SHC 1/4-20 x 1-1/4 lg.Screw
22	8114264	Hose Clamplp
23	8114255	A & D Tube
24	85000731	Hex HD Cap Screw
25	8111032	1/4 Fender Washer
26	8114373	Arm
27	903174	Retaining Ring
28	8301534	1/4-20 x 7/8 HHC Screw
29	8143169	1/4-20 Whiz Lock Hex Nut
30	8111542	#8-32 X 5/8" SEM Screw
31	8100964	1 1/4-inch Retaining Ring
32	85000732	A&D Arm Tube Assembly Kit
33	85609880	M6 x 12mm SHSSCP Screw

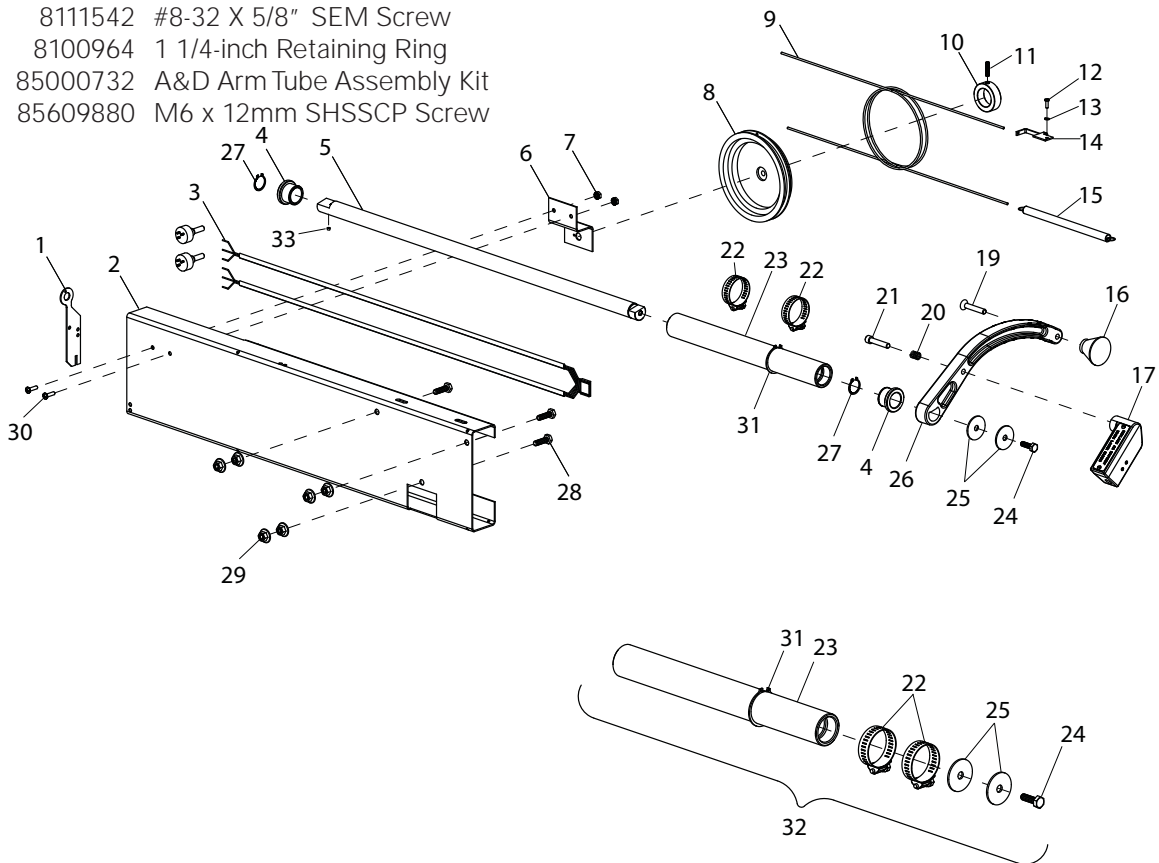

A & D Tube Assembly Kit

Motor Assembly

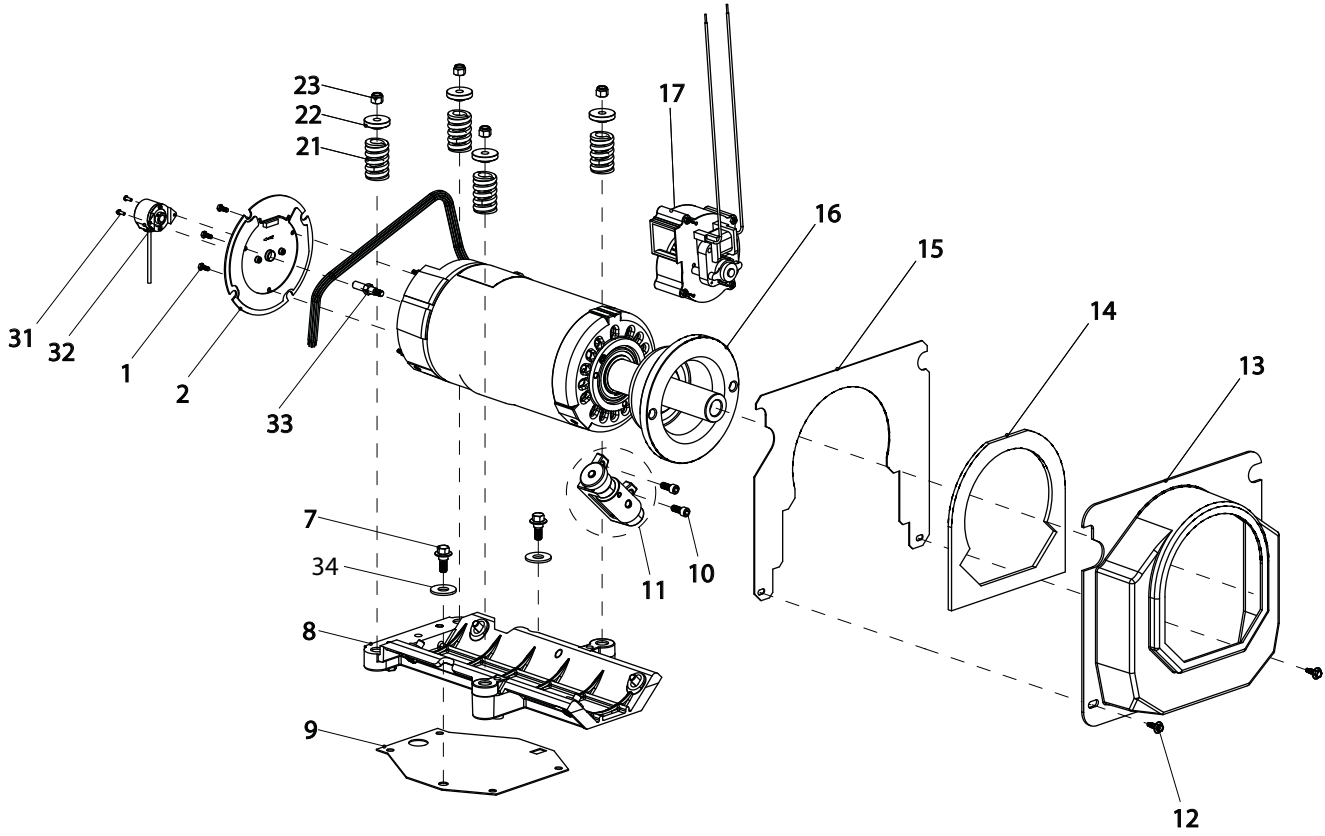

Motor Assembly - 40mm

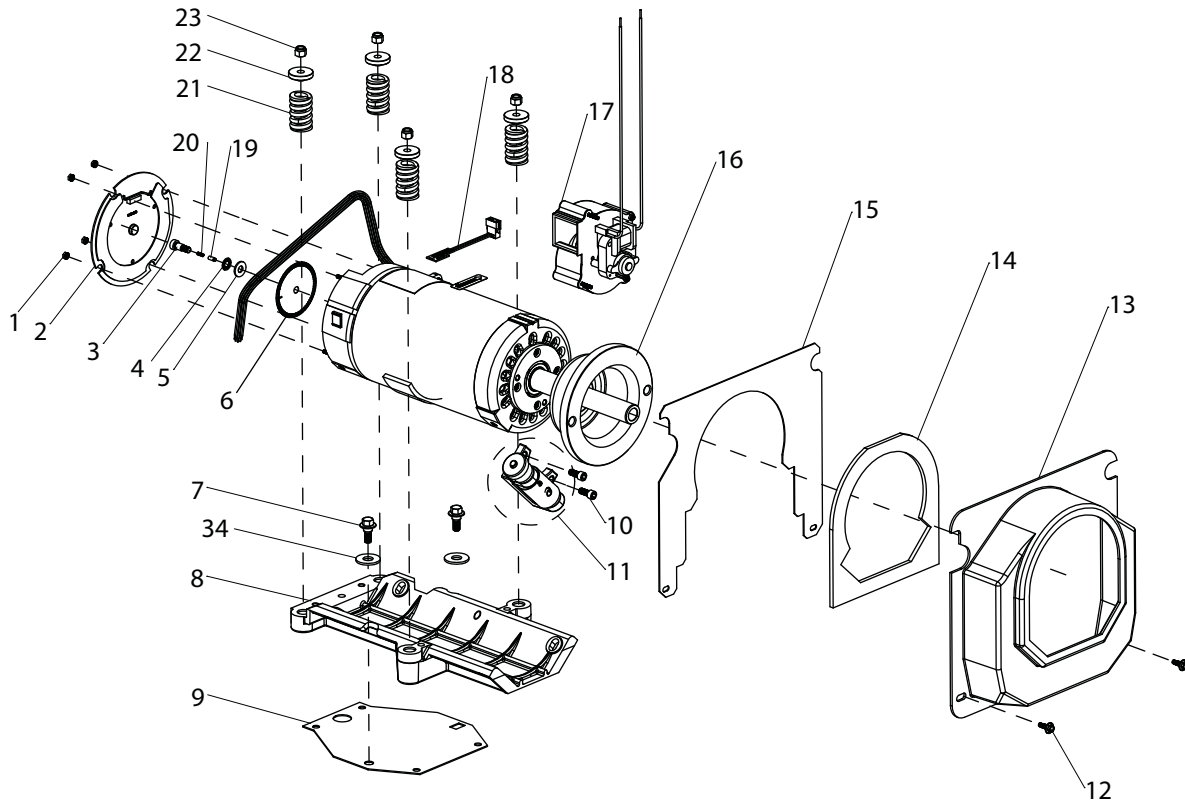

Motor Assembly - 28mm

(Motor Assembly)

Item	Part No.	Description	Item	Part No.	Description
1	8112191	10-24 x .50 HHMS Screw	21	8307008	Piezo Spring
2	8308513	Rear End Bell Cover (28mm)	22	8308036	Piezo Spring Retainer
	85009970	Rear End Bell Cover (40mm)	23	8301035	3/8-16 Nyloc Nut
3	8113559	Brush Holder	24	8114243	Modified Screw
4	8104200	3/8 Lock, Internal Tooth Washer	25	8182025	1/4" Ball
5	8107635	5/16 Plain Washer	26	8114239	Laser Bracket
6	8308817	Rotary Shutter	27	8114237	3/8 x 2 Dowel
7	*85609427	3/8-16 x 1/2 SHSHS Screw	28	8114241	Knob
8	8110430	Motor Cradle	29	8114242	Plastic Washer
9	8112182	Flex Plate	30	902308	1/4" Set Screw
10	8182149	5/16 x 3/4 HHC Screw	31	8301067	#6-32 x 0.38 PPHMS Screw
11	8114326	Laser Housing Assembly	32	85009972	Motor Encoder
12	8106301	1/4" Hex Self-Tap Screw	33	85009971	Encoder Drive Shaft
13	8111552	Motor Shroud Assembly	34	8301121	1/2" Flat Washer
14	8308536	Motor Gasket			
15	8111308	Motor Cover Shield			
16	85000710	Motor Replacement Kit (28mm)			
	85010010	Motor Replacement Kit (40mm)			
17	8114265	Fan Assembly, 220 VAC			
18	8110923	Encoder Assembly			
19	8113560	Carbon Bushing			
20	8113561	Brush Spring			

* Before S/N 0606304914 use 8120325

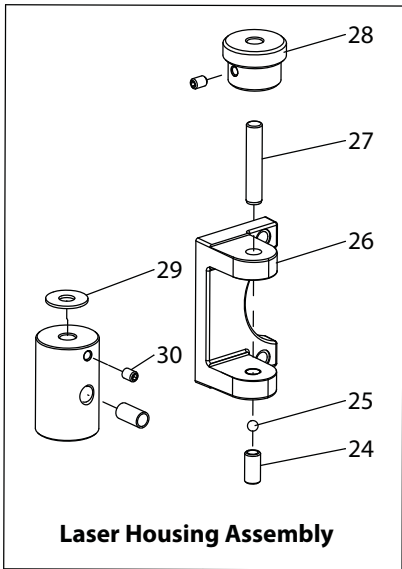

11

Pod & Touch Panel Assemblies

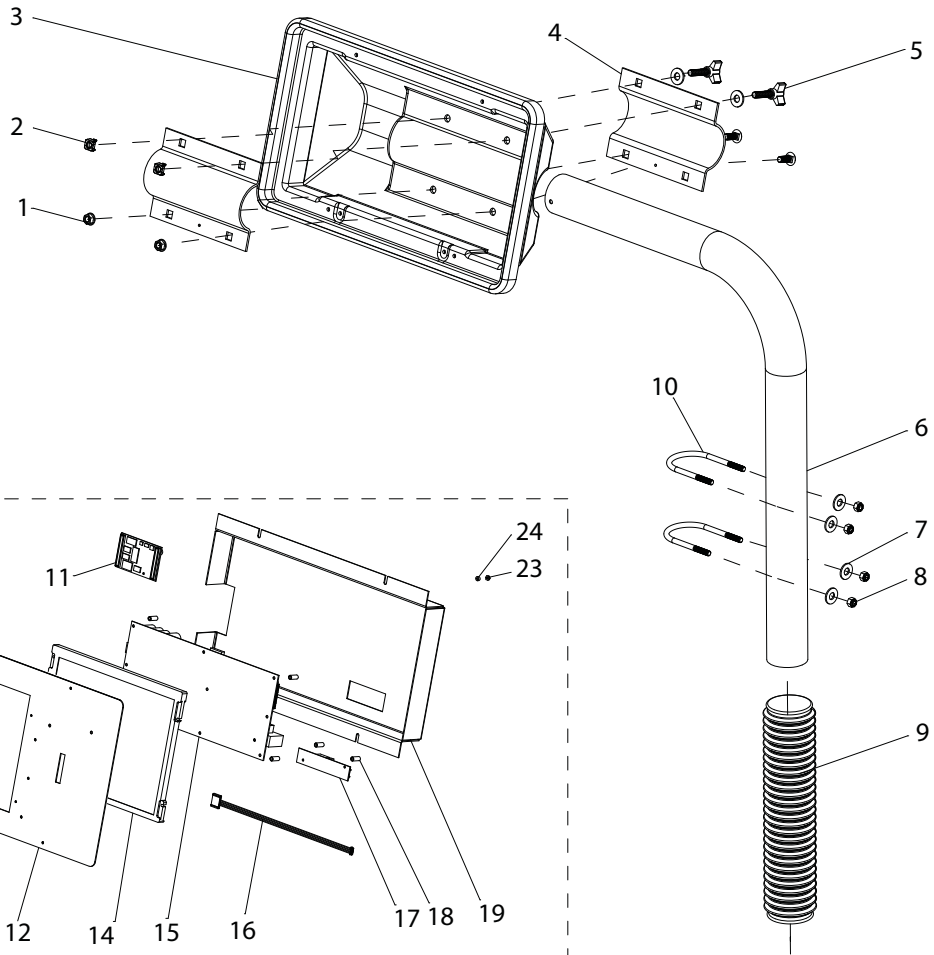

(Touch Panel Assembly For 1250 Video)

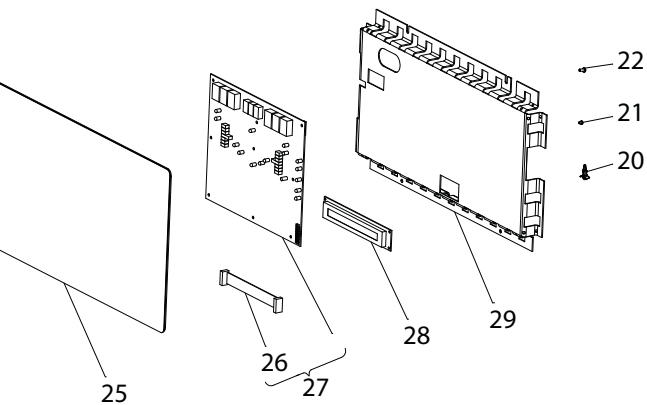

(Touch Panel Assembly For 1250 Non-Video)

(Pod & Touch Panel Assemblies)

Item	Part No.	Description
1	8111055	Nut, #6-32 Acorn
2	8143044	3/8-16 Tinnerman Nut
3	8111031	Pod Electronics Sub Assembly
4	8110795	Pod Mounting Bracket
5	8110823	3/8-16 Carriage Bolt
6	8110805	Support, Pod Tube
7	8301032	3/8 Flat Washer
8	8181183	5/16-18 Nyloc Nut
9	8110800	Pod Tube Cover
10	8110789	Bolt, 5/16-18 " U"
11	85000116	Single Board Computer
12	85000398	Touch Panel (1250/1255 3DV)
14	85609273	*Display LCD, with Inverter Package
15	85000049	LCD Driver 12503DV PCB
16	85000307	Inverter Cable Assembly (5 wire)
	85609164	Inverter Cable Assembly (6 wire) started with serial number _____
17	85609273	AC to DC Inverter
18		Aluminum Stand Off
19	85000306	EMC Shield
20	85000361	Snap-Lock Standoff
21	928487	4-40 x 3/16 Pan Hd. Screw
22	8301067	6-32 Phillip Hd. Screw
23	85000357	Nylok #4-40 Nut
25	85010013	Touch Panel (1250 2D/3D)
	85606425	Touch Panel (1255 3D)
26	8114313	VFD Cable Only
27	85000846	PCB Display & Cable Assembly
28	8114302	Vacuum Fluoresent Display
29	8113624	EMC Shield, UL Model (Austr. Export)

* When installing a new LCD display, the inverter PCB must also be replaced. These two components do not interchange with the old components. The new LCD display and inverter PCB started with serial number _____.

Power Panel & MCB

Item	Part No.	Description	Item	Part No.	Description
1	8112356	Capacitor	13	85000264	Power Supply Assembly (Video)
3	8111860	Capacity Panel Assembly	14	8113101	Power Cord Assembly, 1 PH
4	8110821	Power Panel		8143127	Power Cord Assembly, 3 PH
5	85000361	Stand-off, Snaplock		8114417	Power Cord Assy (440 V Export)
6	8114412	Motor Control PCB (Non-Inverter Model)	15	8114184	Cover
	85606375	Motor Control PCB (Inverter Model)	16	8113907	Processor PCB
7	8305076	220V, 1 PH Plug	17	8301804	#10-32 Hex Nut
	8140786	220V, 3 PH Plug	18	8114420	Filter Wire Assembly (Austr. Export)
	8114410	440V, 3 PH Plug (Export)	19	8114211	Cat 5, 2 Meter Lg. Cable
8	8113845	EMI Line Filter (Austr. Export)	20	8114260	Piezo Harness Assembly
9	906058	Strain Relief	21A	8114430	Encoder Cable Assy (Non-Inverter Model, 1250-2D or Present 1250-3DV 28mm)
10	8305802	ON/OFF Switch	21B	85009988	Hood Switch Cable Assembly (Inverter Model, 1250-3D or 1250-3DV)
11	928347	Hole Plug			
12	8301082	#8-32x1/2 PHM Screw			

2D & 3D Non-inverter Drive Models

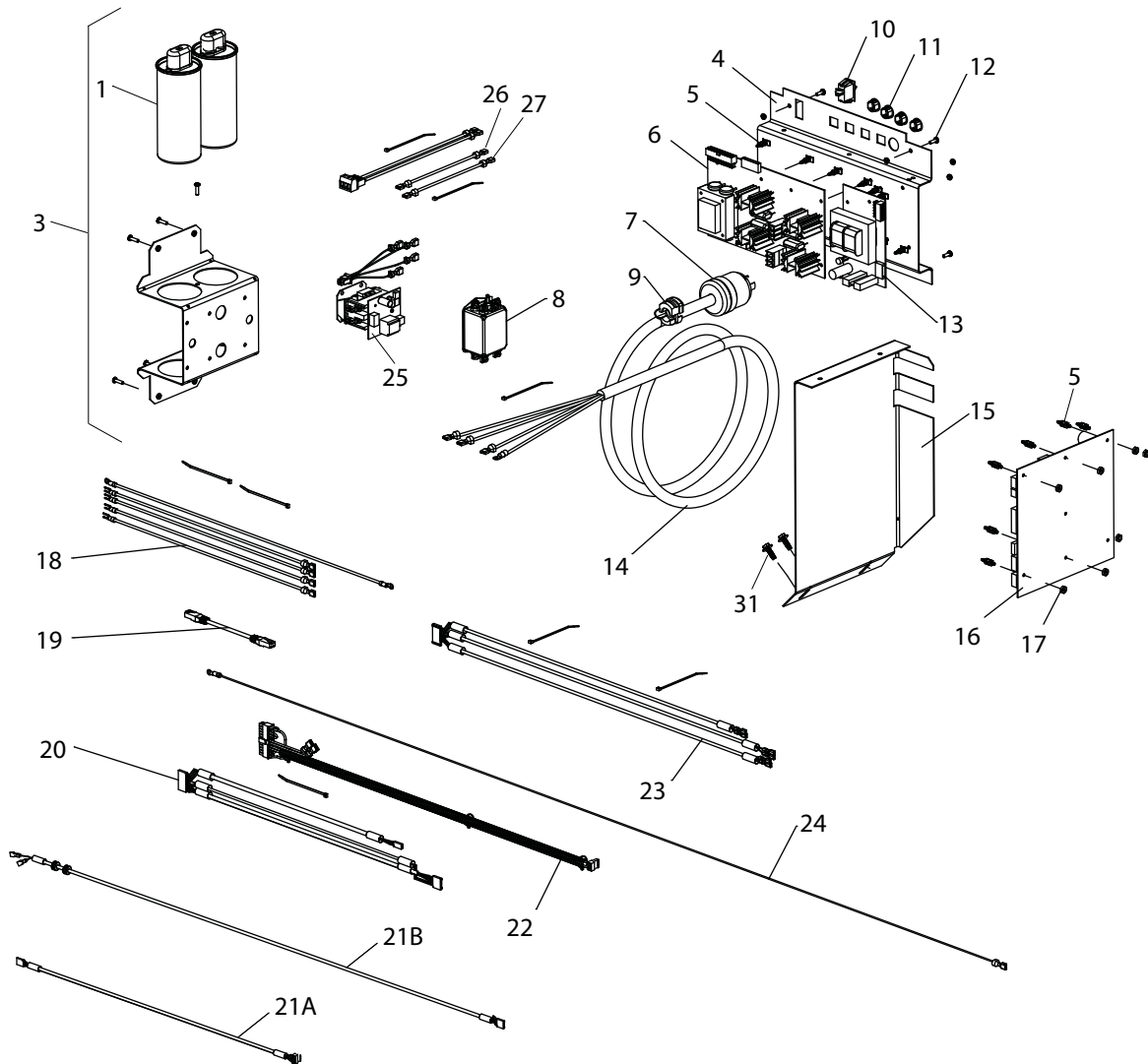

Item	Part No.	Description	Item	Part No.	Description
22	8114208	240 VAC Harness Assembly	33	85009999	Harness Wire Cover
	8114420	440 VAC Harness Assy (Export)	35	85009973	Inverter
23	8114260	Harness Assembly	36	8114259	MCB Cable Assembly
24	8114212	Drain Wire Assembly	37	85010025	Interface, Encoder Cable
25	85000705	Motor Module Assembly, 1 PH	38	85000305	SNR Cable Assy
	85000704	Motor Module Assembly, 3 PH	39	85010022	Motor Harness Wire Assembly
26	8309057	Wire Assembly	40	85010024	GRND Wire Assembly, 26"
27	8309005	Wire Assembly	41	85010014	Interface, Inverter, Encoder Cable
28	85606582	Trim Strip	42	85010030	#2-56 Hex Nut
28	8112208	8-32 Male, 3/8" Standoff			
29	85009993	Interface, Inverter Card			
30	85010029	#2-56 x 1/4 PPHMS Screw			
31	8106301	1/4-20 x 3/4, HWHST Screw			
32	85009994	Interface, SLR Card			

3D & 3DV Inverter Drive Models — Baldor

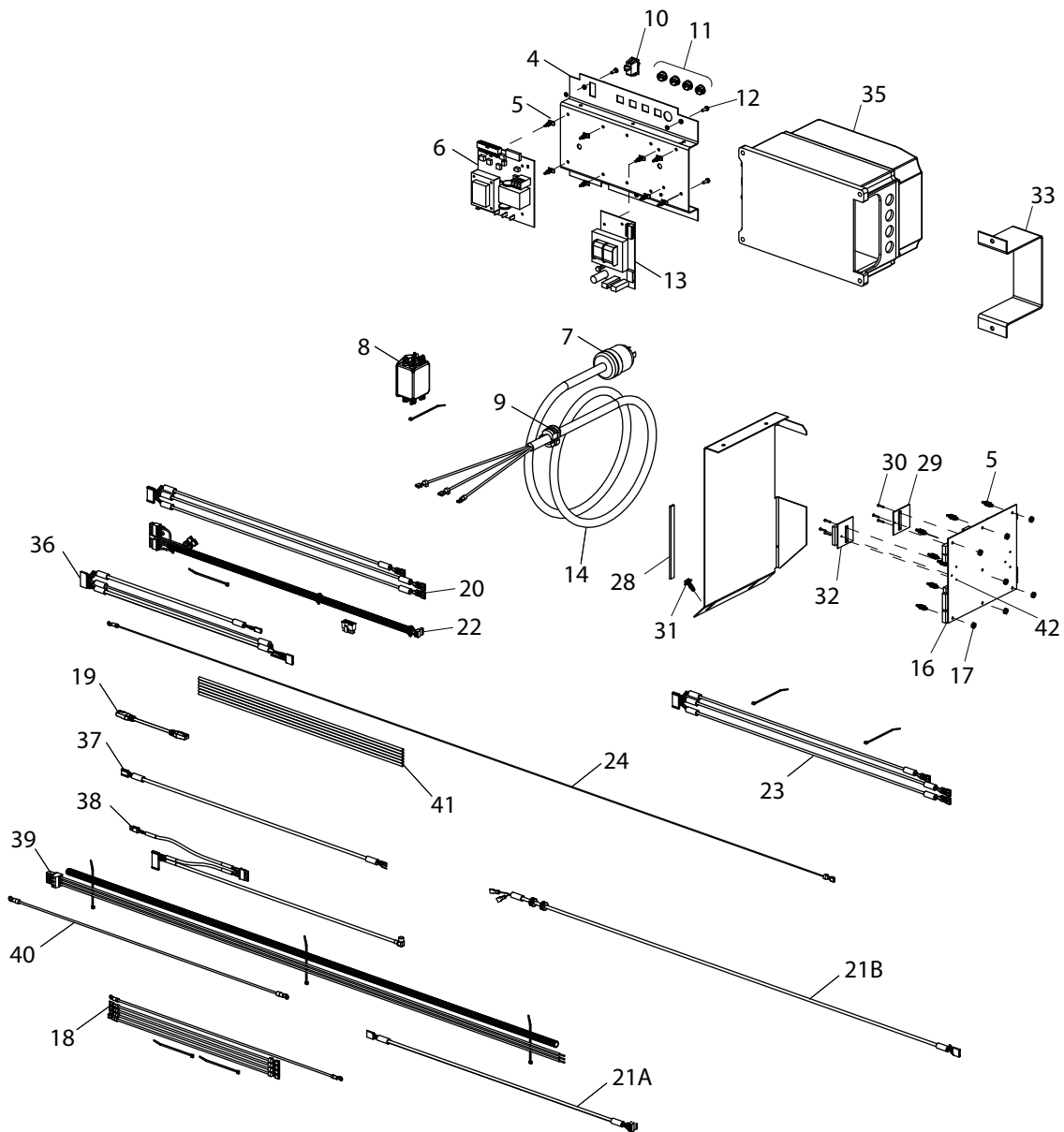

Inverter Drive Model — Emerson

Item	Part No.	Description
1	85610073	Inverter Cover w/Decal
2	85609942	Inverter - Emerson
3	8305802	ON/OFF Switch
4	8301082	#8-32 x 1/2 PHM Screw
5	8110821	Power Panel
6	85000361	Stand-off, Snaplock
7	85606375	Motor Control PCB
8	8305015	Double Side Adapter
9	806058	Strain Relief
10	8305076	1 Ph Plug, L6-20P
11	8113101	Power Cord Assembly, 1 Ph
12	85606582	Trim Strip
13	8106301	1/4" Hex Self-Tap Screw
14	85009994	Sonar Interface PCB
15	85009993	Inverter Interface PCB
16	85010030	#2-56 Hex Nut
17	8113996	Circuit Board Standoff
18	85609932	Processor PCB - Emerson
19	8301804	#10-32 Hex Nut
20	85608188	Fan Harness Assembly, 220V
21	8114260	Piezo Harness Assembly
22	8114259	MCB Cable Assembly
23	85609961	Interface, Inverter, Encoder Cable
25	8114211	Cat 5, 2 Meter Lg. Cable
27	85010022	Motor Harness Wire Assembly
28	85009988	Hood Switch Cable Assembly
29	85010024	Ground Wire Assembly, 26"
31	85609352	White 14 AWG Wire Assembly, 16"
32	8110977	Black 14 AWG Wire Assembly, 24"
33	8114212	Drain Wire Assembly
34	8111055	Lock Nut with Nylon Collar
35	85610095	Comm. Cable, Emerson Assy.
36	85609951	Optical Isolator Module
37	8113927	Safety Decal
38	8111542	8-32 x 5/8 Lg. PHP SEM Screw
39	85610063	Terminal Block Mounting Bracket
40	8106304	1/4-20 Tinnerman Nut
41	8301084	#8-32 Kep Nut (Ground)
42	85610065	Inverter U-bracket
43	8114010	Flat Washer
44	85610070	M4 0.7 x 30 HHCS Screw
45	85609997	Inverter Base Plate, Emerson
46	928347	Hole Plug
47	85606375	Motor Control PCB (Inverter Model)
48	85000264	Power Supply Assembly (Video)

*Not Shown

