

COATS®

10,000 lb. (4,536 kg)

2n1 Two Post Lift

3 Piece Front & Rear Arms

4TV21NSR1 (Standard)

4TV21NXR1 (Extended)

4TP21NSR1 (Premium)

4TP21NXR1 (Premium Extended)



Installation Manual Operation Manual Service Parts Manual

READ the manual thoroughly before installing, operating, servicing, or maintaining the lift. SAVE this MANUAL and ALL INSTRUCTIONS.

HENNESSY INDUSTRIES

1601 J.P. Hennessy Drive, LaVergne, TN 37086 (800) 688-6496 or (615) 641-7533

Hennessy Canada: 2430 Lucknow Drive, Unit 9, Mississauga, Ontario L5S 1V3 (905) 672-9440 www.coatsgarage.com

HENNESSY INDUSTRIES INC. Manufacturer of AMMCO®, COATS® and BADA® Automotive Service Equipment and Tools.

Manual Part No.: 85611154 00

Revision: 6/17

Your new lift will provide years of dependable service if installed, operated and maintained properly. Read and be prepared to follow all safety, installation, operation, and maintenance instructions in this manual before installing and operating the lift. In addition, read and follow all safety and other info included on and with the lift before operating the lift. Keep this manual in a secure place for future reference, training and service part identification.

Table of Contents

UNLOADING PROCEDURE & LIFT PACKAGE CONTENTS	3
IMPORTANT SAFETY INSTRUCTIONS.....	5
SAFETY INSTRUCTION AND INFORMATION DECAL KIT	7
OWNER/EMPLOYER’S RESPONSIBILITIES.....	8
GENERAL REQUIREMENTS & LIFT SPECIFICATIONS	9
BAY CLEARANCE	10
TOOLS REQUIRED & PRE INSTALLATION PROCEDURES	11
INSTALLATION PROCEDURE.....	12
OPERATING INSTRUCTIONS & LIFT MAINTENANCE	15
LIFT OPERATIONAL TEST WITH A TYPICAL VECHILE:	16
LIFT MAINTENANCE SCHEDULE.....	18
LIFT PROBLEM TROUBLESHOOTING GUIDE	21
LIFT ILLUSTRATIONS & PARTS LISTS	22
Diagram #1: LIFT COLUMNS AND COLUMN EXTENSIONS	22
Diagram #2: LIFT TOWER ASSEMBLY.....	23
Diagram #3: CARRIAGE ASSEMBLY	24
Diagram #4: OVERHEAD CROSSMEMBER ASSEMBLY	25
Diagram #5: LIFT LEVELLING - COLUMN SHIMING - ANCHOR BOLTS	27
Diagram #6: EQUALIZING CABLES	28
Diagram #7: SAFETY RELEASE CABLE	29
Diagram #8: SAFETY CABLE GUIDE ASSEMBLY	30
Diagram #9: LIFT ARMS AND ARM RESTRAINTS	31
Diagram #10: HYDRAULICS	34
Diagram #11: POWERPACK INSTALLATION	35
Diagram #12: SAFETY LOCK COVER & EXTENSION BRACKET	36
Diagram #13: SAFETY INSTRUCTION and INFORMATION DECAL KIT LOCATION	37
Diagram #14: WIRING DIAGRAM (1PH MOTOR)	38

IMPORTANT:

It is the shop owner's responsibility to provide a satisfactory installation area for the lift. Lifts should only be installed indoors on level concrete floors with a minimum of 4 inches (102mm) and 3000 psi (20.7MPa) concrete that has been aged a minimum of 30 days. Please consult a qualified individual if any doubt exists concerning proper installation and subsequent safe operation of the lift. Do not install the lift on asphalt or outdoors.

Prior to installation, it is the shop owner's responsibility to provide constant electrical power in the correct voltage, phase, etc., and all wiring for electrical hook-up of the lift. The shop owner must insure that the electrical installation conforms to local building and safety codes. Where required, the shop owner will provide an electrical isolation switch located in close proximity to the lift. This switch will have an emergency stop capability and isolate electrical power from the lift for servicing requirements.

Hydraulic oil cannot be shipped with the lift and will be supplied by either the shop owner or the installer. ISO 32 hydraulic oil (10W non detergent hydraulic oil) must be used to fill the reservoir tank before operating the lift.

It is the shop owner's responsibility to train all operators in lift operation and safety.

UNLOADING PROCEDURE & LIFT PACKAGE CONTENTS

For your information:

All lift components are grouped together in one package held at each end by steel frames.

Unpacking Procedure:

When the lift arrives on site:

- ✓ If possible have lift unloaded in the installation area.
- ✓ Check for freight damage and report immediately to the shipping company.
- ✓ Check for missing parts and report immediately to the factory. 1-877-799-LIFT(5438) or (905) 847-1198

Main Components include:

- Power Side Column and Carriage Assembly – 1 pc (c/w equalizing cable, 2 arm restraint assemblies and 1 hydraulic cylinder assembly)
- Opposite Side Column and Carriage Assembly – 1 pc (c/w equalizing cable and 2 arm restraint assemblies and 1 hydraulic cylinder assembly)
- Column Extensions – 2 pc
- Overhead Crossmember – 3 pc (c/w 4 steel cable pulleys)
- Overhead Safety Shutoff Bar – 1 pc
- Arms – 4 pc (c/w arm restraint gear assemblies)
- Powerpack Assembly – 1 pc

Accessory and Hardware Box includes:

- Micro-switch for Overhead Safety Shutoff Bar - 1pc (c/w 2 mounting brackets and hardware)
- Baseplate Shims (6mm - 3mm - 1mm assortment) - Anchor Bolt Assemblies - 10 pc
- Arm Pins – 4 pc (c/w roll pins to secure them)
- Adjustable Rubber Lifting Pad Assembly – 4 pcs
- Stack Pad Adapter (3") – 4 pcs (only with "V and P" series lifts)
- Stack Pad Adapter (6") – 4 pcs (only with "V and P" series lifts)
- Truck Adapter – 4 pcs
- Rubber Door Guards – 2 pcs (only with "P" series lifts – not with "V" series)
- Outer Arm (Honda) Adapter – 2 pcs (only with "P" series lifts – not with "V" series)
- Hydraulic Hose – 2 long and 1 short (also 1 hydraulic "T" fitting and powerpack adapter fitting)
- Rubber Mounts for Powerpack - 4 pcs
- Safety Lock Release Cable – 1 pc (c/w 2 pulley brackets and fittings)

- Safety Lock Cover – 2 pcs
- Fittings Box (bolts, washers, nuts, screws, cable ties, etc.)
- ALI - "Lifting It Right" Manual
- Automotive Lift Safety Tips Hang Card
- Automotive Lift, Operation, Inspection and Maintenance Manual
- Owner's Manual

IMPORTANT SAFETY INSTRUCTIONS

When using your garage equipment, basic safety precautions should always be followed, including the following:

1. Read all instructions
2. Care must be taken as burns can result from touching hot parts
3. Do not operate equipment with a damaged cord or if equipment has been dropped or damaged – until it has been examined by a qualified service person
4. Do not let a cord hang over the edge of the table, bench, or counter or come in contact with hot manifolds or moving fan blades
5. Let equipment cool completely before putting away. Loop cord loosely around equipment when storing
6. To reduce risk of fire, do not operate equipment in the vicinity of open containers of flammable liquids (gasoline)
7. Adequate ventilation should be provided when working on operating internal combustion engines
8. Keep hair, loose clothing, fingers, and all parts of body away from moving parts
9. To reduce the risk of electric shock, do not use on wet surfaces or expose to rain
10. Use only as directed in this manual. Use only manufacturer's recommended attachments
11. ALWAYS WEAR SAFETY GLASSES. Everyday eyeglasses only have impact resistant lenses, they are not safety glasses

Basic common-sense safety precautions should always be followed when installing, operating and maintaining the lift as a risk of fire, electric shock, or injury may be present.

In addition:

1. Read and follow all safety instructions and decals included with the lift. Read and follow all safety instructions in this manual. Read and follow the ALI "Lifting It Right" manual (included with the lift). Always use the "Vehicle Lifting Points" reference guide when lifting a vehicle. Insure all materials stay up to date(www.autolift.org/)
2. Only trained and authorized personnel should position a vehicle and operate the lift. Do not allow customers or bystanders to operate the lift or be in the lift area.
3. Inspect the lift daily. Do not operate if potential problems have been identified or lift malfunctions. Do not operate if lift has damaged or broken components. Never walk or work under the lift unless all safety locks are completely engaged.
4. Never overload the lift. The rated capacity decal is located on the powerpack column. The hydraulic system on this lift is not designed to be a load holding device. Mechanical safety locks must be engaged before proceeding under the lift, with vehicle servicing, or system maintenance. Never override operating controls. This is unsafe and will void the warranty.

5. Before driving a vehicle between the columns, position all arms to insure unobstructed entry. Do not hit or run over arms as this could damage the lift and/or vehicle.
6. Use all 4 arms to raise a vehicle. Position all lift pads to contact vehicle manufacturer's recommended lifting points. Raise lift slowly until all pads contact the vehicle. Check all pads for complete and secure contact with the vehicle. Check all arm restraints to insure they are engaged properly. Check that vehicle is stable on the lift. Only after confirming these procedures, raise the lift to desired working height.
7. Special care must be used when lifting pick-up trucks. Optional truck adapters may be required to reach manufacturer recommended lifting points. Always use these lifting points. Running boards and other installed accessories may also require optional adapters. Insure contents of the cargo box will not affect vehicle balance while on the lift.
8. **Important:** Removal or installation of heavier parts can change the vehicle's center of gravity on the lift resulting in a critical load shift. The vehicle may then be unstable. Plan ahead for this possibility to insure continued safety and refer to the vehicle manufacturer's service manual for recommended procedures.
9. Always keep the lift area free of obstructions and debris. Clean up grease and oil spills immediately.
10. Never raise a vehicle with passengers inside. Before lowering a vehicle, check the lift and lift area and remove all obstructions. Before removing vehicle from the lift or lift area, position arms to the drive through position and confirm an unobstructed exit.

SAFETY INSTRUCTION AND INFORMATION DECAL KIT

IMPORTANT: Review all safety information daily with all lift operators.

 CAUTION Lift to be used by trained operator only.	 CAUTION Authorized personnel only in lift area.	 WARNING Clear area if vehicle is in danger of falling.	 WARNING Position vehicle with center of gravity midway between adapters.
 CAUTION Use vehicle manufacturer's lift points.	 CAUTION Always use safety stands when removing or installing heavy components.	 WARNING Remain clear of lift when raising or lowering vehicle.	 WARNING Avoid excessive rocking of vehicle while on lift.
 CAUTION Use height extenders when necessary to ensure good contact.	 CAUTION Auxiliary adapters may reduce load capacity.	 WARNING Do not override self-closing lift controls.	 WARNING Keep feet clear of lift while lowering.

The messages and pictographs shown are generic in nature and are meant to generally represent hazards common to all automotive lifts regardless of specific style.
Funding for the development and validation of these labels was provided by the Automotive Lift Institute, PO Box 85 Cortland, NY 13045.
Replacement label sets may be obtained from the original lift manufacturer and ALI's member companies. They are protected by copyright.
www.autolift.org ©1992 by ALI, Inc. ALI/WL101s

The messages and pictographs shown are generic in nature and are meant to generally represent hazards common to all automotive lifts regardless of specific style.
Funding for the development and validation of these labels was provided by the Automotive Lift Institute, PO Box 85 Cortland, NY 13045.
Replacement label sets may be obtained from the original lift manufacturer and ALI's member companies. They are protected by copyright.
www.autolift.org ©1992 by ALI, Inc. ALI/WL101s

ATTENTION:
MOTEUR NON PROTÉGÉ—PROTECTION EXTERIEURE CONTRE LA SURCHAUFFE DOIT ETRE ASSUREE CONFORMEMENT AU CODE CE, PREMIERE PARTIE

CAUTION:
MOTOR NOT PROTECTED— EXTERNAL OVERHEAT PROTECTION IN ACCORDANCE WITH CE CODE, PART 1, MUST BE PROVIDED

COURANT ADMISSIBLE MINIMAL DE LA DERIVATION: 20A. MINIMUM CIRCUIT AMPACITY OF CONDUCTOR IS 20 A.

COURANT NOMINAL MAXIMAL DU FUSIBLE DE LA DERIVATION: 25 A. MAXIMUM BRANCH CIRCUIT FUSE IS 25 A.

AVERTISSEMENT: IL EST DANGEREUX DE TROP ARROSER LE MATERIEL ET LES CÂBLES ELECTRIQUES

WARNING: IT IS DANGEROUS TO OVERSPRAY THE ELECTRICAL APPARATUS AND WIRING

SI CONNECTÉ À UN CIRCUIT PROTÉGÉ PAR DES FUSIBLES UTILISER DES FUSIBLES À UNE ACTION DIFFÉRÉE MARQUÉS "D"

IF CONNECTED TO A CIRCUIT PROTECTED BY FUSES USE TIME DELAY FUSE MARKED "D"

NE PAS UTILISER À UN NIV. EAU INFÉRIEUR À CELUI DU PLANCHER DU GARAGE OU DU SOL

DO NOT USE BELOW GARAGE FLOOR OR GRADE LEVEL

CAUTION: RISK OF ELECTRIC SHOCK - DO NOT REMOVE COVER - NO USER SERVICEABLE PARTS INSIDE - REFER SERVICING TO QUALIFIED SERVICE PERSONNEL.

SAFETY INSTRUCTIONS: IF ATTACHMENTS, ACCESSORIES OR CONFIGURATION MODIFYING COMPONENTS THAT ARE LOCATED IN THE LOAD PATH, AFFECT OPERATION OF THE LIFT, AFFECT THE LIFT ELECTRICAL LISTING OR AFFECT INTENDED VEHICLE ACCOMMODATION ARE USED ON THIS LIFT AND, IF THEY ARE NOT CERTIFIED FOR USE ON THIS LIFT, THEN THE CERTIFICATION OF THIS LIFT SHALL BECOME NULL AND VOID. CONTACT THE PARTICIPANT FOR INFORMATION PERTAINING TO CERTIFIED ATTACHMENTS, ACCESSORIES OR CONFIGURATION MODIFYING COMPONENTS.

This piece of garage equipment is specified by the manufacturer for intermittent operation with a maximum "on" time of 60 seconds and a corresponding "off" time of 540 seconds for the equipment.

52100100

 SAFETY INSTRUCTIONS Read operating and safety manuals before using lift.	 SAFETY INSTRUCTIONS Proper maintenance and inspection is necessary for safe operation.
 SAFETY INSTRUCTIONS Do not operate a damaged lift.	<p>The messages and pictographs shown are generic in nature and are meant to generally represent hazards common to all automotive lifts regardless of specific style.</p> <p>Funding for the development and validation of these labels was provided by the Automotive Lift Institute, PO Box 85 Cortland, NY 13045.</p> <p>Replacement label sets may be obtained from the original lift manufacturer and ALI's member companies. They are protected by copyright.</p> <p>www.autolift.org © 1992 by ALI, Inc. ALI/WL101s</p>

**LIFT SAFETY and LIFT MAINTENANCE
MUST BE PART OF YOUR DAILY ROUTINE**

OWNER/EMPLOYER'S RESPONSIBILITIES

The owner/employer:

- Shall ensure that lift operators are qualified and that they are trained in the safe use and operation of the lift using the manufacturer's operating instructions; ALI/SM, "Lifting It Right" safety manual; ALI/ST, "Safety Tips" card; ANSI/ALI ALOIM, Standard for Automotive Lifts – Safety Requirements for Operation, Inspection and Maintenance; ALI/WL Series, ALI Uniform Warning Label Decals/Placards; and in the case of frame engaging lifts, ALI/LP-Guide, "Quick Reference Guide – Vehicle Lifting Points for Frame Engaging Lifts".
- Shall establish procedures to periodically inspect the lift in accordance with the lift manufacturer's instructions or ANSI/ALI ALOIM, Standard for Automotive Lifts – Safety Requirements for Operation, Inspection and Maintenance; and the employer shall ensure that lift inspectors are qualified and that they are adequately trained in the inspection of the lift.
- Shall establish procedures to periodically maintain the lift in accordance with the lift manufacturer's instructions or ANSI/ALI ALOIM, Standard for Automotive Lifts – Safety Requirements for Operation, Inspection and Maintenance; and the employer shall ensure that lift maintenance personnel are qualified and that they are adequately trained in the maintenance of the lift.
- Shall maintain the periodic inspection and maintenance records recommended by the manufacturer or ANSI/ALI ALOIM, Standard for Automotive Lifts – Safety Requirements for Operation, Inspection and Maintenance.
- Shall display the lift manufacturer's operating instructions; ALI/SM, "Lifting It Right" safety manual; ALI/ST, "Safety Tips" card; ANSI/ALI ALOIM, Standard for Automotive Lifts – Safety Requirements for Operation, Inspection and Maintenance; ALI/WL Series, ALI Uniform Warning Label Decals/Placards; and in the case of frame engaging lifts, ALI/LP-Guide, "Quick Reference Guide – Vehicle Lifting Points for Frame Engaging Lifts"; in a conspicuous location in the lift area convenient to the operator.
- Shall review and understand the proper requirements outlined in ANSI/ALI ALIS, Safety Requirements for Installation and Service of Automotive Lifts.
- Shall consult with a qualified person to address seismic loads and other local or state requirements.

GENERAL REQUIREMENTS & LIFT SPECIFICATIONS

10,000 lb. Capacity (2,500 lbs. per lift pad)

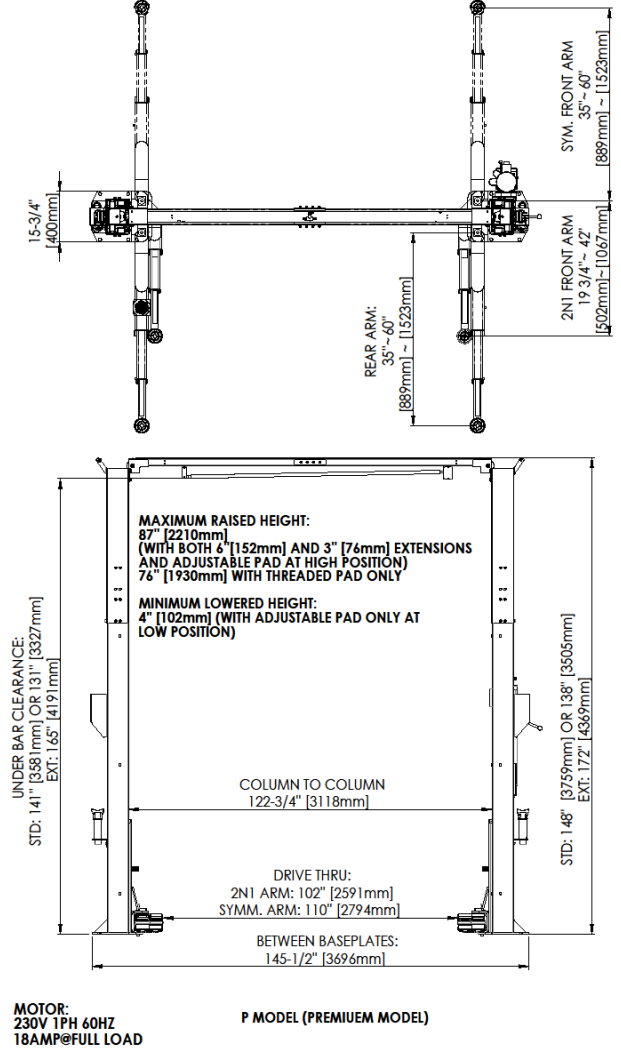
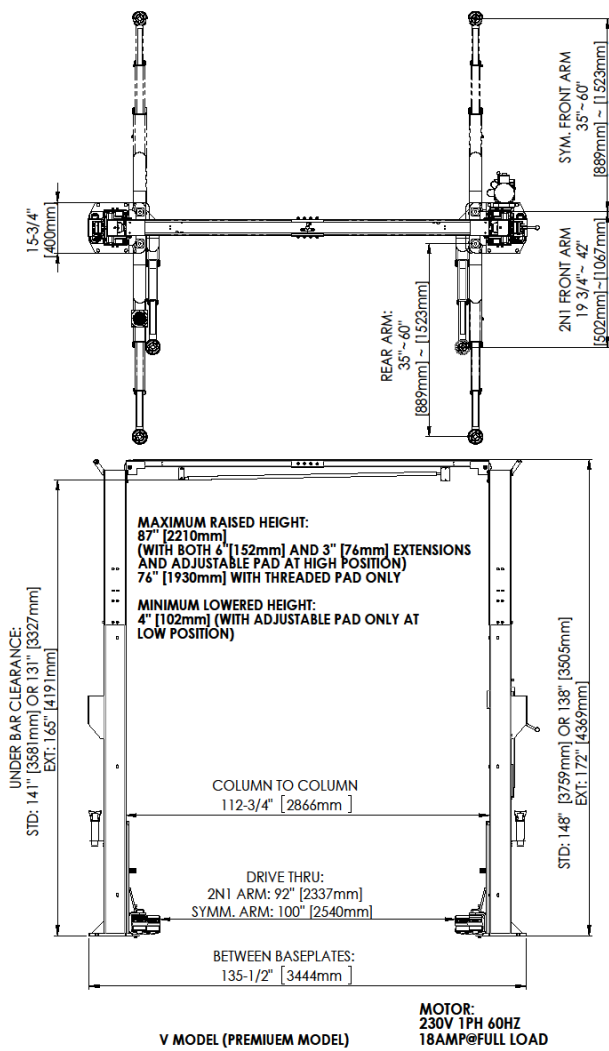

Lift should only be installed on level concrete floors with a minimum of 4 inches (102mm) and 3000 psi (20.7MPa) concrete that has been aged a minimum of 30 days. A qualified person should be consulted to address seismic loads and other local or state requirements.

A constant supply of 230 volt, 1PH, 60Hz, 25 amps electrical is required for this lift.

This lift is designed for INDOOR use only, outdoor installation is prohibited.

BAY CLEARANCE

FRONT OBSTACLE

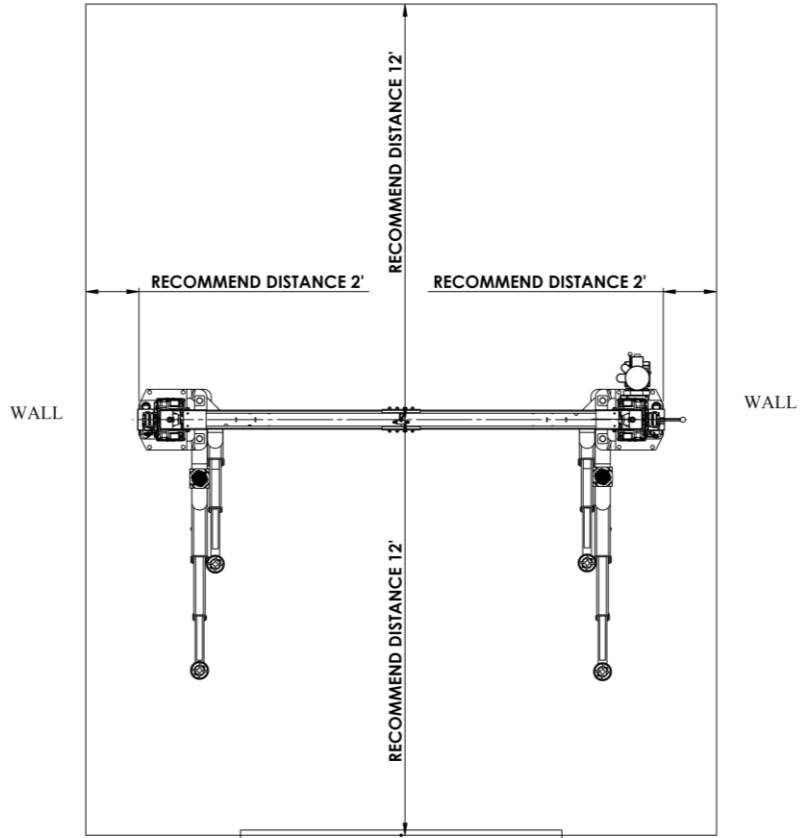

REAR OBSTACLE

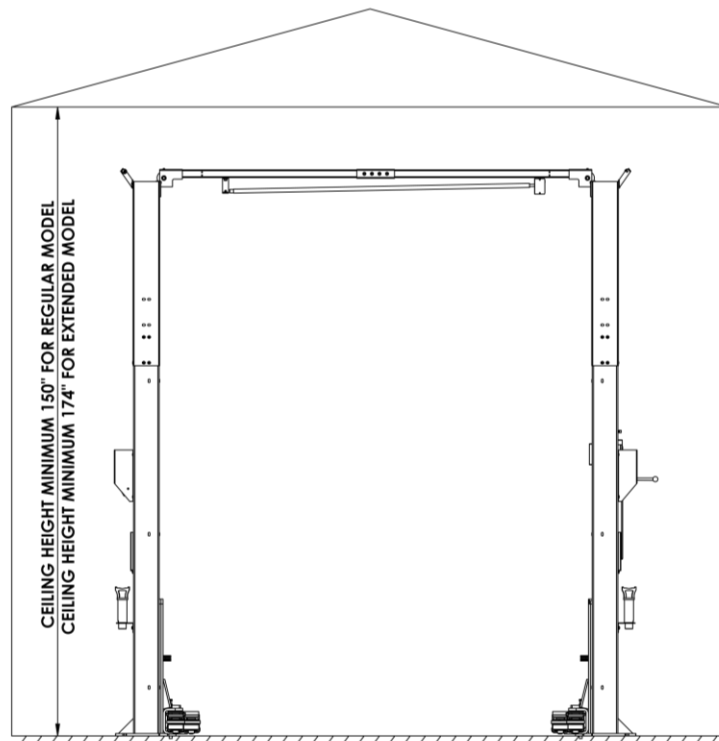

TOOLS REQUIRED & PRE INSTALLATION PROCEDURES

Tools Required

- ✓ 4" x 4" Wooden Blocks (for unpacking)
- ✓ 16ft. Measuring Tape
- ✓ Chalk Line and Chalk
- ✓ Side Cutters
- ✓ Crow Bar
- ✓ Metric & SAE Wrenches and Ratchet Set
- ✓ Metric & SAE Allen Key Sets
- ✓ Hammer & Screwdrivers
- ✓ 12 ft. Step Ladders - 2 (2 people using 12 ft. ladders should install the overhead crossmember assembly)
- ✓ 4 ft. Levels - 2
- ✓ Rotary Hammer Drill with 3/4" diameter Masonry Drill Bit

Pre-Installation Procedures

Before proceeding with installation, read the installation manual and insure all instructions are fully understood and all component parts are accounted for.

1. In the installation area, identify the center line of the bay and mark the floor. Also mark the center of bay entrance door. Connect these two points with a chalk line in the area where lift will be located. Draw a second chalk line at 90° to locate the positions of both lift columns (refer to lift dimensions and bay layout). Insure each lift column is equal distance from bay centerline and each baseplate has a minimum distance of 6" (152mm) from any floor seam. Do not install if floor has cracks or deterioration that could affect lift stability. The shop owner is responsible for confirming there are no obstructions in the installation area like floor drains, under floor piping or electrical conduit that could be damaged or prevent safe lift installation and secure lift anchoring. Check ceiling for beams or heating ducts and walls for protruding structures, etc. Confirm that the overall height and width you intend to install will fit in the bay. Insure the lift can be safely installed in the position you have marked out on the bay floor.
2. Place the lift on wooden blocks so that the steel shipping frames can be removed.
3. Remove protective wrapping. Clear installation area of all packaging materials.
4. Unbolt steel shipping frames and remove from installation area.
5. Carefully remove top column and lay on the floor (carriage side up).
6. Carefully remove column extensions (2 pc), cross-member (3 pc), overhead safety bar, arms (4 pc), powerpack and hardware box from the lower column.
7. Identify powerpack column (reference diagram #1). Move (carriage side up) to appropriate location placing the baseplate end on your floor marks. Similarly, move the second column to the opposite location.

INSTALLATION PROCEDURE

See the Illustration and Parts Reference section of this manual for diagrams and parts lists that will assist you during the installation process. Use these diagrams and parts lists together with the following written instructions. Insure the lift installation complies with ANSI/ALI/ALIS, Safety Requirements for Installation and Service of Automotive Lifts.

1. With columns laying on the ground (carriage side up), tightly fasten one column extension to one column using bolts, washers provided (reference diagram #1). **Use extra washer if necessary to shim bolts to make it flush with inside of tower to clear sliders.** Use the appropriate bolt hole locations to achieve either a 148" (3759mm) or 138" (3505mm) inch overall height. Repeat this procedure with the second column. Note: extended model has 172" (4369mm) overall height.
2. Layout all pieces of the overhead crossmember on the floor and fasten tightly together using bolts, washers and nuts provided (reference diagram #4).
3. Identify all parts for overhead safety shut-off bar (reference diagram #4). Tightly fasten these parts to overhead crossmember with bolts, washers and nuts provided.
4. Raise each column so that its baseplate is located on the floor marking you made earlier. Confirm that baseplate angles and measurements between columns match lift specifications. **Use extreme caution to insure the columns do not fall over.** Secure baseplate of the most level column by installing **only one** anchor bolt.
5. For optimum safety, two installers should lift and secure the overhead crossmember to both columns using bolts, washers and nuts provided (reference diagram #4). Hand tighten all crossmember nuts and bolts. Final tightening is completed in step 9.
6. Using two 4 ft. levels and required shims, level each column vertically on all four sides (reference diagram #5). **Use extreme caution to insure the columns do not fall over. IMPORTANT:** When leveling each column using anchor bolts provided, do not use more than 3/4 inch (19 mm) of shims under any area of the baseplate. Use a 4 ft. level to confirm the overhead crossmember is also level and at 90 degrees to both columns.
7. Drill and install all anchor bolts, washers and nuts (reference diagram #5). Insure that each nut is torqued to 150 ft-lbs (204N-m). ***This should be checked monthly.***
8. One equalizing cable comes partially installed on each carriage. Before feeding a cable up its column to the overhead crossmember, insure the cable is properly seated around the lower pulley at the base of each column (reference diagram #6). Route each cable up its column, over the appropriate pulleys in the overhead crossmember, and lower it down to the opposite carriage. Insure both equalizing cables are properly seated in overhead crossmember pulleys. Thread one nut to its farthest point on each equalizing cable. Insert threaded end into appropriate location on the carriage. Install and hand tighten second nut to secure each cable. Final equalizing cable adjustment is step 17. Install two bolts and nuts to prevent unintentional cable displacement.
9. Completely tighten both sides of the overhead crossmember to its column.

10. Identify component parts for the safety release cable. Install safety release cable so that safety locks in both columns will completely disengage when lift is lowered. Final safety release cable adjustment is step 16.
11. Identify parts to install arms (reference diagram #11). Install all 4 arms and arm pins. Secure each arm pin by inserting roll pin provided. Adjust arm restraint to make sure it works properly.
12. Install rubber mounts on powerpack bracket (reference diagram #13). Keep these rubber mounts between the powerpack and the mounting bracket
13. Identify parts for hydraulic system installation (reference diagram #12). Tightly fasten hydraulic lines to "T" fitting. Locate "T" assembly in overhead crossmember and route the appropriate lines to cylinders and powerpack. Tightly fasten all hydraulic lines and secure these lines to both columns and overhead crossmember using hardware. Insure that nothing will rub or wear the hydraulic lines.
14. **NOTE: this should be performed by a licenced electrician.** Attach microswitch to overhead safety bar bracket on powerpack side of overhead crossmember. Wire overhead safety bar micro-switch to the powerpack. Wire powerpack to shop electrical system.
15. Fill powerpack reservoir with ISO 32 hydraulic oil. **Make sure black venting plug is attached at the top of the reservoir. Attach red plug at the bottom of the reservoir.**
16. **Operate the lift with no vehicle and no other weight.** Raise lifting carriages approximately 30 inches (760mm). Confirm that safety locks on both sides engage properly while lift is being raised. Verify that both lifting cylinders are properly seated in the baseplate locator hole. Continue raising lift to full height confirming safety locks are engaging. Adjust safety release cable to insure safety locks can be completely disengaged while lowering lift (reference diagram #7). Insure that no people or obstacles are near the lift when adjusting the safety release cable. Lower lift completely. Raise and lower the lift at least three times or until all air in the hydraulic system is removed.
17. After confirming that all air has been bled from the hydraulic system, adjust equalizing cable tension as follows: (also reference diagram #6).

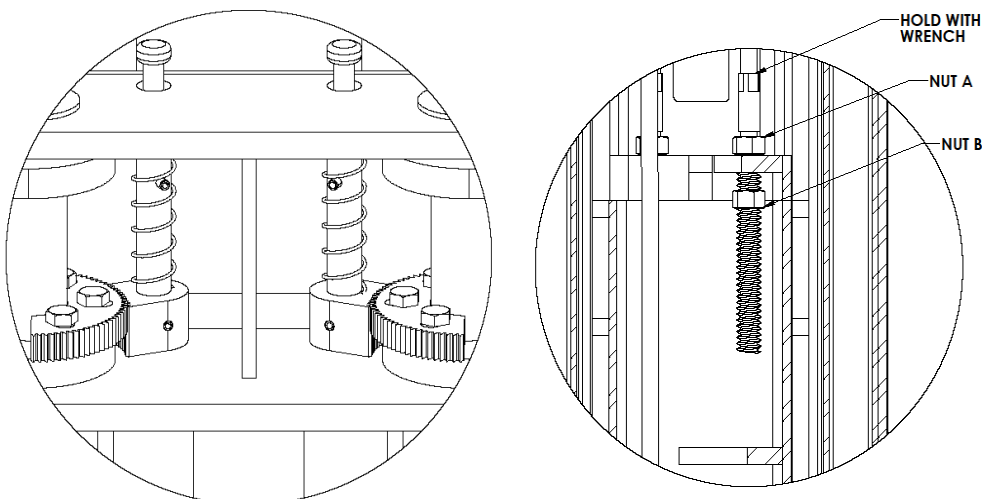

Step 1) Hold top of threaded stud with a wrench to prevent it from rotating.

Step 2) Tighten nut "B" until all loose slack is removed from the cable. Do not over tighten.

Step 3) Firmly tighten nut "A" to lock cable in place. Repeat this process for the other cable insuring both cables have the same degree of tightness.

18. Raise lifting carriages approximately 12 inches (300mm) off the floor. Choose one arm and align arm restraint gear with locking plunger insuring both components mesh smoothly and totally. Completely tighten all arm restraint gear locking bolts to maintain this position. Lower carriage to the floor to insure arm restraint disengages in the down position. Raise the lift 12 inches (300mm) off the floor to insure arm restraint engages smoothly and totally. Repeat this process with the remaining 3 arms. Raise and lower the lift once more to confirm all arm restraints totally engage and disengage smoothly.
19. Install safety lock cover on each column (reference diagram #14).
20. The installation is now complete. **Insure that all lift operators are trained in all points covered by ALI-WL101 label kit (they are applied at the factory).**

Final Checkout Procedure of Assembled Lift

- ✓ **Important: Check if carriage clears hydraulic hoses when fully raised! Fail to do this may cause hydraulic line damage.**
- ✓ Check hydraulic oil level in reservoir. Confirm hydraulic connections are tight with no leaks
- ✓ Confirm that both columns are level and properly shimmed with all anchor bolts torqued to 150 ft.-lbs. (204Nm). Confirm lift stability
- ✓ Confirm that all electrical components have been wired properly and are operational
- ✓ Confirm that all cables are adjusted properly
- ✓ Confirm safety locks and arm restraints are functioning properly
- ✓ Lubricate all lubrication points
- ✓ Check all the functions with a representative vehicle. (follow the instructions "LIFT OPERATIONAL TEST WITH A TYPICAL VECHICLE")

Insure this manual along with all operation, inspection and maintenance instructions are delivered to the owner, user and employer.

OPERATING INSTRUCTIONS & LIFT MAINTENANCE

LIFT OPERATION:

Before lifting a vehicle, insure all operators are qualified, have been trained and are following all safety instructions. Read and follow the ALI "Lifting It Right" manual included with the lift. Always use the "Vehicle Lifting Points" reference guide when lifting a. Insure all materials stay up to date >>> www.autolift.org/ (see example of SAE J2184 standard below)

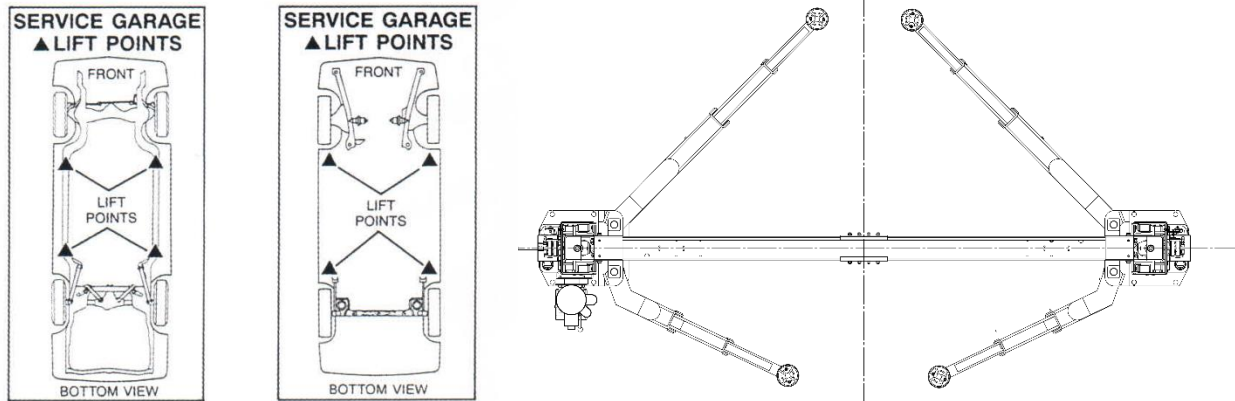

Typical Label Drawings
Reprinted with permission from SAE J2184
©2007 Society of Automotive Engineers, Inc.

Insure the vehicle is securely positioned on the lift using manufacturer's recommended lifting points. Insure all arm restraints are totally engaged. Never allow anyone under the lift when raising or lowering it with or without a vehicle. Always confirm safety locks on both sides of the lift are completely engaged before proceeding under a vehicle.

Lift electrical operating controls are located on the powerpack (one "up" button for raising the lift and one "down" lever for lowering the lift). Before lowering, slightly raise the lifting carriages to release pressure from both safety locks. Two hands must be used when lowering the lift. One hand must operate the safety lock release lever (located on the column above the powerpack) and one hand must operate the "down" lever. Make certain the safety locks do not accidentally re-engage while lift is being lowered. Customers and bystanders should not be in the lift area.

Important: Regularly inspect the hydraulic pressure developed upon the rated capacity, and make sure the pressure doesn't exceed the operating pressure (2,100 psi).

LIFT OPERATIONAL TEST WITH A TYPICAL VEHICLE:

To Raise Vehicle

1. Lower carriages to the floor position.
2. Retract lifting arms to minimum length.
3. Swing arms away from the path of the vehicle.
4. During loading or spotting, center the vehicle between the columns as shown in figure above.
5. Swing arms under the vehicle. Position the vehicle support pads at the VEHICLE MANUFACTURES RECOMMENDED LIFTING POINTS. Beginning with some 1994 year models, auto makers will identify recommended lift points by placing a label on the vertical lock face plate of the front passenger side door. (ANSI/SAE J2184-OCT92)
6. Clear area around the lift.
7. Raise the vehicle until the vehicle support pads are in full contact, approximately 12 inches (300mm) off floor. Check to see that vehicle is stable on the lift by moderately rocking the bumper. Recheck the position of the pads for any movement.
8. Raise the vehicle to the desired working elevation and release control button.
9. Lower lifting carriages until they completely contact the mechanical safety locks. The vehicle is now ready for service.

To Lower Vehicle

WARNING: No one shall be under the vehicle when lowering.

1. Clear area around and under the lift of obstructions and warn personnel to stand clear.
2. Raise vehicle by at least 3 inches (76mm).
3. Pull the safety cable release lever **all the way down**.
4. While keep the safety release lever pulled, push lower lever on the power unit to lower the lift.
5. Lower the lift until arms have bottomed and are clear of the lifting points.
6. Swing the lifting arms from beneath the vehicle and fully retract the arms.
7. Remove the vehicle.

To Load an unusual Vehicle

Call factory for technical support with vehicle spec before loading.

LIFT MAINTENANCE SCHEDULE

Before maintaining, servicing or repairing the lift, insure that an acceptable "**lock out/tag out**" device is activated. The following minimum maintenance schedule must be performed by the owner or lift operator.

DAILY

- ✓ Raise and lower the lift without vehicle to verify operations and carriage levels.
- ✓ Confirm all arm restraints engage and disengage smoothly and totally and telescoping arms have no excessive movement.
- ✓ Check all hydraulic fittings and lines for damage or leaks.
- ✓ Check electrical wiring for damage.
- ✓ Check all moving parts for uneven or excessive wear.
- ✓ Repair or replace all damaged, worn, or broken components immediately.
- ✓ Remove oil/grease on all lift pads.

WEEKLY

- ✓ Check hydraulic fluid in powerpack reservoir. (Confirm no leaks before topping up)
- ✓ Check equalizing cable adjustment. Check safety lock release cable adjustment.

MONTHLY

- ✓ Check that all anchor bolts are torqued to 150 ft.-lbs. (204N-m).
- ✓ Clean and lubricate arm restraints. (Confirm all components are in good condition)
- ✓ Lubricate safety locks in both columns.
- ✓ Check that overhead safety shutoff is operating properly.

EVERY TWO MONTHS

- ✓ Remove and grease arm pins – reinstall insuring secure fit.
- ✓ Clean and re-grease slide block channel in both columns.
- ✓ Clean and lubricate all cable pulleys.

EVERY YEAR

- ✓ Arrange for a Trained Lift Service Person to inspect and certify all aspects of the lift as per "Automotive Lift Operation, Inspection and Maintenance" (ALOIM) guidelines.
- ✓ Confirm that both equalizing cables meet the standard outlined on page 13.

EVERY TWO YEARS

- ✓ Change and replace hydraulic oil in powerpack reservoir.

LUBRICATION

- ✓ Where grease is required use a multi-purpose lithium grease
- ✓ Where lubricating oil is required use WD-40 or a SAE 30 oil
- ✓ Where hydraulic oil is required use ISO 32 – 10W non detergent hydraulic oil.

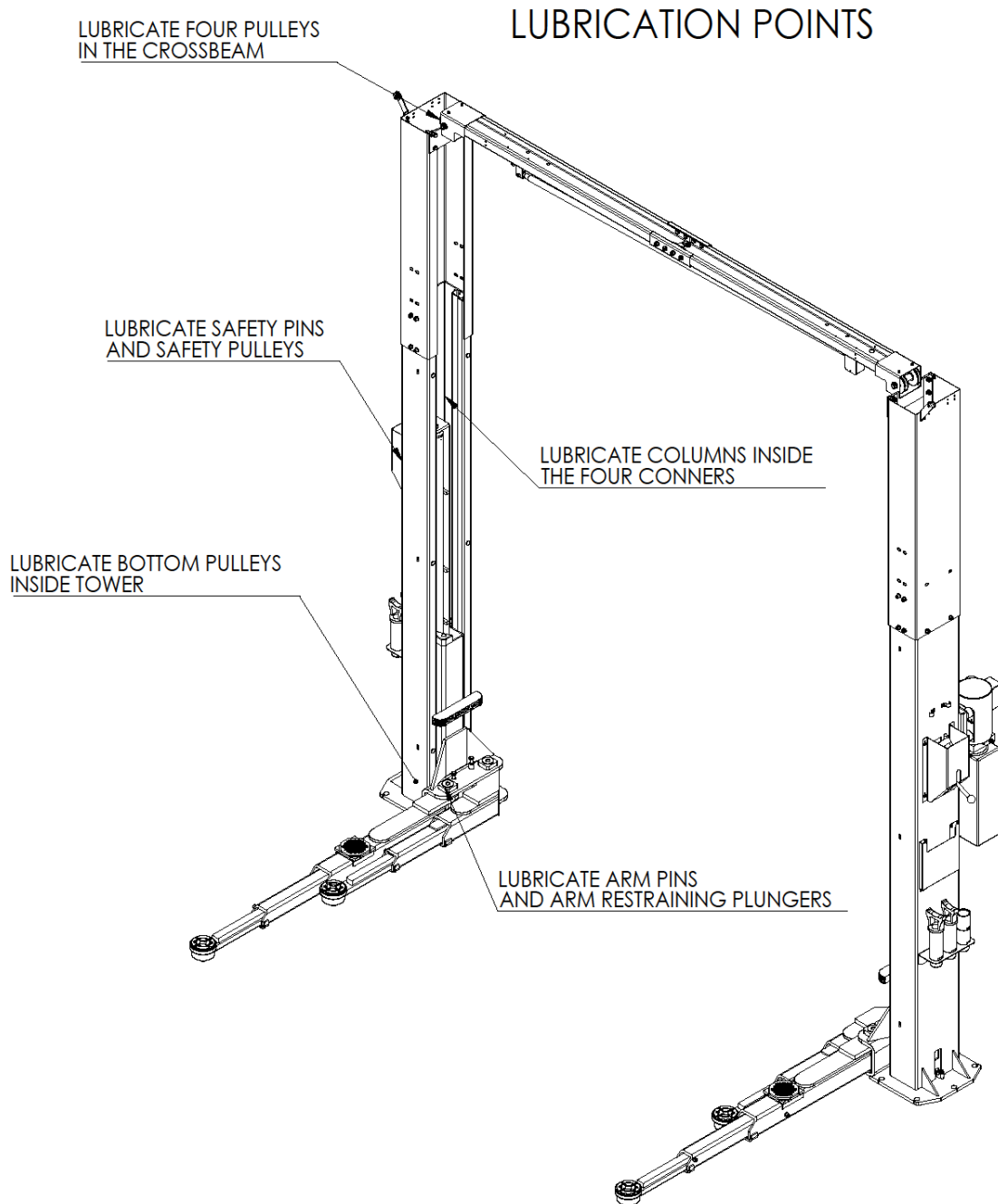

Cable Inspection

The following criteria will determine when an equalizing cable is no longer acceptable for service:

- 12 randomly distributed broken wires in one lay or four broken wires in one strand in one lay in running ropes
- one outer wire broken at the contact point with the core of the rope, which has worked its way out of the rope structure and protrudes or loops out from the rope structure
- wear of one-third the original diameter of outside individual wires
- kinking, crushing, birdcaging, or any other damage resulting in distortion of the rope structure
- evidence of heat damage from any cause
- reduction from nominal diameter greater than those listed in the following table:

Rope Diameter	Max. Allowable Reduction
5/16" (8 mm) or less	1/64" (0.4 mm)
5/16" (8 mm) to 1/2" (12 mm)	1/32" (0.8 mm)
1/2" (12 mm) to 3/4" (19 mm)	3/64" (1.2 mm)

- Attention shall be given to end connections. Upon development of two broken wires adjacent to socket end connections, the rope shall be re-socketed or replaced. Re-socketing shall not be attempted if the resulting rope length will be insufficient for proper operation.
- If any of the cable is as shown in the following pictures, do not use.

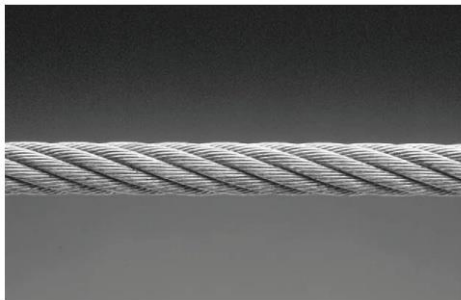

Typical Good Cable

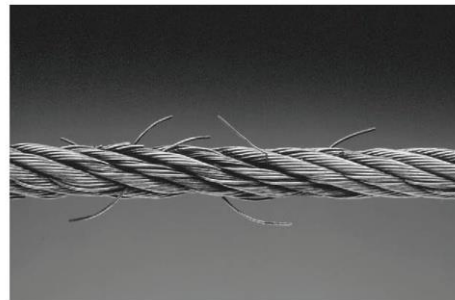

Cable With Broken Wires

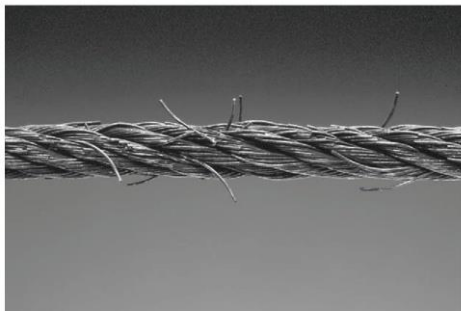

Cable With Severe Corrosion

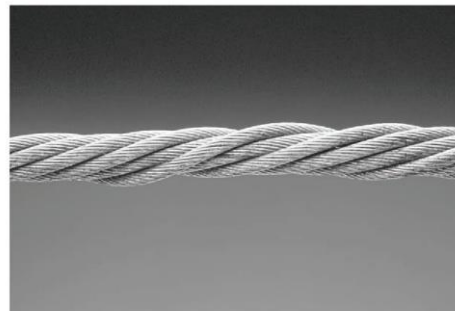

Cable With Necking

LIFT PROBLEM TROUBLESHOOTING GUIDE

The following are some suggestions to consider if problems are encountered with the lift. Please call a Trained Lift Service Person for further clarification and information.

- **Lift does not operate:** Possibilities include: blown fuse or tripped circuit breaker, defective "up" button. Call a qualified electrician for all wiring questions.
- **Motor runs but lift does not rise:** Possibilities include: low hydraulic oil level (check reservoir tank), dirt under check valve (press "down" lever and "up" button at the same time for 10-15 seconds. This will clear small contaminants. If this fails clean check valve ball and seat by removing valve cover). Call a Trained Lift Service Person if problem continues.
- **Motor noise (drone or hum) but will not run:** Possibilities include: low voltage, faulty wiring or faulty capacitor (call electrician to confirm), lift is overloaded (insure vehicle weighs less than rated lift capacity).
- **Lift falters or jerks when it is raised or lowered:** Possibilities include: air in the hydraulic system, cycle lift all the way to the top and completely lower 3 – 4 times. If this does not solve the problem call a Trained Lift Service Person.
- **Excessive noise when raising or lowering lift:** Possibilities include: pulley assemblies need lubricating, cable is off the pulleys, carriage sliders need grease, carriage sliders are broken. Do not operate the lift with broken or damaged carriage sliders or dislodged cable. Replace immediately.
- **Lifting carriages are unequal when raised:** Possibilities include: improperly adjusted equalization cables, air in the hydraulic system. Adjust cables or call a Trained Lift Service Person to correct the problem.

NOTE: Replace all worn or broken parts and components only with manufacturer approved/supplied parts and components

Replacement parts may be purchased from your local lift supplier or the manufacturer at 1 - 877 - 799 - LIFT (5438) or (905) 847 - 1198

LIFT ILLUSTRATIONS & PARTS LISTS

The diagram below identifies main component parts and the order in which they are to be installed. Numbers correspond to installation diagrams found in the chart below and on following pages. These diagrams, along with related parts lists, will assist you when installing and servicing this lift. Please insure these lift diagrams and parts lists are kept in a secure place for quick reference.

Diagram #1: LIFT COLUMNS AND COLUMN EXTENSIONS

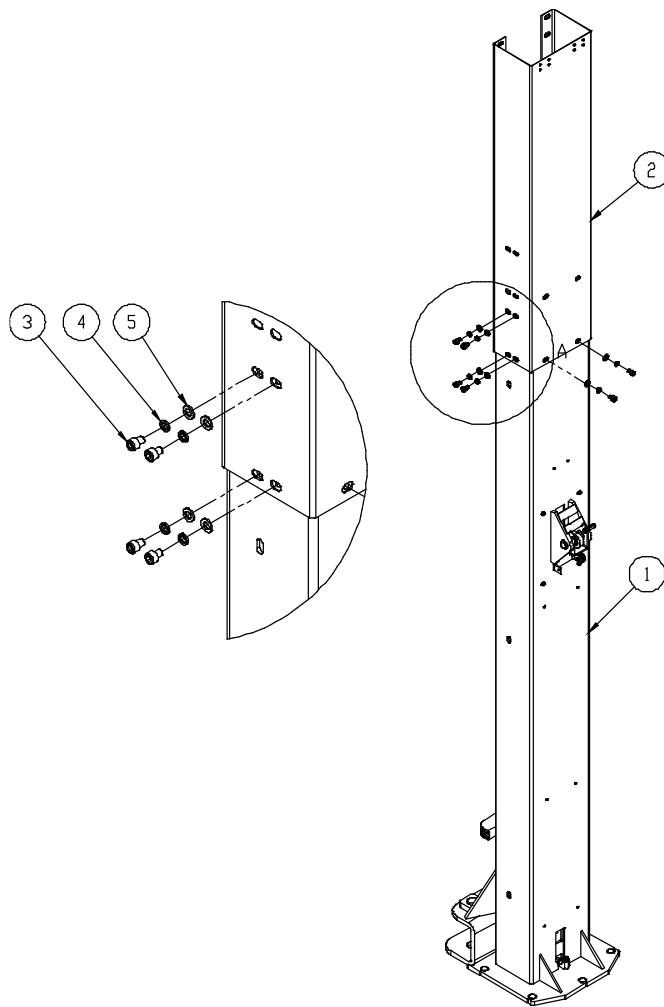

Item	Part Number	Description	Qty
1	42100002	Power side Tower	1
	42100003	Non-Power Side Tower	1
2	12100016	Standard Tower Extension	2
	12100594	Extended Tower Extension	2
3	3C200035	M10X12 Socket Cap Screw	20
4	3C200020	10MM Lock Washer	20
5	3C200011	10MM Flat Washer	20

Diagram #2: LIFT TOWER ASSEMBLY

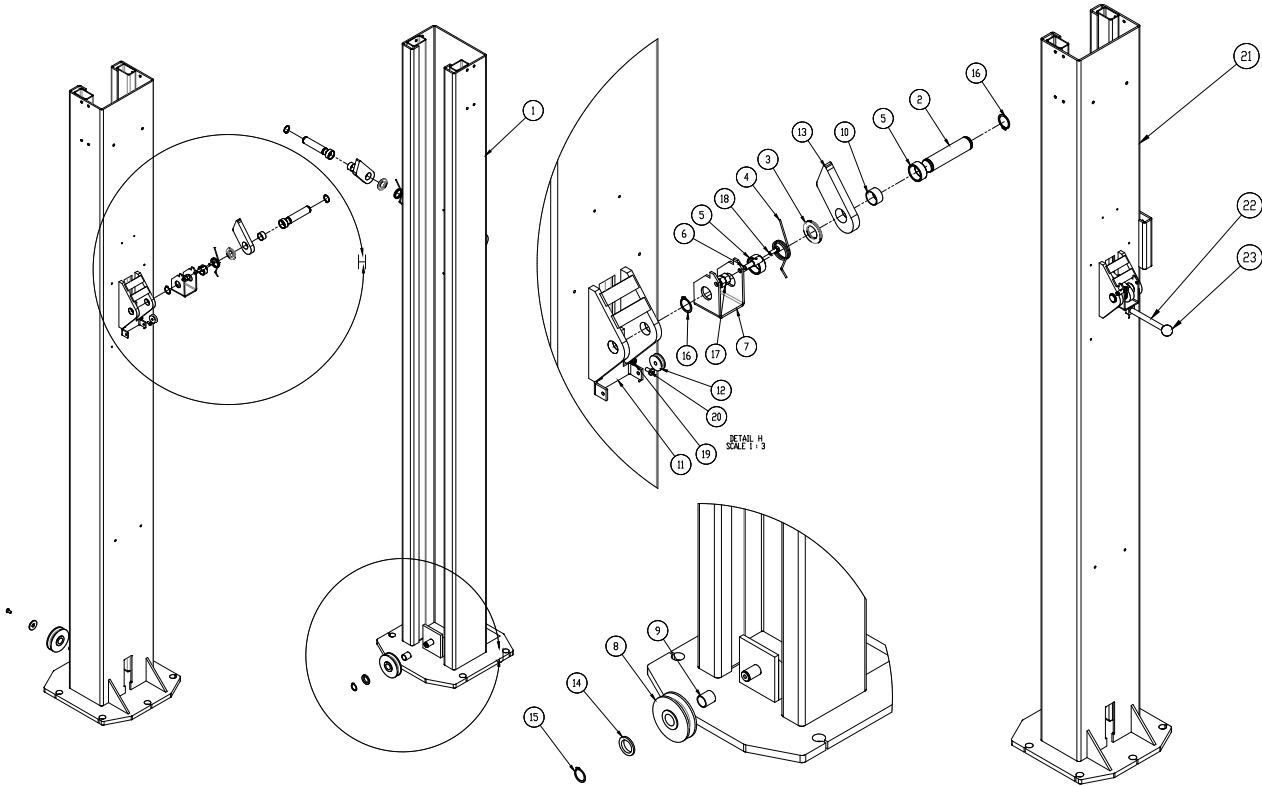

Item	Part Number	Description	Qty
1	22100032	Non-Power Side Tower Weldment	1
2	12100018	Safety Shaft	2
3	32100032	24MM Flat Washer	2
4	12100078	Torsion Spring	2
5	12100020	Spacer	4
6	12100021	Safety Release Cable Clamp	2
7	12100022	Lock Release Channel (Non-power side)	1
	22100035	Lock Release Channel Weldment (Power side)	1
8	12100098	Equalizing Pulley	6
9	32100004	Bushing	2
10	32100005	Bushing	2
11	12100023	Safety Release Pulley Mount	1
12	12100044	Safety Pulley	3
13	12100086	Safety Lock	2
14	32100551	Thrust Washer	2
15	32100537	20MM Snap Ring	2
16	32100538	25MM Snap Ring	4
17	32100539	M8 Nut	4
18	32100540	M6 Bolt	2
19	32100541	6MM Washer	2
20	32100542	M6 Screw	2
21	22100031	Power Side Tower Weldment	1
22	12100025	Lever	1
23	32100040	Plastic Ball	1

Diagram #3: CARRIAGE ASSEMBLY

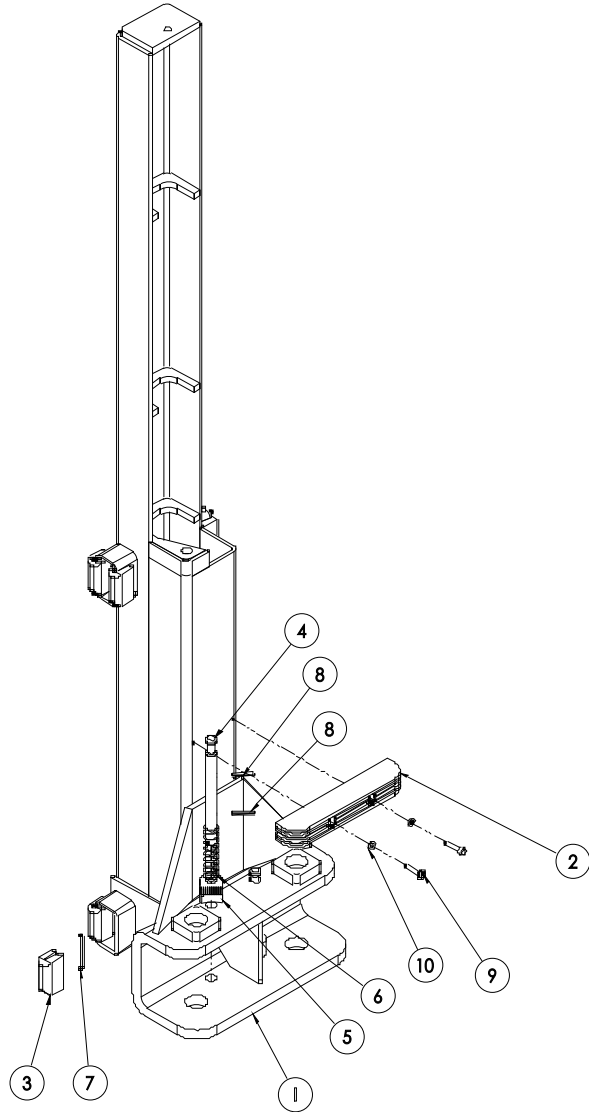

Item	Part Number	Description	Qty
1	22100011	Carriage Weldment	2
2	12100145	Door Guard	2
3	12100027	Carriage Slider	16
4	12100028	Arm Lock Plunger	4
5	12100029	Arm Lock (Inner Gear)	4
6	12100030	Arm Lock Spring	4
7	12100081	Slider Shim	16
8	32100533	Roller Pin	8
9	32100534	M8 Bolt	4
10	32100535	8MM Washer	4

Diagram #4: OVERHEAD CROSSMEMBER ASSEMBLY

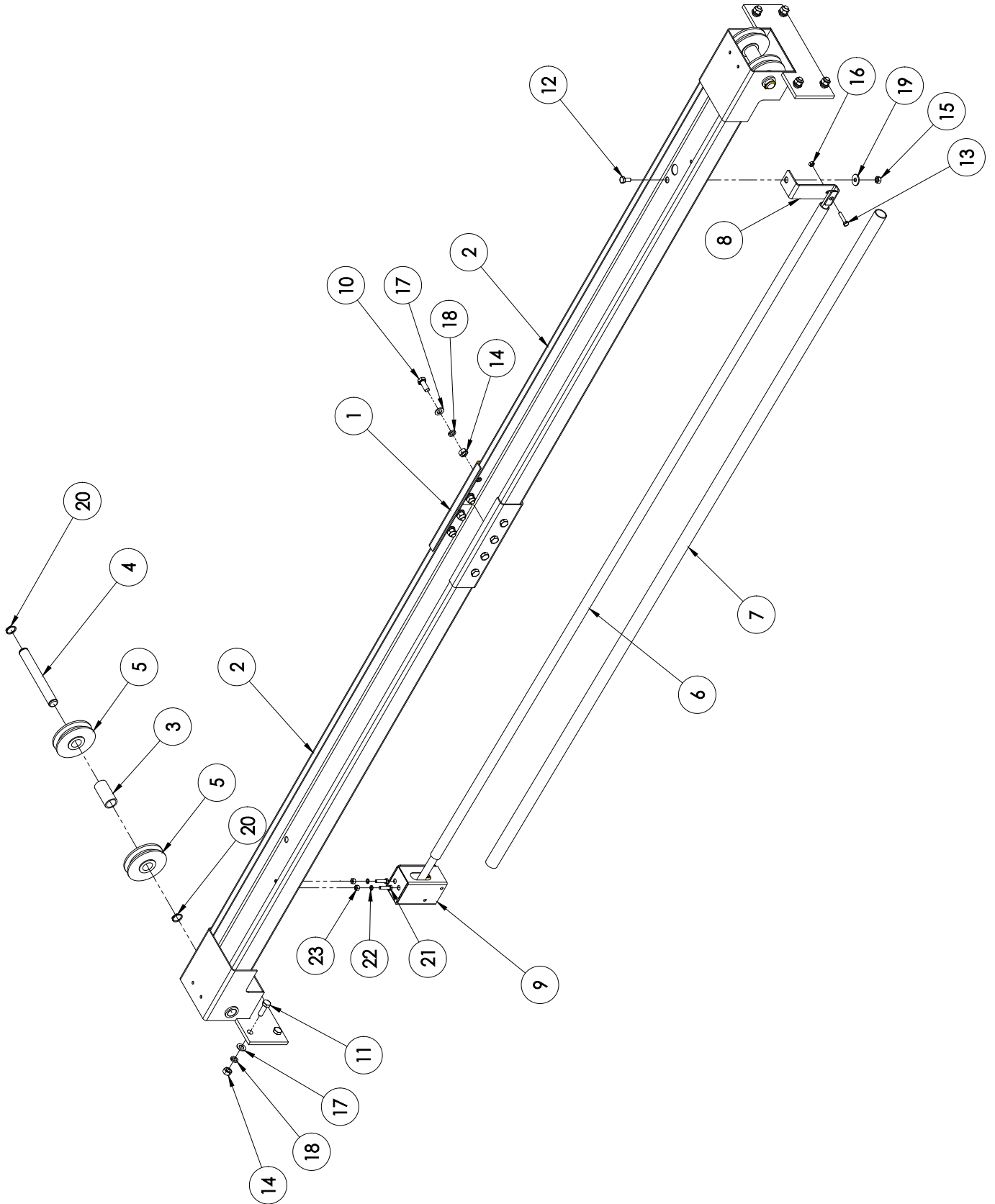

Item	Part Number	Description	Qty
1	12100095/12100231	Standard/Wide Overhead Channel Brace	1
2	22100037	Half Crossbeam Weldment	2
3	12100096	Pulley Spacer	2
4	12100097	Overhead Pulley Shaft	2
5	12100098	Equalizing Pulley	6
6	22100014	Overhead Shut-off Bar	1
7	12100103	Foam	1
8	12100102	Overhead Shut-off Mounting Bracket	1
9	42100010	Overhead Shut-off Micro Switch	1
10	32100530	M10X25 Bolt	8
11	32100531	M10X30 Bolt	8
12	32100020	M8X16 Bolt	1
13	32103035	M6 Bolt	1
14	32100532	M10 Nut	16
15	32100027	M8 Nut	1
16	32103036	M6 Nut	1
17	32100506	10MM Flat Washer	16
18	32100507	10MM Lock Washer	16
19	32100044	10MM Flat Washer	1
20	32100034	20MM Retaining Ring	4
21	32100025	M6X25 Bolt	2
22	32100026	6MM Lock Washer	2
23	32103026	M6 Nut	2

Diagram #5: LIFT LEVELLING - COLUMN SHIMING - ANCHOR BOLTS

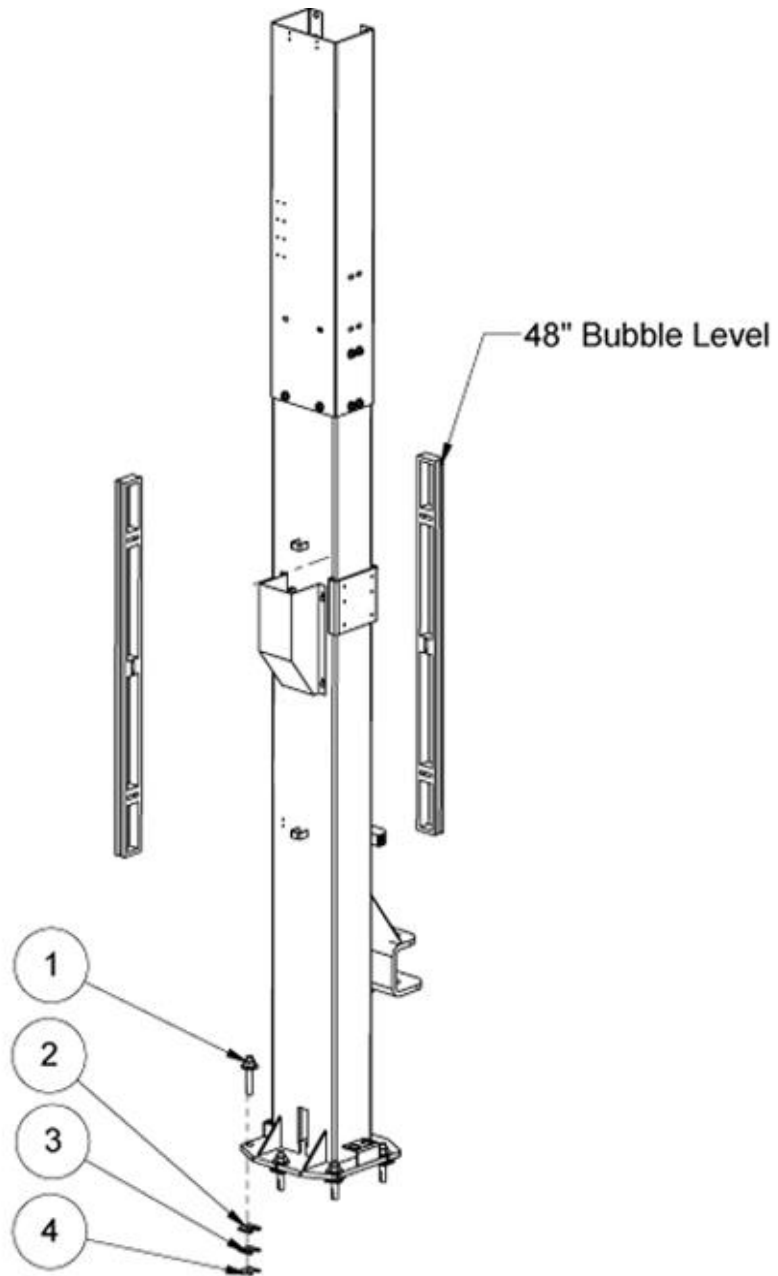

Item	Part Number	Description	Qty
1	3000539	3/4" Concrete Anchor	10
2	3000540	Shim-6mm	10
3	3000541	Shim-3mm	10
4	3000542	Shim-1mm	10

Diagram #6: EQUALIZING CABLES

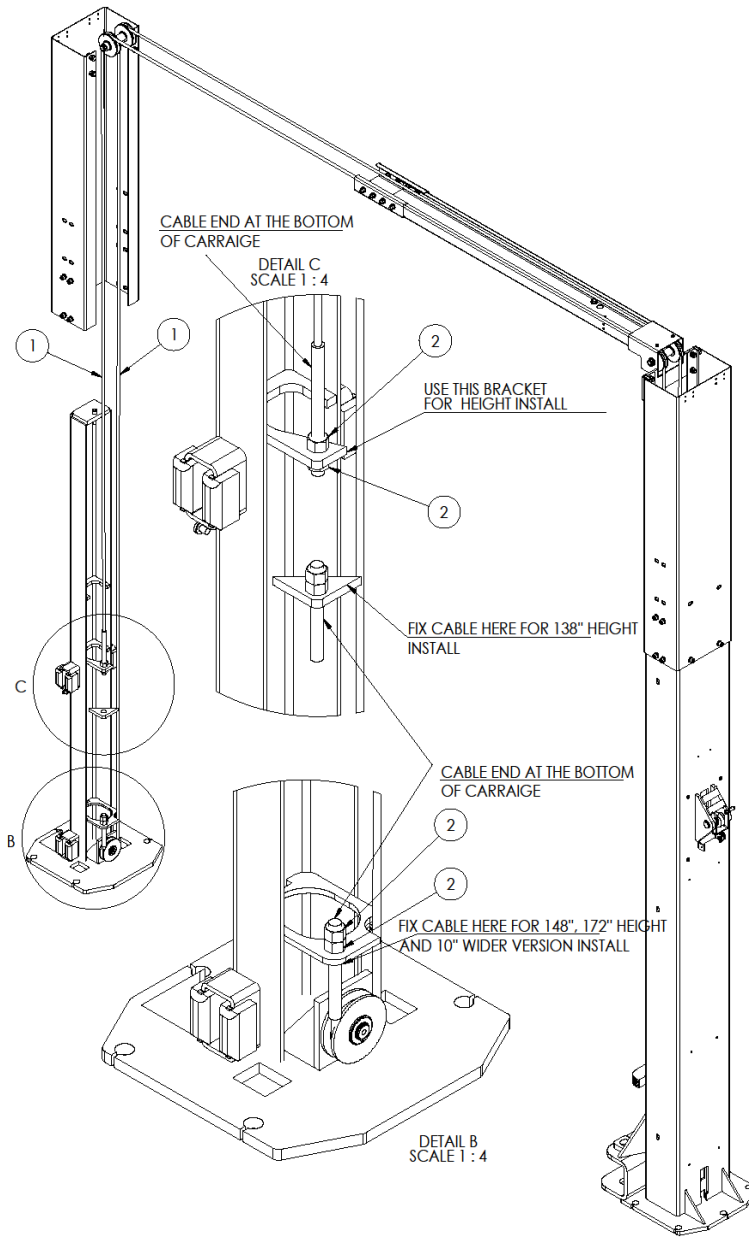

Item	Part Number	Description	Qty
1	32100000	Equalizing Cable, V model, Regular Height	2
	32100070	Equalizing Cable, V model, Extended Height	2
	32100060	Equalizing Cable, P model, Regular Height	2
	32100069	Equalizing Cable, P model, Extended Height	2
2	32100038	M16 Nut	8

Diagram #7: SAFETY RELEASE CABLE

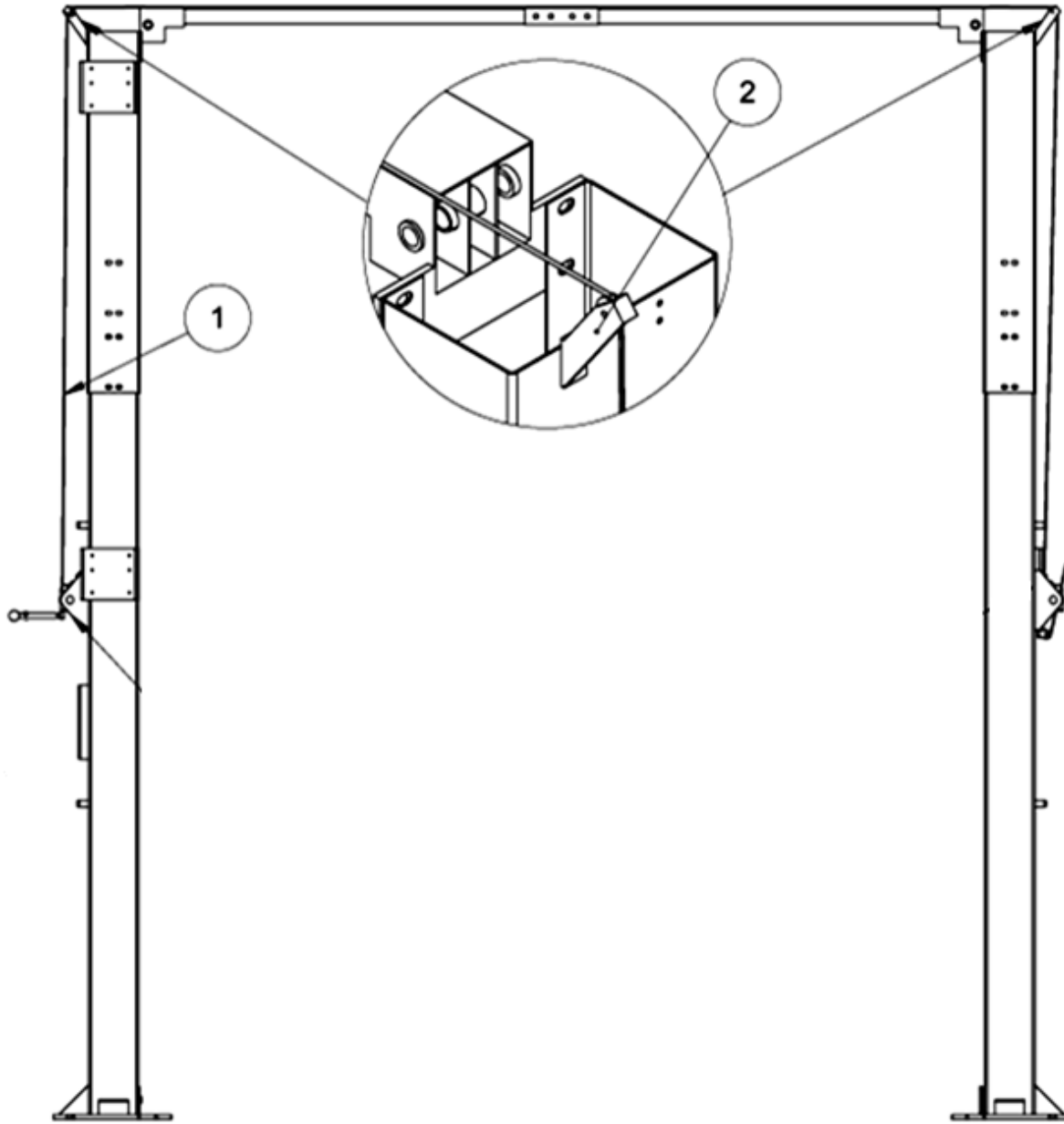

Item	Part Number	Description	Qty
1	32100001/12100593	Safety Release Cable/Extended Model Cable	1
2	42100033	Safety Cable Guide Assembly	2

Diagram #8: SAFETY CABLE GUIDE ASSEMBLY

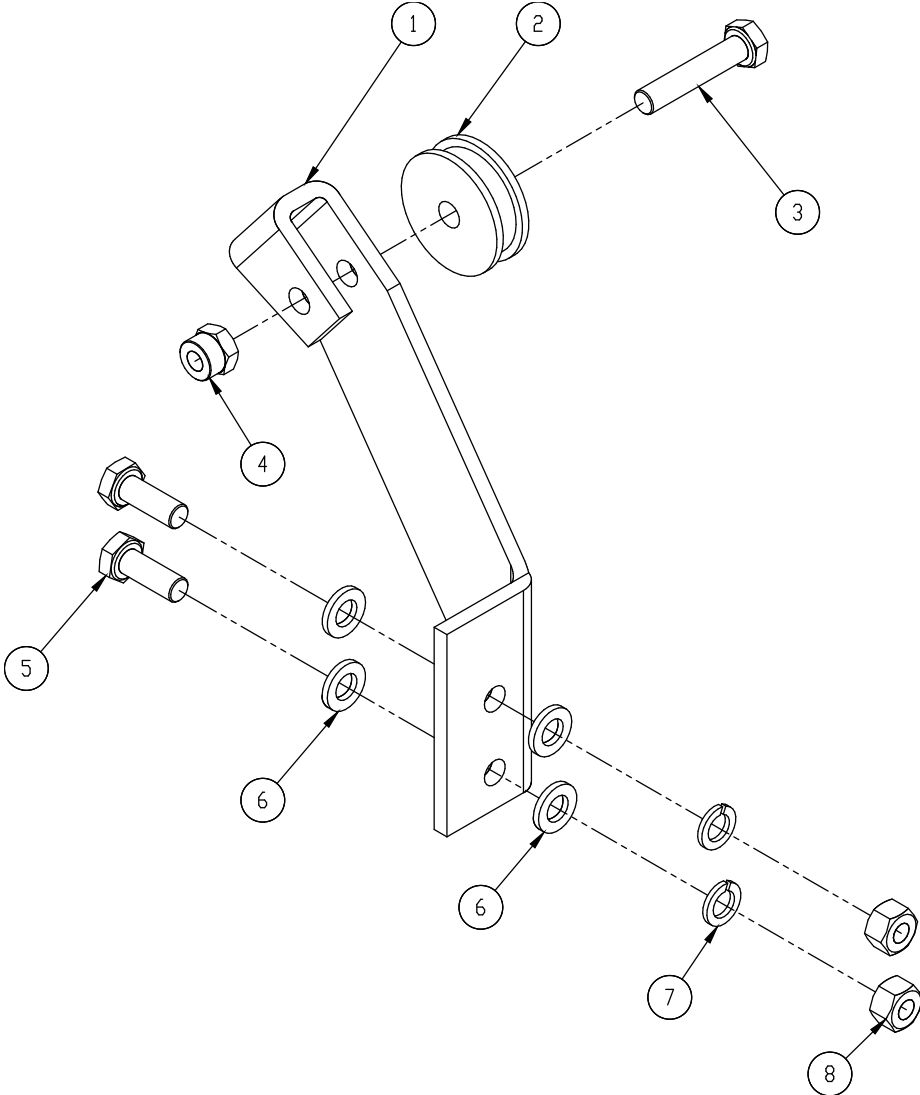

Item	Part Number	Description	Qty
1	12100024	Pulley Bracket	2
2	12100044	Safety Release Pulley	3
3	3C200025	M6X30 Bolt	2
4	3C200029	M6 Lock Nut	2
5	3C200050	M6X20 Hex Bolt	4
6	3C200024	6MM Washer	8
7	3C200027	6MM Lock Washer	4
8	3C200026	M6 Nut	4

Diagram #9: LIFT ARMS AND ARM RESTRAINTS

Diagram #9-1 Front Arm (Driver Side: 42105004, Passenger Side: 42105003)

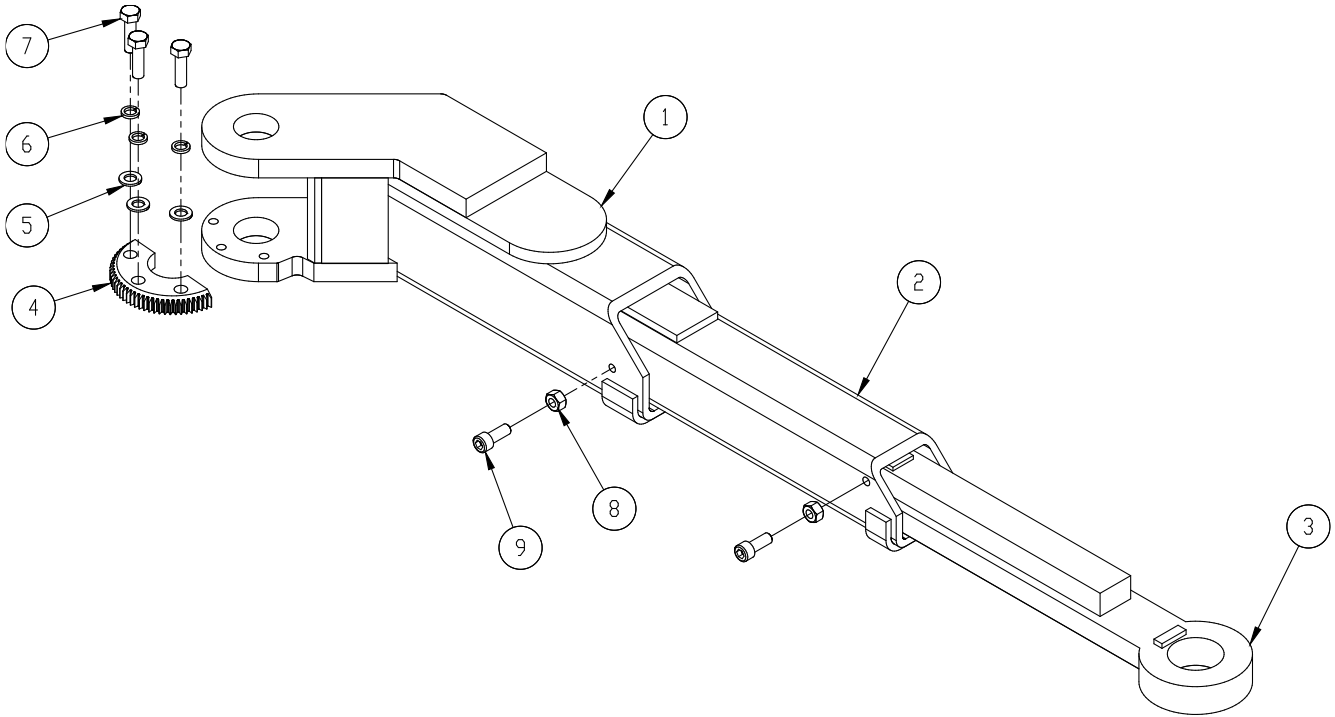

Item	Part Number	Description	Qty
1	22105005	Driver Side Front Outer Arm Weldment	1
	22105003	Passenger Side Front Outer Arm Weldment	1
2	22105006	Driver Side Front Middle Arm Weldment	1
	22105002	Passenger Side Front Middle Arm Weldment	1
3	22105007	Driver Side Front Inner Arm Weldment	1
	22105001	Passenger Side Front Inner Arm Weldment	1
4	12100050	Arm Lock Gear	4
5	3C200011	10MM FLAT WASHER	12
6	3C200020	10MM LOCK WASHER	12
7	3C200018	M10X35 HEX BOLT	12
8	3C200012	M10 NUT	8
9	3C200019	M10X25 SOCKET SCREW	8

Diagram #9-2 Rear Arm (Driver Side: 42105001, Passenger Side: 42105002)

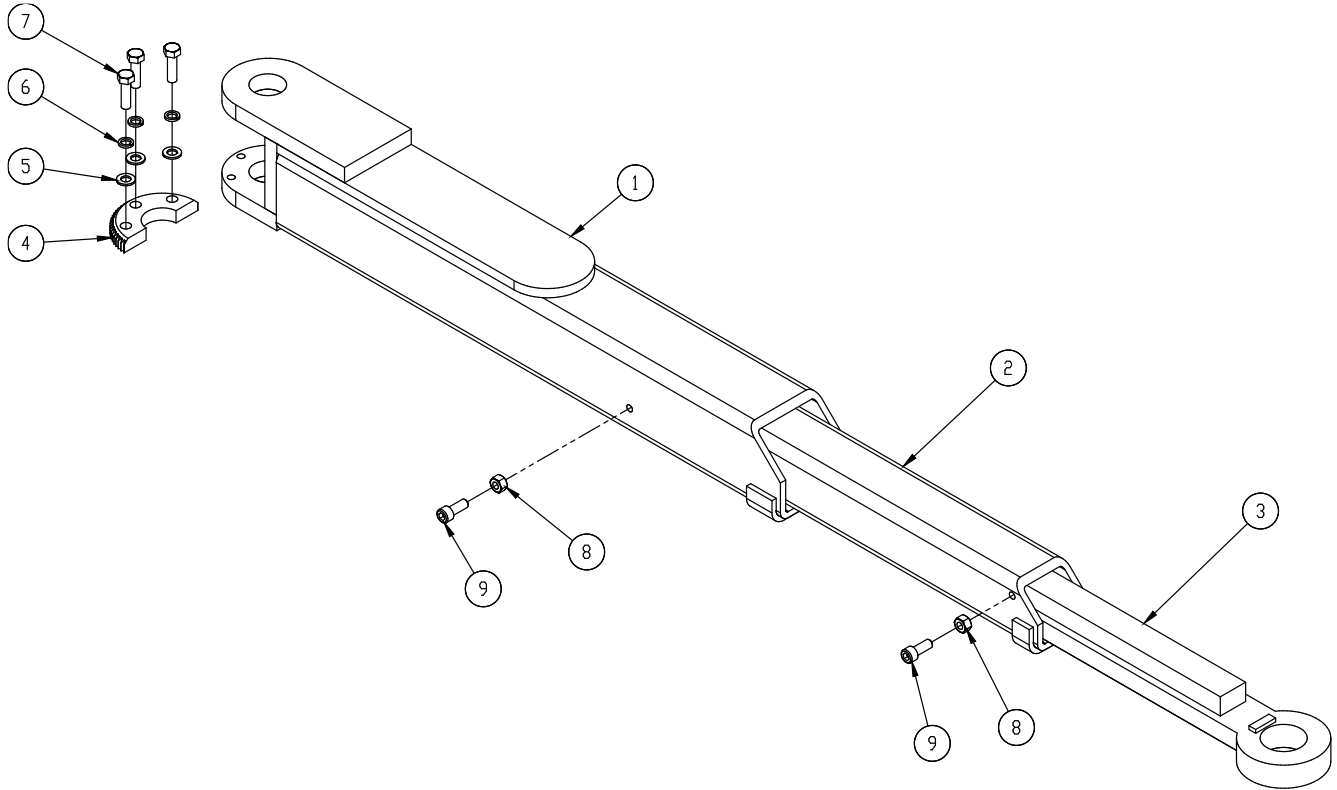

Item	Part Number	Description	Qty
1	22100039	Driver Side Rear Outer Arm Weldment	1
	22100040	Passenger Side Rear Outer Arm Weldment	1
2	22105015	Driver Side Rear Middle Arm Weldment	1
	22105016	Passenger Side Rear Middle Arm Weldment	1
3	22105014	Driver Side Rear Inner Arm Weldment	1
	22105013	Passenger Side Rear Inner Arm Weldment	1
4	12100050	Arm Lock Gear	4
5	3C200011	10MM FLAT WASHER	12
6	3C200020	10MM LOCK WASHER	12
7	3C200018	M10X35 HEX BOLT	12
8	3C200012	M10 NUT	8
9	3C200019	M10X25 SOCKET SCREW	8

Diagram #9-3 Arm Accessories

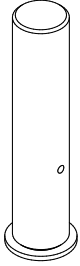

4X 22100027
ARM PIN

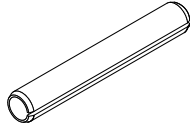

4X 3C200007
6MMX40MM ROLLER PIN

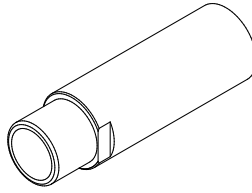

4X 12105101, 6" EXTENSION

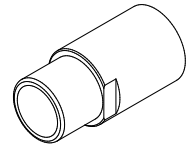

4X 12105102, 3" EXTENSION

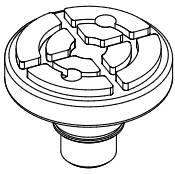

4X 42100036
THREADED LIFTING PAD

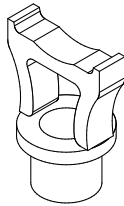

4X 22105008
TRUCK ADAPTER

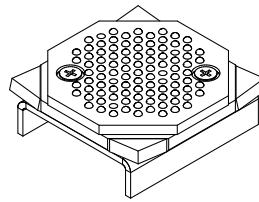

2X TLS2PHA
HONDA ADAPTER

Diagram #9-4 Arm Pin and Lifting Pad Installation

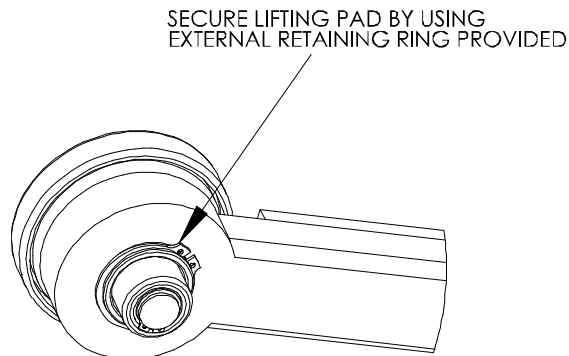
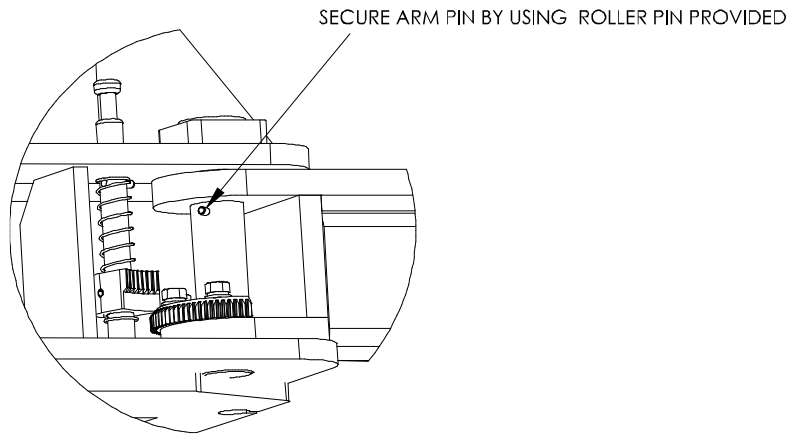
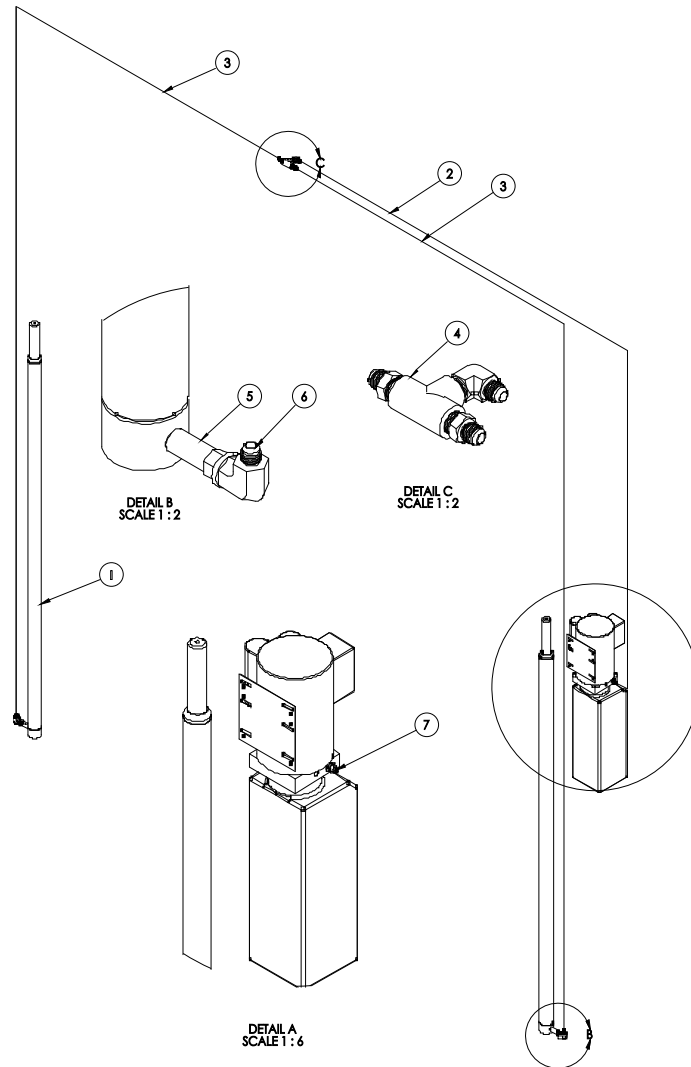

Diagram #10: HYDRAULICS



Item	Part Number	Description	Qty
1	42104007	Hydraulic Cylinders	2
2	32100047	Hydraulic Hose (short)	1
3	32100046	Hydraulic Hose (long)	2
4	32100048	T- Fitting Assembly	1
5	32100049	Flow Restrictor	2
6	32100050	Elbow Fitting	2
7	3H000001	Pump Fitting	1
*8	32100057	10" (254mm) Hose Extension (Not shown on the picture)	1

*Hydraulic hose length varies for **extended** model. For P regular height model, add a 10" (254mm) (32100057) hydraulic hose between item 3 (non power side hydraulic hose) and 4.

Diagram #11: POWERPACK INSTALLATION

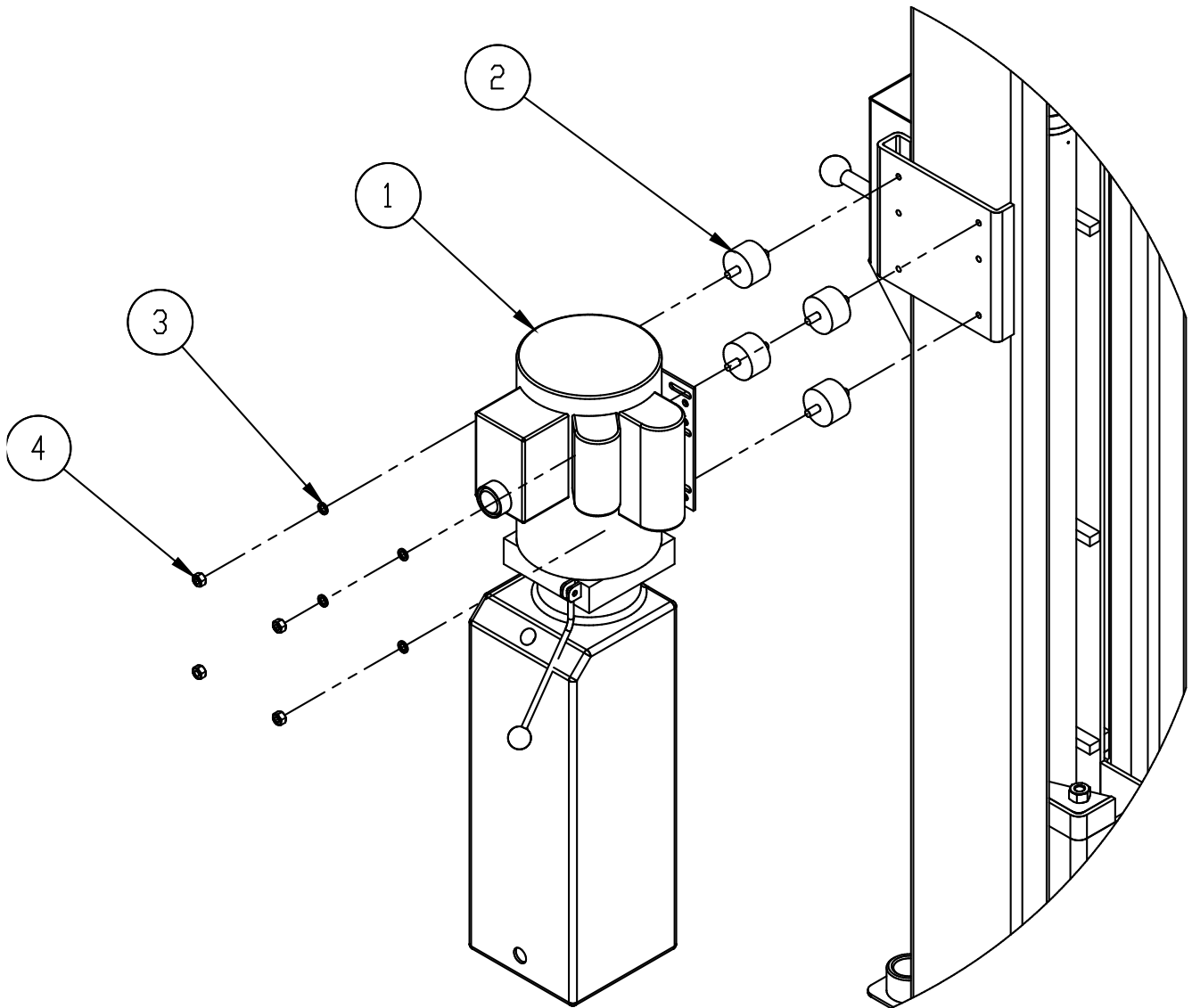

Item	Part Number	Description	Qty
1	32100002	Power Unit	1
2	12100541	Power Unit Mounting Rubber	4
3	32100522	8MM Lock Washer	4
4	32100524	M8 Nut	4

Diagram #12: SAFETY LOCK COVER & EXTENSION BRACKET

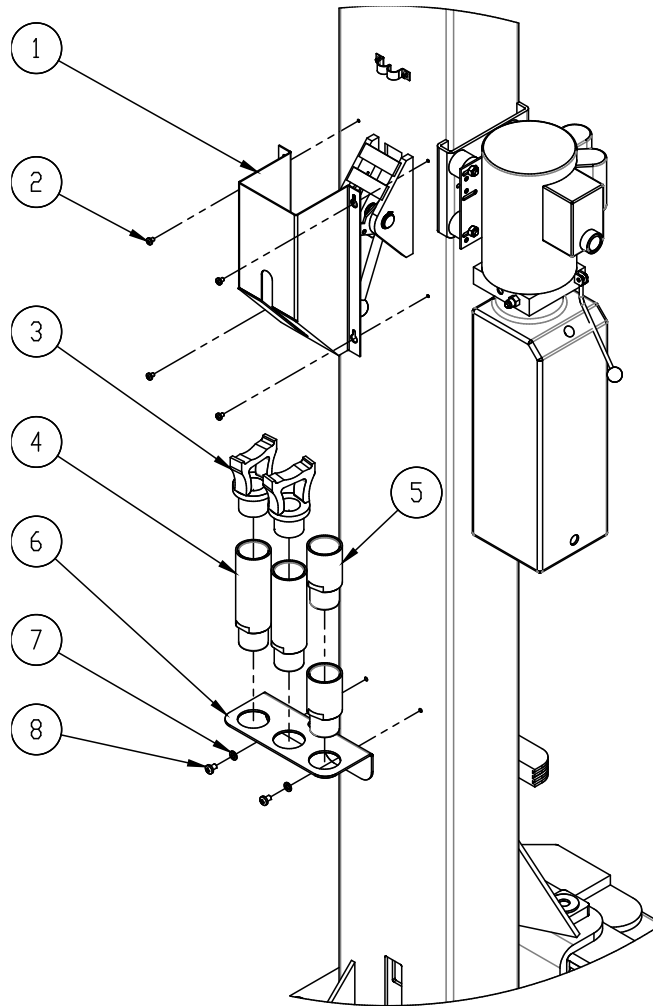

Item	Part Number	Description	Qty
1	12100547	Safety Cover – Power Side	1
	12100548	Safety Cover – Non Power Side	1
2	3C200023	Round Head Screw M6x8	8
3	22105008	Truck Adapter	4
4	12105101	6" (152mm) Extension	4
5	12105102	3" (76mm) Extension	4
6	12105110	Extension Bracket	2
7	3C200009	8MM Washer	4
8	3C200032	M8 Round Head Screw	4

Diagram #13: SAFETY INSTRUCTION and INFORMATION DECAL KIT LOCATION

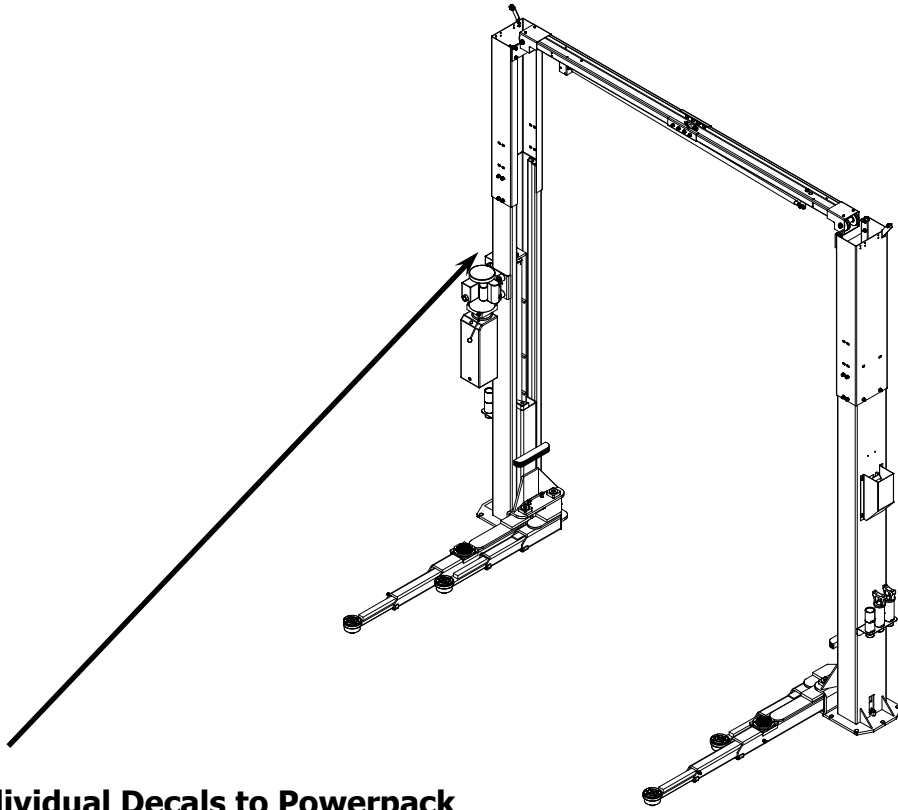

Individual Decals to Powerpack Column in clear view of operator

⚠ CAUTION	⚠ CAUTION	⚠ WARNING	⚠ WARNING
Lift to be used by trained operator only.	Authorized personnel only in lift area.	Clear area if vehicle is in danger of falling.	Position vehicle with center of gravity midway between adapters.
⚠ CAUTION	⚠ CAUTION	⚠ WARNING	⚠ WARNING
Use vehicle manufacturer's lift points.	Always use safety stands when removing or installing heavy components.	Remain clear of lift when raising or lowering vehicle.	Avoid excessive rocking of vehicle while on lift.
⚠ CAUTION	⚠ CAUTION	⚠ WARNING	⚠ WARNING
Use height extenders when necessary to ensure good contact.	Auxiliary adapters may reduce load capacity.	Do not override self-closing lift controls.	Keep feet clear of lift while lowering.
<small>The messages and pictographs shown are generic in nature and are meant to generally represent hazards common to all automotive lifts regardless of specific style. Funding for the development and validation of these labels was provided by the Automotive Lift Institute, PO Box 85 Cortland, NY 13045. Replacement label sets may be obtained from the original lift manufacturer and ALI's member companies. They are protected by copyright. www.autolift.org ©1992 by ALI, Inc. ALI/WL101c</small>		<small>The messages and pictographs shown are generic in nature and are meant to generally represent hazards common to all automotive lifts regardless of specific style. Funding for the development and validation of these labels was provided by the Automotive Lift Institute, PO Box 85 Cortland, NY 13045. Replacement label sets may be obtained from the original lift manufacturer and ALI's member companies. They are protected by copyright. www.autolift.org ©1992 by ALI, Inc. ALI/WL101c</small>	

Powerpack Column in clear view of operator

SAFETY INSTRUCTIONS	SAFETY INSTRUCTIONS
Read operating and safety manuals before using lift.	Proper maintenance and inspection is necessary for safe operation.
SAFETY INSTRUCTIONS	<small>The messages and pictographs shown are generic in nature and are meant to generally represent hazards common to all automotive lifts regardless of specific style. Funding for the development and validation of these labels was provided by the Automotive Lift Institute, PO Box 85 Cortland, NY 13045. Replacement label sets may be obtained from the original lift manufacturer and ALI's member companies. They are protected by copyright. www.autolift.org © 1992 by ALI, Inc. ALI/WL101s</small>
Do not operate a damaged lift.	

Diagram #14: WIRING DIAGRAM (1PH MOTOR)

