

COATS®

14,000 lb. (6,364 kg)

Scissor Lifts

Double Wall Runways with "Z" Rails, Built-in
Radius Plate Pockets & Rear Slip Plate

4TS140SAR1 (Alignment)

4TS140SOR1 (Service)



Installation Manual Operation Manual Service Parts Manual

READ the manual thoroughly before installing, operating, servicing, or maintaining the lift. SAVE this MANUAL and ALL INSTRUCTIONS.

HENNESSY
INDUSTRIES

1601 J.P. Hennessy Drive, LaVergne, TN 37086 (800) 688-6496 or (615) 641-7533

Hennessy Canada: 2430 Lucknow Drive, Unit 9, Mississauga, Ontario L5S 1V3 (905) 672-9440 www.coatsgarage.com

HENNESSY INDUSTRIES INC. Manufacturer of AMMCO®, COATS® and BADA® Automotive Service Equipment and Tools.

Manual Part No.: 85611157 00

Revision: 6/17

Your new lift will provide years of dependable service if installed, operated and maintained properly. **Read and be prepared to follow all safety, installation, operation, and maintenance instructions in this manual before installing and operating the lift. In addition, read and follow all safety and other information included on and with the lift before operating the lift. Keep this manual in a secure place for future reference, training and service part identification.**

TABLE of CONTENTS

1. Unloading Procedure and Lift Package Contents	page 3
2. Warranty and Safety	page 5
3. General Requirements and Lift Specifications	page 9
4. Pre Installation Procedures and Tools Required	page 10
5. Installation Procedures	page 13
6. Operating Instructions and Lift Maintenance	page 18
7. Troubleshooting	page 22
8. Lift Installation Diagrams and Parts Lists	page 25

IMPORTANT : It is the shop owner's responsibility to provide a satisfactory installation area for the lift. Lift should only be installed on level concrete floors with a minimum of 4 inches (102mm) and 3000 psi (20.7MPa) concrete that has been aged a minimum of 30 days. Please consult a qualified individual if any doubt exists concerning proper installation and subsequent safe operation of the lift. Do not install the lift on asphalt or outdoors.

Prior to installation, it is the shop owner's responsibility to provide constant electrical power in the correct voltage, phase, etc., and all wiring for electrical hook-up of the lift. The shop owner must insure that the electrical installation conforms to local building and safety codes. Where required, the shop owner will provide an electrical isolation switch located in close proximity to the lift. This switch will have an emergency stop capability and isolate electrical power from the lift for servicing requirements.

Hydraulic oil cannot be shipped with the lift and will be supplied by either the shop owner or the installer. ISO 32 hydraulic oil (10W non detergent hydraulic oil) must be used to fill the reservoir tank before operating the lift. Grout for lift leveling must also be purchased locally.

It is the shop owner's responsibility to train all operators in lift operation and lift safety.

UNLOADING PROCEDURE and LIFT PACKAGE CONTENTS

For your information:

All lift components are packaged together in one module held together by steel bands

UNPACKING PROCEDURE:

When the lift arrives on site:

- If possible have lift unloaded in the installation area
- Check for freight damage and report immediately to the trucking company who delivered the lift
- Check for missing parts and report immediately to the factory
1 - 877 - 799 - LIFT (5438) or (905) 847 - 1198

Main Components include:

Runway Assembly - labeled #1
Runway Assembly - labeled #2
Approach Ramps – 2pc
Accessory and Hardware Box (see list below)

Optional Accessories: (included only if ordered)

Rolling Air/Hydraulic Jacks - 1 jack per box c/w coiled air line
Turnplates - 1 turnplate per box c/w retainer brackets

Accessory Box includes:

Operator Console (power unit) – 1 pc
Hydraulic Hose for Return Oil Line – 1 pc
Air Hose for Safety Locks and Optional Rolling Jacks – 2 pc
Approach Ramp Bracket and Pin – 2 pc
Front Wheel Stops – 2 pc
Hydraulic Line Covers - 4 pc
Wheel Chocks – 2pc
WL 200 Series Safety Information Label Kit
ALI - "Lifting It Right "Manual
ALI - "Vehicle Manufacturer's Lifting Point Guide"
Automotive Lift Safety Tips Hang Card
Automotive Lift, Operation, Inspection and Maintenance Manual
Owner's Manual

Hardware Box includes: fittings, bolts, washers, nuts, anchor bolts, etc.



Important Notice

Krown Rust Proofing has been applied to specific areas of your new lift to ensure protection from corrosion.

- Please do not be alarmed if fluid is noticed dripping from openings of the Drive on Runways. This is normal.
- The application of the Krown Rust Proofing is completed in the final stage of the lift assembly process. To ensure protection and coverage, a generous amount is sprayed and may still be in a more fluid phase of its setup when your new lift is put into service. This will diminish over time, while maintaining protection of areas that are unable to be otherwise protected with paint coating.

WARRANTY AND SAFETY

Warranty: The scissor lift model identified in this manual has the following warranty from date of purchase:

Structural Components - 5 years

Hydraulic and Other Components - 1 year

Accessory Items - 90 days

Labor - 1 year

The above items are warranted to be free of defects in material and workmanship to the original owner of the lift as follows: During the first year (90 days for accessories), those parts proven after inspection to be defective shall be repaired or replaced at the option of the manufacturer. Structural components only are warranted for an extended four years and if proven after inspection to be defective shall be repaired or replaced at the option of the manufacturer. This warranty does not extend to defects caused by ordinary wear, misuse, abuse, improper maintenance, shipping damage or where repairs have been attempted or made by anyone other than the manufacturer or a manufacturer certified technician. This warranty is exclusive and in lieu of all other warranties express or implied. In no event shall the manufacturer be liable for special, incidental or consequential damages for any breach or delay in performance of the warranty. The manufacturer reserves the right to change specifications, designs or add improvements to its product line without incurring any obligation to make such changes to products sold previously.

IMPORTANT SAFETY INSTRUCTIONS

When using your garage equipment, basic safety precautions should always be followed, including the following:

1. Read all instructions
2. Care must be taken as burns can result from touching hot parts
3. Do not operate equipment with a damaged cord or if equipment has been dropped or damaged – until it has been examined by a qualified service person
4. Do not let a cord hang over the edge of the table, bench, or counter or come in contact with hot manifolds or moving fan blades
5. Let equipment cool completely before putting away. Loop cord loosely around equipment when storing
6. To reduce risk of fire, do not operate equipment in the vicinity of open containers of flammable liquids (gasoline)
7. Adequate ventilation should be provided when working on operating internal combustion engines
8. Keep hair, loose clothing, fingers, and all parts of body away from moving parts
9. To reduce the risk of electric shock, do not use on wet surfaces or expose to rain
10. Use only as directed in this manual. Use only manufacturer's recommended attachments
11. ALWAYS WEAR SAFETY GLASSES. Everyday eyeglasses only have impact resistant lenses, they are not safety glasses

SAVE THESE INSTRUCTIONS

Basic common sense safety precautions should always be followed when installing, operating and maintaining the lift as a risk of fire, electric shock, or injury may be present.

In addition:

1. Read and follow all safety instructions and decals included with the lift. Read and follow all safety instructions in this manual. Read and follow the ALI "Lifting It Right" manual (included with the lift). Always use the "Vehicle Lifting Points" reference guide when lifting a vehicle. Insure all materials stay up to date >>> www.autolift.org/
2. Only trained and authorized personnel should position a vehicle and operate the lift. Do not allow customers or bystanders to operate the lift or be in the lift area.
3. Inspect the lift daily. Do not operate if potential problems have been identified or lift malfunctions. Do not operate if lift has damaged or broken components. Never walk or work under the lift unless all safety locks are completely engaged.
4. Never overload the lift. The rated capacity decal is located on the operator console. The hydraulic system on this lift is not designed to be a load holding device. Mechanical safety locks must be engaged before proceeding under the lift for vehicle servicing or lift maintenance. Never override operating controls. This is unsafe and will void the warranty.
5. Before driving a vehicle onto the lift, insure that both slip plates and turn plates have all lock mechanisms securely in position. Also insure that the lift and lift area is clear of all debris and that all oil and grease has been cleaned from runway surfaces.
6. Before raising or lowering the lift, always totally secure the vehicle with wheel chocks.
7. When using a jack(s) to raise a vehicle, position jack lifting pads to contact vehicle manufacturer's recommended lifting points. Raise jack slowly until all pads contact the vehicle. Confirm that the vehicle is stable on the jack(s) before raising to desired working height.
8. Some pickup trucks may require optional truck adapters to clear running boards and other installed accessories. Special care must be exercised with pick-up trucks to insure safe lifting. Always use vehicle manufacturers lifting points and insure the contents of the cargo box will not affect vehicle balance while on the jack(s).
9. Important: Removal or installation of heavier parts can change the vehicle's center of gravity on the jack(s) resulting in a critical load shift. The vehicle may then be unstable. Plan ahead for this possibility to insure continued safety and refer to the vehicle manufacturer's service manual for recommended procedures.
10. Always keep the lift area free of obstructions and debris. Grease and oil spills should be cleaned up immediately.
11. Never raise a vehicle on the lift with passengers inside. Before lowering, check the lift and lift area and remove all obstructions. Before removing vehicle from the lift or lift area, confirm an unobstructed exit.

Owner/Employer Responsibilities

The owner/employer:

Shall ensure that lift operators are qualified and that they are trained in the safe use and operation of the lift using the manufacturer's operating instructions; ALI/SM, "Lifting It Right" safety manual; ALI/ST, "Safety Tips" card; ANSI/ALI ALOIM, Standard for Automotive Lifts – Safety Requirements for Operation, Inspection and Maintenance; ALI/WL Series, ALI Uniform Warning Label Decals/Placards; and in the case of frame engaging lifts, ALI/LP-Guide, "Quick Reference Guide – Vehicle Lifting Points for Frame Engaging Lifts".

Shall establish procedures to periodically inspect the lift in accordance with the lift manufacturer's instructions or ANSI/ALI ALOIM, Standard for Automotive Lifts – Safety Requirements for Operation, Inspection and Maintenance; and the employer shall ensure that lift inspectors are qualified and that they are adequately trained in the inspection of the lift.

Shall establish procedures to periodically maintain the lift in accordance with the lift manufacturer's instructions or ANSI/ALI ALOIM, Standard for Automotive Lifts – Safety Requirements for Operation, Inspection and Maintenance; and the employer shall ensure that lift maintenance personnel are qualified and that they are adequately trained in the maintenance of the lift.

Shall maintain the periodic inspection and maintenance records recommended by the manufacturer or ANSI/ALI ALOIM, Standard for Automotive Lifts – Safety Requirements for Operation, Inspection and Maintenance.

Shall display the lift manufacturer's operating instructions; ALI/SM, "Lifting It Right" safety manual; ALI/ST, "Safety Tips" card; ANSI/ALI ALOIM, Standard for Automotive Lifts – Safety Requirements for Operation, Inspection and Maintenance; ALI/WL Series, ALI Uniform Warning Label Decals/Placards; and in the case of frame engaging lifts, ALI/LP-Guide, "Quick Reference Guide – Vehicle Lifting Points for Frame Engaging Lifts"; in a conspicuous location in the lift area convenient to the operator.

Shall review and understand the proper requirements outlined in ANSI/ALI ALIS, Safety Requirements for Installation and Service of Automotive Lifts.

Shall consult with a qualified person to address seismic loads and other local or state requirements.

Safety Instruction and Information Decal Kit (included with the lift)

Automotive Lift Institute, Inc.

WL200 Series Label Kit

ELECTRICAL SAFETY DECAL

CAUTION	CAUTION
Lift to be used by trained operator ONLY.	Authorized personnel only in lift area.

WARNING	WARNING
Clear area if vehicle is in danger of falling.	Remain clear of lift when raising or lowering vehicle.

The messages and pictographs shown are generic in nature and are meant to generally represent hazards common to all automotive lifts regardless of specific style.
Funding for the development and validation of these labels was provided by the Automotive Lift Institute, PO Box 85 Cortland, NY 13045.
Replacement label sets may be obtained from the original lift manufacturer and ALI's member companies. They are protected by copyright.
www.autolift.org ©1992 by ALL Inc. ALI/WL200s

<p>ATTENTION: MOTEUR NON PROTÉGÉ—PROTECTION EXTERIEURE CONTRE LA SURCHAUFFE DOIT ÊTRE ASSURÉE CONFORMÉMENT AU CODE CE, PREMIÈRE PARTIE</p> <p>COURANT ADMISSIBLE MINIMAL DE LA DÉRIVATION: 25A.</p> <p>COURANT NOMINAL MAXIMAL DU FUSIBLE DE LA DÉRIVATION: 30 A.</p> <p>AVERTISSEMENT: IL EST DANGEREUX DE TROP ARROSER LE MATÉRIEL ET LES CÂBLES ÉLECTRIQUES</p> <p>SI CONNECTÉ À UN CIRCUIT PROTÉGÉ PAR DES FUSIBLES UTILISER DES FUSIBLES À UNE ACTION DIFFÉRÉE MARQUÉS "D"</p> <p>NE PAS UTILISER À UN NIV EAU INFÉRIEUR À CELUI DU PLANCHER DU GARAGE OU DU SOL.</p> <p>CAUTION: RISK OF ELECTRIC SHOCK - DO NOT REMOVE COVER - NO USER SERVICEABLE PARTS INSIDE - REFER SERVICING TO QUALIFIED SERVICE PERSONNEL</p> <p>SAFETY INSTRUCTIONS: IF ATTACHEMENTS, ACCESSORIES OR CONFIGURATION MODIFYING COMPONENTS THAT ARE LOCATED IN THE LOAD PATH, AFFECT OPERATION OF THE LIFT, AFFECT THE LIFT ELECTRICAL LISTING OR AFFECT INTENDED VEHICLE ACCOMMODATION ARE USED ON THIS LIFT AND, IF THEY ARE NOT CERTIFIED FOR USE ON THIS LIFT, THEN THE CERTIFICATION OF THIS LIFT SHALL BECOME NULL AND VOID. CONTACT THE PARTICIPANT FOR INFORMATION PERTAINING TO CERTIFIED ATTACHEMENTS, ACCESSORIES OR CONFIGURATION MODIFYING COMPONENTS.</p>	<p>CAUTION: MOTOR NOT PROTECTED— EXTERNAL OVERHEAT PROTECTION IN ACCORDANCE WITH CE CODE, PART 1, MUST BE PROVIDED</p> <p>MINIMUM CIRCUIT AMPACITY OF CONDUCTOR IS 25 A.</p> <p>MAXIMUM BRANCH CIRCUIT FUSE IS 30 A.</p> <p>WARNING: IT IS DANGEROUS TO OVERSPRAY THE ELECTRICAL APPARATUS AND WIRING</p> <p>IF CONNECTED TO A CIRCUIT PROTECTED BY FUSES USE TIME DELAY FUSE MARKED "D"</p> <p>DO NOT USE BELOW GARAGE FLOOR OR GRADE LEVEL</p>
---	--

This piece of garage equipment is specified by the manufacturer for Intermittent Operation with a maximum "on" time of 75 seconds and a corresponding "off" time of 525 seconds for the equipment.

51140100

SAFETY INSTRUCTIONS	SAFETY INSTRUCTIONS
Read operating and safety manuals before using lift.	Proper maintenance and inspection is necessary for safe operation.

WARNING	WARNING
Keep clear of pinch points when lift is moving.	Keep feet clear of lift while lowering.

SAFETY INSTRUCTIONS	SAFETY INSTRUCTIONS
Do not operate a damaged lift.	Check wheel to prevent vehicle movement.

WARNING	WARNING
Do not override self-closing lift controls.	Check wheel to prevent vehicle movement.

The messages and pictographs shown are generic in nature and are meant to generally represent hazards common to all automotive lifts regardless of specific style.
Funding for the development and validation of these labels was provided by the Automotive Lift Institute, PO Box 85 Cortland, NY 13045.
Replacement label sets may be obtained from the original lift manufacturer and ALI's member companies. They are protected by copyright.
www.autolift.org ©1992 by ALL Inc. ALI/WL200s

IMPORTANT :

Insure Safety Instruction Decals and Hang Card are affixed to the lift console or operator pendant immediately following installation and before the lift is used

Review all safety information daily with all lift operators

**LIFT SAFETY and LIFT MAINTENANCE
MUST BE PART OF YOUR DAILY ROUTINE**

GENERAL REQUIREMENTS and LIFT SPECIFICATIONS

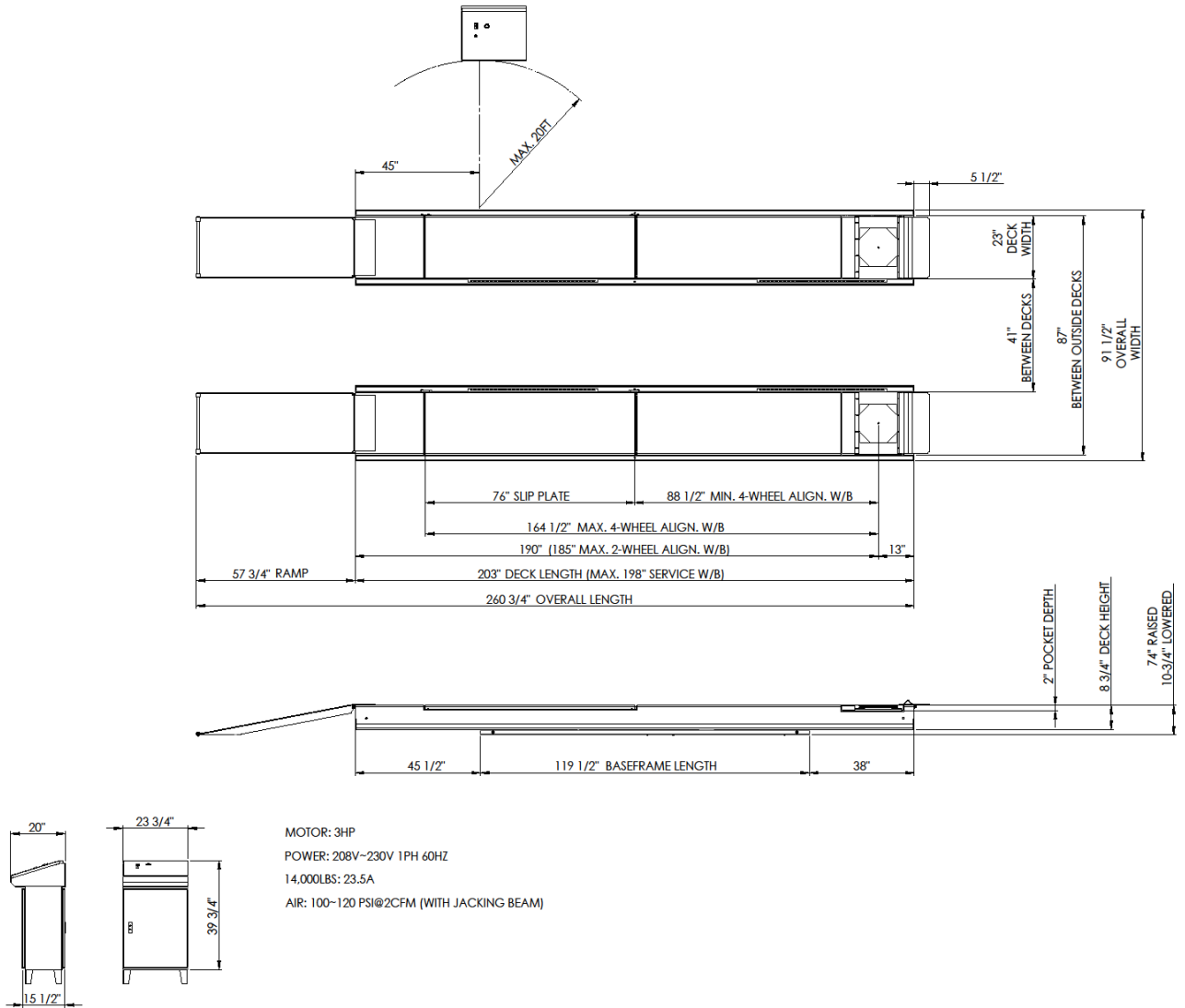

14,000 lb. (6,350 kg) Capacity - 7,000 lbs. (3,175 kg) each Runway

Lift should only be installed on level concrete floors with a minimum of 4 inches and 3000 psi (20.7MPa) concrete that has been aged a minimum of 30 days. A qualified person should be consulted to address seismic loads and other local or state requirements.

A constant supply of 230 volt – 1 phase – 60 Hz – 30 amp electrical power and a constant supply of 125 psi dry compressed air is required for this lift.

This lift is designed for INDOOR use only, outdoor installation is prohibited.

Ongoing design modifications and quality improvements may change specifications listed in this manual without notice

BAY DIMENSIONS

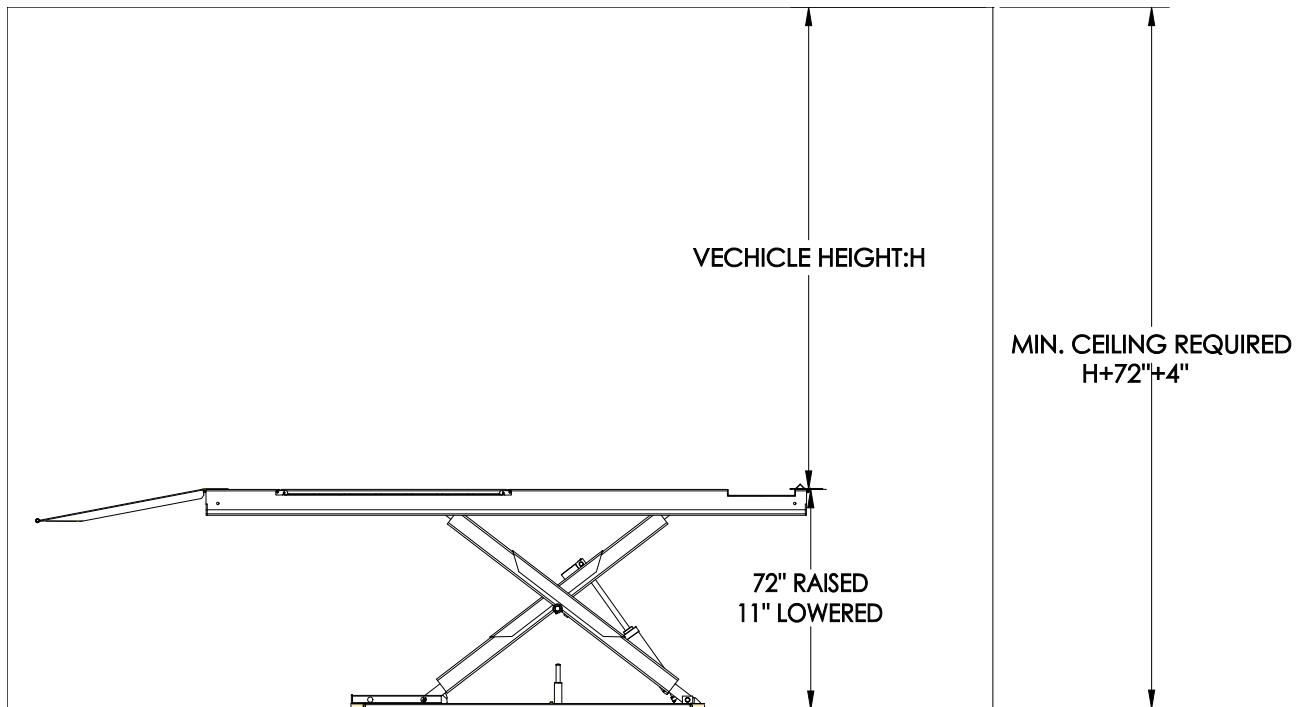
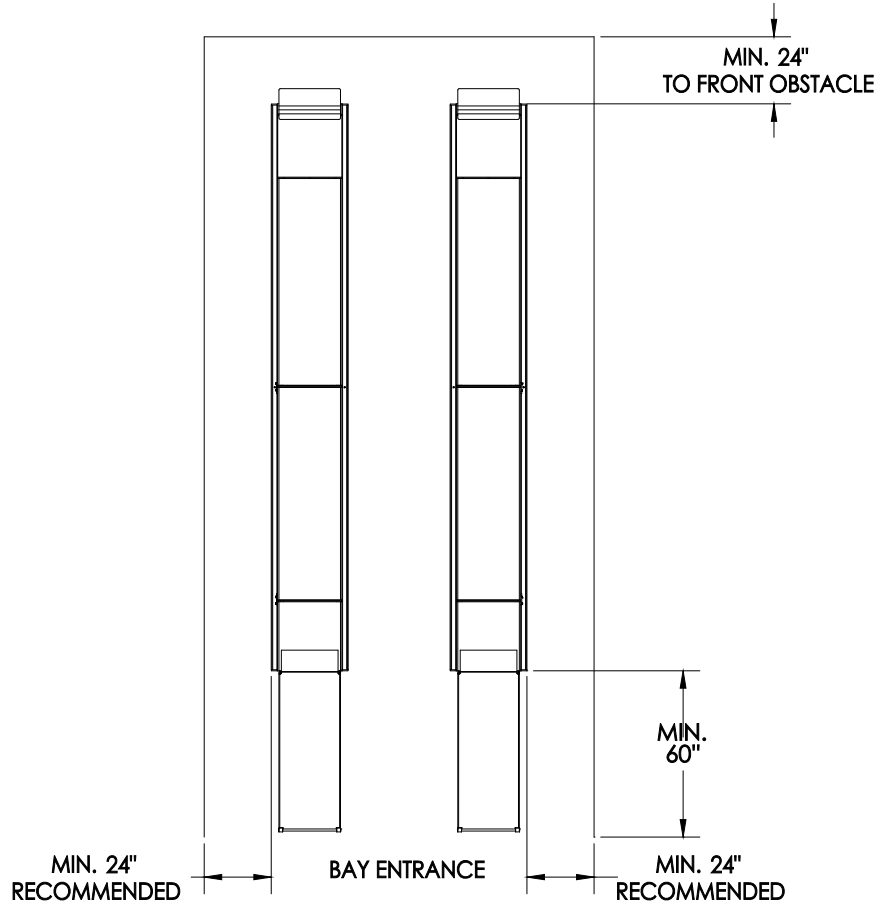

TOOLS REQUIRED and PRE INSTALLATION PROCEDURES

Tools Required:

- ✓ 25ft. Measuring Tape
- ✓ Chalk Line and Chalk
- ✓ Side Cutters (tin snips)
- ✓ Floor Jacks – 2 (or engine crane)
- ✓ Crow Bar
- ✓ Metric and SAE Wrenches and Ratchet Sets
- ✓ Metric and SAE Allen Key Sets
- ✓ Hammer
- ✓ Screwdrivers
- ✓ 4 ft. Level (and laser level)
- ✓ Rotary Hammer Drill
- ✓ 5/32 inch and 5/8 inch diameter Masonry Drill Bits
- ✓ Grout – 1 pail purchased locally (see last page of this manual for reference information)
- ✓ Trowel, Float and Mixing Pail for hydraulic grout

Pre Installation Procedures

Before proceeding with installation, read the installation manual and insure all instructions are fully understood and all component parts are accounted for.

IMPORTANT: DO NOT CUT THE SHIPPING STRAPS HOLDING EACH RUNWAY ASSEMBLY TOGETHER UNTIL INSTRUCTED TO DO SO (step 3 – page 9).

1. Identify bay center line near the front and mark the floor. Also mark the center of bay entrance door. Connect these two points with a chalk line. Locate the position for front of the lift and draw a second chalk line at 90° to the centerline (this will be used to position the fronts of both runway assemblies - refer to lift dimensions on page 7).
2. At the front, measure 20 inches out from either side of the centerline and mark the floor. Near where the rear of the lift will be, measure 20 inches out from either side of the centerline and mark the floor. Using these marks draw two parallel chalk lines the length of the lift (these will be used to position the inside edge of each base frame).

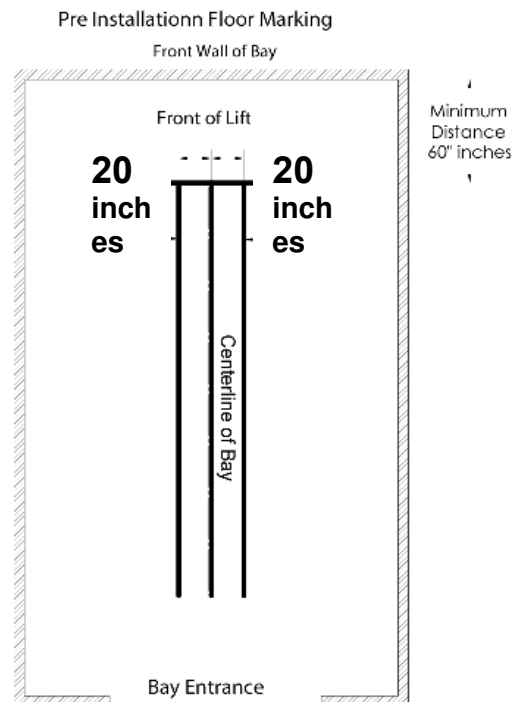

3. Carefully remove accessory box, (rolling air/hydraulic jack(s), and turnplate boxes if applicable) from on top of runway assemblies. Identify top runway assembly (see diagram to the right > >). Move it to its proper position on the chalk lines you have marked. Use extreme care not to damage preinstalled hydraulic, air and electrical lines stored under the rear of each runway assembly. Remove approach ramps from lower runway assembly and set off to one side. Position second runway assembly on the chalk lines you have marked. Confirm that turnplate pockets are at the front of the bay and that all base frame edges are a minimum 6 inches from any floor seam. All anchor bolts must also be a minimum of 6 inches away from any floor seam. Do not install if floor has cracks or deterioration that could affect lift stability or safety. The shop owner is responsible for confirming there are no obstructions in the installation area like floor drains, under floor piping or electrical conduit that could be damaged or would prevent safe lift installation and secure lift anchoring. Check ceiling for beams or heating ducts and walls for protruding structures, etc.. Insure that the lift can be safely installed in the position you have marked on the bay floor. Remove all packaging material from installation area.

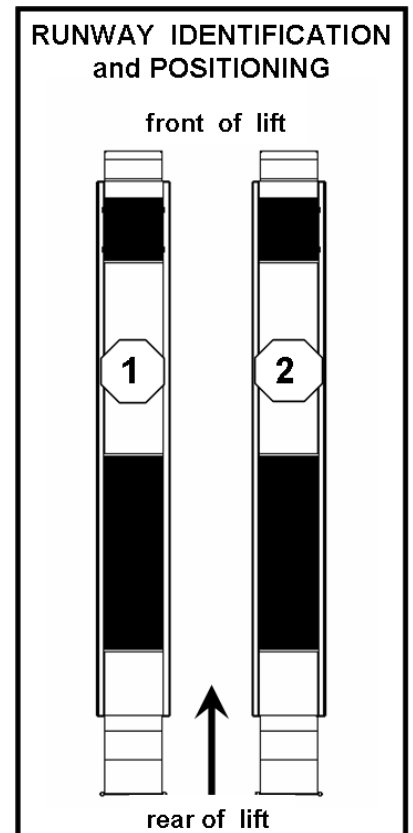

INSTALLATION PROCEDURE

See the Installation and Parts Reference section of this manual for diagrams and parts lists that will assist you during the installation process (pages 14 – 28). Use these diagrams and parts lists together with the following written instructions. Insure the lift installation complies with ANSI/ALI/ALIS, Safety Requirements for Installation and Service of Automotive Lifts.

1. Remove hydraulic, air and electrical lines from under the rear of each runway assembly. Use extreme care not to damage any of these preinstalled items. Place on top of runway.
2. Unbolt steel shipping supports and remove from installation area.
3. Confirm that the front of both runways and inside base frame edges are on the chalk lines you have marked. Also confirm that the runway assemblies are parallel to one another (inside base frame distance front and rear must be equal - diagonal base frame distances front to rear must also be equal). After confirming that the two runway assemblies are exactly where they need to be, remove the shipping straps.
4. Unpack operator console and move to desired location (reference diagram #1).
5. Carefully uncoil hydraulic, air and electrical lines and route them to the operator console insuring there are no kinks.
6. Connect hydraulic, air and electrical lines as follows: (reference diagrams #3 to #8).
 - a. Connect hydraulic line from passenger side of lift to console manifold marked "passenger side". Connect hydraulic line from driver side of lift to console manifold marked "driver side".
 - b. Connect passenger side return oil line (5/32" black tubing) to "T" fitting from accessory box. Connect driver side return oil line (5/32" black tubing) to "T" fitting. Connect "T" fitting to oil reservoir cap in console using 5/32" black tubing from accessory box.
 - c. Connect passenger side safety lock air line (5/32" blue tubing) to "T" fitting from accessory box. Connect driver side safety lock air line (5/32" blue tubing) to "T" fitting. Connect "T" fitting to air solenoid in console using 5/32" blue tubing from accessory box.
 - d. Connect rolling air/hydraulic jacks air line from lift to console (if optional rolling jacks were purchased) **(rolling jacks must be installed with air lines connected to the lift before turning on the air).**

e. **Electrical Power Hook Up**

WARNING: All electrical wiring other than low voltage (24 volts or less) should be performed by a certified electrician.

Connect Electrical Cable Direct to Contactor's L1 & L3 Terminal (VAC230~208 1PH). Ensure a proper ground connection.

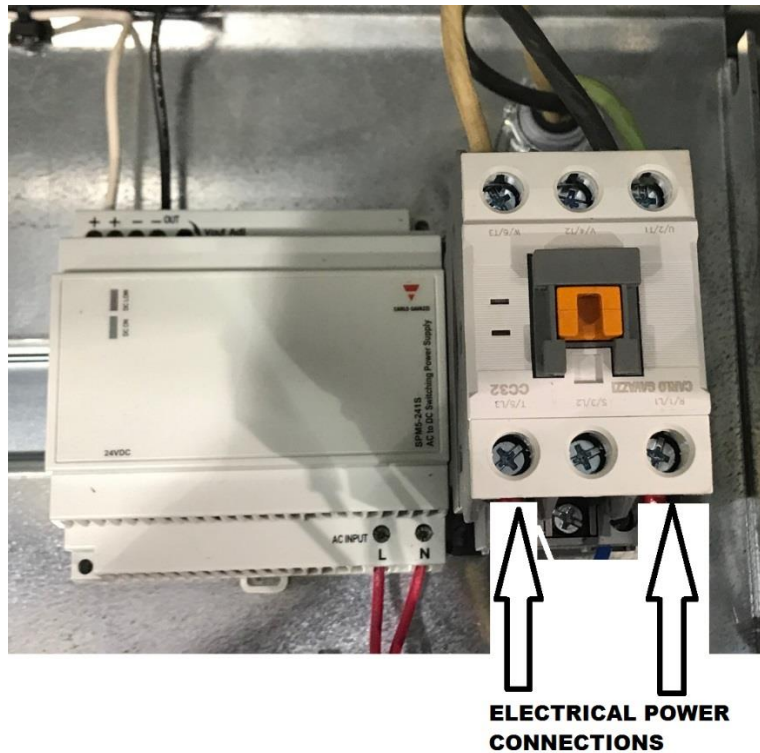

WARNING: DO NOT CONNECT ANY HIGH VOLTAGE ELECTRICAL WIRE TO PCB BOARD.

- f. **Low Voltage Linear Transducer (potentiometer) Connections** – Follow Diagram #7 (pg. 31) to make the connections. The two white wire must match the location on the diagram.(driver side and passenger side).



7. Fill oil reservoir with hydraulic oil (ISO 32).
8. Connect operator console or control pendant to electrical service. **(should be performed by a certified electrician).**
9. Lift operation controls on the console perform the following functions:

"RAISE" button raises the lift. "LOWER" button lowers the lift. Note: Pressing the "lower" button will first raise the lift slightly to clear the safety locks and then proceed down to desired height.

"ALIGNMENT LEVEL" button lowers the lift into safety locks for alignment purposes. Note: The "alignment level" button and the "lower" button must be pressed at the same time to lower and level the lift on the safety locks.

"EMERGENCY STOP" button stops the lift from being raised or lowered.

Note: Always lock both slip plates and turnplates following alignment adjustments and before removing vehicle from the lift.
10. Press the "UP" button and raise the lift 18 inches from the floor. Press the "DOWN" button and lower the lift down to the floor. Check hydraulic oil level in operator console reservoir and top up if required. Check all hydraulic and air lines to insure no leaks.
11. Press the "UP" button and raise the lift 36 inches from the floor. Press the "DOWN" button and lower the lift down to the floor. Press the "UP" button and raise the lift 60 inches from the floor. Insure the safety locks under both runway assemblies are engaging properly when the lift is being raised.

12. Levelling Procedure

Important: Before proceeding, confirm that all safety locks are totally engaged. This can be done by holding the green button (alignment button) and then pressing lowering button.

Dependable performance and accurate alignment results require a precisely leveled lift. Take special care to complete the following leveling process: Check both base frames with a 4 ft. level and identify the highest point.

The leveling process will raise lower points on both decks to match (or be level with) the high point you identify. Using preinstalled adjustment bolts located at the front and rear of each base frame, proceed to raise the low points on each base frame to match (or be level with) the highest point you identified. (reference diagram #9 for correct level measurement sequence).

Note: adjustment bolts cannot be used to support the lift when in use. They are only used during the leveling process. Proper shims or grout must be used to support the load.

Grout thickness (measured from the floor to the bottom edge of a base frame) cannot exceed 1½ inches. Confirm this maximum limit is not exceeded by taking

measurements at one foot intervals around both decks. If you measure a distance greater than 1½ inches stop the installation and call the manufacturer at 1 - 866 - 799 - LIFT (5438). The manufacturer will advise you how to proceed (grout installation is step #14).

13. If both decks are completely level and base frames are located exactly on the chalk lines you have drawn, drill and install all 5/8" anchor bolts, washers and nuts. DO NOT TIGHTEN. Grout must be installed and allowed to completely cure before tightening anchor bolts. Wear safety goggles and practice caution when drilling anchor bolt holes.
14. A sufficient quantity of grout must be purchased locally. Refer to grouting instructions on the container. Evenly distribute grout under the total base frame area and finish edges with a 45 degree chamfer. Leave a small opening at the lowest point on the floor under both base frames for adequate drainage of any liquid. Refer to recommended cure times on the grout package. **Do not operate lift or disturb grout during curing process.**
15. While waiting for the grout to cure, fine tune the routing of hydraulic, return oil, air and electric lines from the lift to the console carefully placing them under line covers provided. Insure a kink free routing. Confirm that the operator console is exactly where you want it and that all lines are safely enclosed by the line covers. Drill and install anchor bolts for line covers. Coil excess hydraulic, air and electrical lines and secure with cable ties in lower area of the operator console.
16. Install both front wheel stops and rear approach ramp brackets (reference diagram #10).
17. Refer to manufacturer's recommended cure times and confirm that all grout has completely cured. Back off all leveling adjustment bolts two turns. Torque all anchor bolts to 75 ft.-lbs. (102Nm). *Anchor bolt security is a monthly maintenance check.*
18. Runways should be level (front to back and side to side) in the down position. Using the leveling support bolts located in each corner of both base frames, level both runways (reference diagram #9). This may involve raising and lowering the lift several times.
19. Raise the lift to about 3ft high, let both decks sit on locks by pressing "alignment" and "down" button on console or pendant. Check levelling and then press and hold "reset" button on control board in the console for 2 second. Press and hold "zero" button on control board for 2 seconds. The lift now should be levelled mechanically and electronically.
20. Install rear approach ramps using pins, washers and cotter pins.
21. Install rolling air/hydraulic jacks (if applicable) and connect air lines.
22. To avoid damage, safety instruction and information decals are not applied at the factory but shipped with the lift. The ALI - WL200 Series Label Kit or WL2200 hang card must be applied to lift console or control pendant before the lift is used (reference

diagram #11). Insure that all lift operators are trained in all points covered by this and other safety information.

Insure this manual along with all operation, inspection and maintenance instructions are delivered to the owner/user/employer

Final Checkout Procedure of Assembled Lift

- ✓ Confirm that all hydraulic and air lines are tight with no leaks
- ✓ Check hydraulic oil level in reservoir and confirm hydraulic system has been bled of all air
- ✓ Confirm that all electrical components have been wired properly and are operational
- ✓ Confirm lift base and runways are level and all anchor bolts torque to 75 ft.-lbs. (102Nm)
- ✓ Confirm safety locks are functioning properly
- ✓ Lubricate all lubrication points

OPERATING and MAINTENANCE INSTRUCTIONS

LIFT OPERATION: Before lifting a vehicle, insure all operators are qualified, have been trained and are following all safety instructions. Read and follow the ALI "Lifting It Right" manual included with the lift. (see example of SAE J2184 standard below)

Insure that every vehicle will be securely positioned on the lift (use wheel chocks). When using air/hydraulic rolling jacks to lift a vehicle, always use vehicle manufacturer's recommended lifting points (CD included with the lift). Insure all materials stay up to date >>>

www.autolift.org/

Never allow anyone under the lift when raising or lowering. Always insure mechanical safety locks are completely engaged on both sides of the lift before proceeding under the lift or a vehicle.

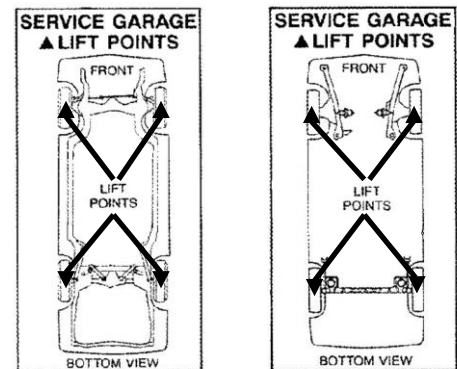

Typical Label Drawings
Reprinted with permission from SAE J2184
©2000 Society of Automotive Engineers, Inc.

Lift operating controls are located on the console or hand held pendant (one "up" button for raising the lift - one "level" button for lowering the lift into the safety locks for alignment - and one "down" button for lowering the lift). Note: When pressing the "down" button, the lift will first raise slightly to clear the safety locks and then proceed to lower.

LIFT OPERATIONAL TEST WITH A TYPICAL VEHICLE:

To Raise Vehicle:

1. Lower runways to the floor position.
2. Ensure ramps are well engaged .
3. Clear all debris from the path of the vehicle.
4. During loading or spotting, center the vehicle between the runways as shown in figure above.
5. Drive the Vehicle onto the lift slowly, engage both the safety brake, and chock the wheels.
6. Clear area around the lift.
7. Raise the vehicle to the desired working elevation and release control button.
9. Lower the runways until they completely contact the mechanical safety locks. The vehicle is now ready for service.

To Lower Vehicle:

1. Clear area around and under the lift of obstructions and warn personnel to stand clear.
2. Push the Lowering Button
6. Lower the lift until runways have bottomed and all movement has stopped.
7. Remove the wheel Chocks, and start the vehicle, disengaging the Safety Brake.
8. Remove the vehicle.

LIFT MAINTENANCE : Before maintaining, servicing or repairing the lift, insure that an acceptable "lock out/tag out device is activated.

The following minimum maintenance schedule must be performed by the owner and/or lift operator:

- DAILY:**
- Raise and lower the lift (with no vehicle) at the beginning of each shift to verify the runways are level and that the lift is operating properly.
 - Check all hydraulic fittings and lines for damage and leaks. Check electrical wiring for damage. Check all moving parts for uneven or excessive wear. Repair or replace all damaged, worn, or broken components immediately.
 - Clean all debris from the base frame area
 - Remove oil/grease on runways and rolling jack lift pads.

- WEEKLY:**
- Check hydraulic fluid in console reservoir and top up if required.
 - Check safety lock adjustment.

- MONTHLY:**
- Check that all anchor bolts are torqued to 75 ft-lbs (102Nm).
 - Clean and lubricate moving parts (see diagram #4 for grease fitting locations)

- EVERY YEAR:**
- Arrange for a Trained Lift Service Person to inspect and certify all aspects of the lift as per "Automotive Lift Operation, Inspection and Maintenance" (ALOIM) guidelines.

- EVERY TWO YEARS:**
- Change and replace hydraulic oil in cylinders and console reservoir.

- Lubrication Specifications:**
- where grease is required use a multi-purpose lithium grease
 - where lubricating oil is required use a SAE 30 oil
 - where hydraulic oil is required use ISO 32 – 10W non detergent hydraulic oil.

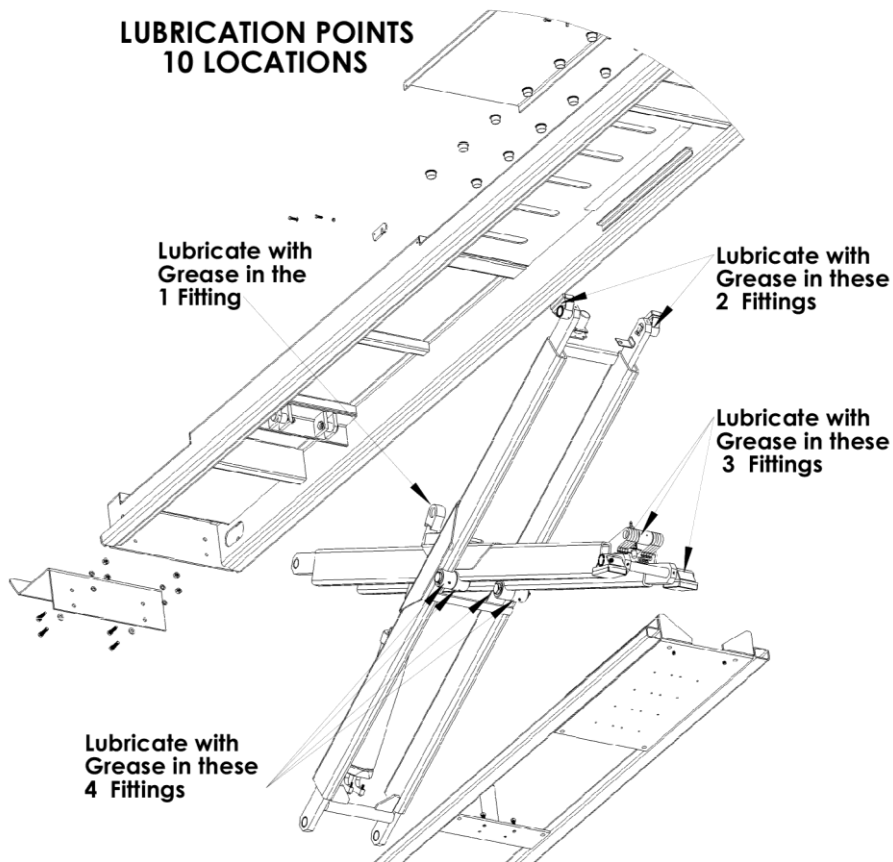

Replace all worn or broken parts and components only with manufacturer approved/supplied parts and components

Replacement parts may be purchased from your local lift supplier or the manufacturer at 1 - 877 - 799 - LIFT (5438) or (905) 847 - 1198

LIFT PROBLEM TROUBLESHOOTING GUIDE

The following are suggestions to consider if you have problems with the lift. Please call a Trained Lift Service Person and/or qualified electrician for further clarification and information.

Problem	Cause	Solution
Lift Will Not Raise or Lower	<ol style="list-style-type: none"> 1. Blown fuse or circuit breaker 2. "Emergency Stop" button engaged 3. Tripped thermal overload 4. Incorrect voltage to motor 5. Bad wiring connections 6. "UP" switch burned out 7. Motor windings burned out 8. Side to side synchronization has exceeded maximum limits 	<ol style="list-style-type: none"> 1. Replace fuse or reset/replace circuit breaker 2. Release button or replace 3. Reset thermal overload 4. Supply correct voltage to motor 5. Repair and insulate all connections 6. Replace switch 7. Replace motor 8. Call a Trained Lift Service Person for assistance
Lift Will Not Raise	<ol style="list-style-type: none"> 1. Air in oil or low oil level 2. Lowering Valve leaks 3. Motor runs backward 4. Pump damaged 5. Pump will not prime 6. Relief Valve leaks 7. Voltage to motor incorrect 8. Lift overloaded 	<ol style="list-style-type: none"> 1. Check fluid level, oil seal, bleed system 2. Clean valve or replace 3. Check for correct wiring 4. Repair or replace pump 5. Check fluid level and pick-up tube - replace pump 6. Clean Relief Valve (replace if necessary) 7. Supply correct voltage to motor 8. Verify that loaded vehicle weight does not exceed rated lift capacity
Lift Will Not Lower	<ol style="list-style-type: none"> 1. Faulty lowering solenoid valve 2. Obstruction under lift or in roller tracks 	<ol style="list-style-type: none"> 1. Replace valve 2. Carefully remove obstruction
Lift Will Not Hold Pressure	<ol style="list-style-type: none"> 1. Contamination in system 2. Internal Cylinder leaks 3. Lowering Valve leaks 4. Check Valve leaks 5. External leaks 	<ol style="list-style-type: none"> 1. Check oil level - bleed cylinders - remove contamination - replace oil seal 2. Check fitting, replace cylinder 3. Contaminated fluid, handle binds, clean valves 4. Clean check valve (replace if necessary) 5. Check all fittings and repair leaks
Lift Going Up Out of Level	<ol style="list-style-type: none"> 1. Lift installed on un-level floor 2. Linear Transducer Cables at the lift have changed position relative to one another 	<ol style="list-style-type: none"> 1. Reinstall on level surface 2. Adjust (rotate) one cable to match the position of the opposite cable. Call a Trained Lift Service Person if problem persists
Anchors Will Not Stay Tight	<ol style="list-style-type: none"> 1. Holes drilled oversize 2. Concrete floor thickness or holding strength not sufficient 	<ol style="list-style-type: none"> 1. Relocate lift using the correct bit to drill holes 2. Break out old concrete and re-pour new foundation per lift installation instruction
Locking Mechanisms Do Not Engage / Disengage	<ol style="list-style-type: none"> 1. Safeties are binding 2. Faulty air cylinder 3. Damaged air line 4. Safety locks do not latch properly 5. Safety locks do not disengage 	<ol style="list-style-type: none"> 1. Lubricate mechanism 2. Replace air cylinder 3. Repair/replace air line 4. Adjust mechanisms per lift installation instructions 5. Check air supply and air cylinder – replace if required. Reset electronic circuit by pressing "Emergency Stop Button" for 15 seconds and then release it. Call a Trained Lift Service Person

TLS Scissor Lift Re-levelling Procedure

Functions of buttons on the control board:

There are 7 (seven) press buttons on the control board.

Button	Function
Reset	To reset the board.
Zero	To make the current potentiometer voltage different values as new reference number or zero point. When the hoist is running, system will adjust the height on each runway to maintain this value.
Motor	To run the motor.
Pass	To open passenger side proportional valve.
Driver	To open driver side proportional valve.
Air	To lift safety locks by supplying air to the air cylinder.
Descent	To open the lowering valve, and two check valves.

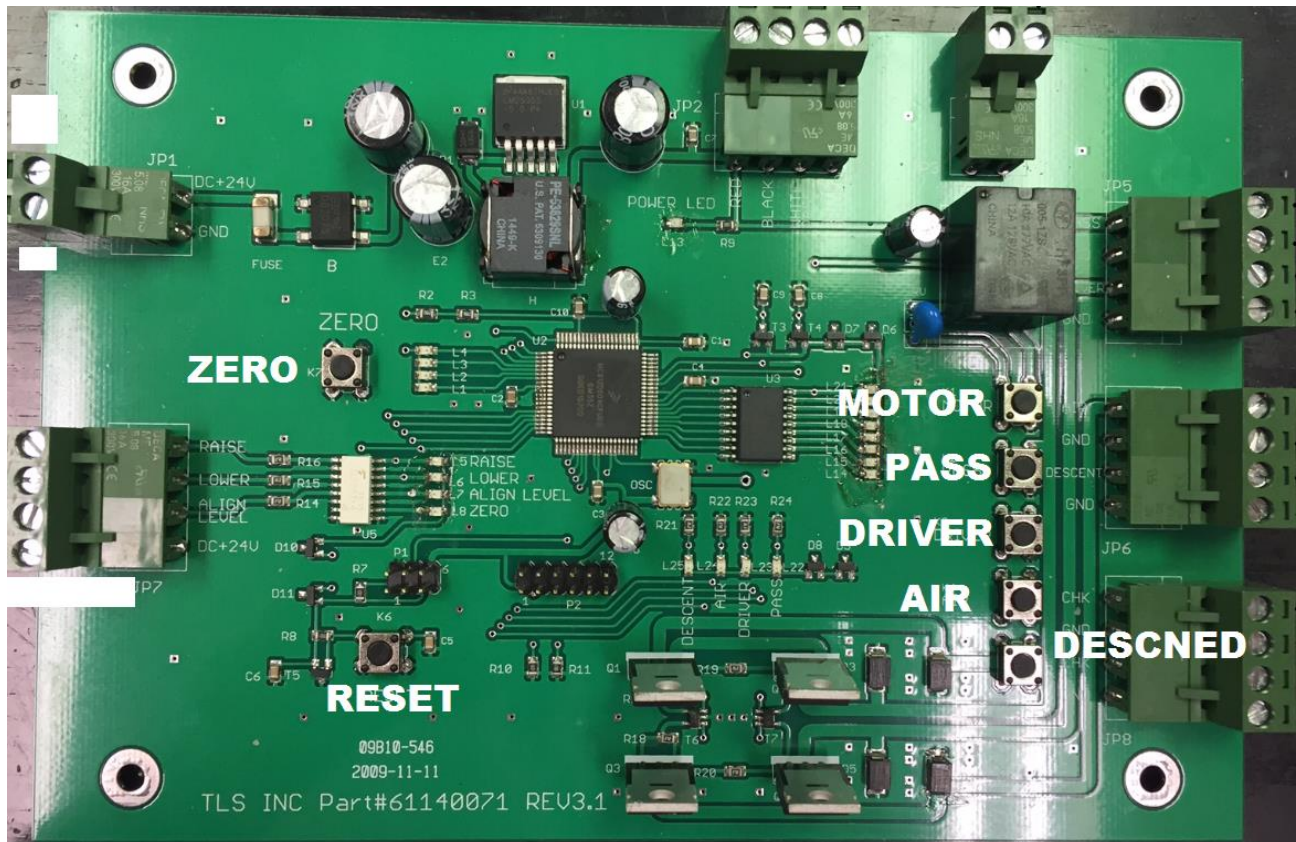

Manually Re-levelling Procedure:

The board will stop functioning if the two runways are out-of-sync at a certain distance. When this happens, the control buttons on the pendant or the console can not be used to bring the lift down to the floor.

Before working on the board, hydraulic line and potentiometer electrical cables must be inspected to make sure there is no hydraulic leakage and the electrical cables are not damaged.

Replace leaking hose or fittings and electrical cables if necessary.

To fully lower the lift:

1. Hit emergency stop button and wait for about 10 seconds, then release the emergency button to reboot the board.
2. Press and hold "Air" button on the board and observe the safety locks movement.
3. If any of the safety lock can't be lifted, press motor button for about 1 second to slightly raise the lift.
4. Identify the higher runway (driver side or passenger side).
5. If the **driver side is higher** than passenger side: hold "air" button and "driver" button together and press "descend" button (This should only bring the driver side runway down, if it doesn't, stop, and call factory) until the two runways are at the same level.
6. If the **passenger side is higher** than driver side: hold "air" button and "pass" button together and press "descend" button (This should only bring the passenger side runway down, if it doesn't, stop, and call factory) until the two runways are at the same level.
7. Press and hold "air" button and then press "descend". Two runways shall go down evenly. If not, stop and call factory.
8. Remove vehicle (if any) from the hoist.

To re-zero the lift:

1. Press the "motor" button until the lift passes the first (the lowest) safety lock. Press and hold "descend", "driver" and "passenger" buttons at the same time until both safety locks are fully engaged.
2. Press and hold "zero" button for about 3 seconds.
3. Use the buttons on the pendant or on the console to raise the lift, the lift should move evenly.

LIFT ILLUSTRATIONS and PARTS LISTS

The diagram below identifies main component parts and the order in which they are to be installed. Numbers correspond to installation diagrams found in the chart below and on following pages. Page numbers for each diagram is also found in the chart below. These diagrams, along with related parts lists, will assist you when installing and servicing this lift. Please insure these lift diagrams and parts lists are kept in a secure place for quick reference.

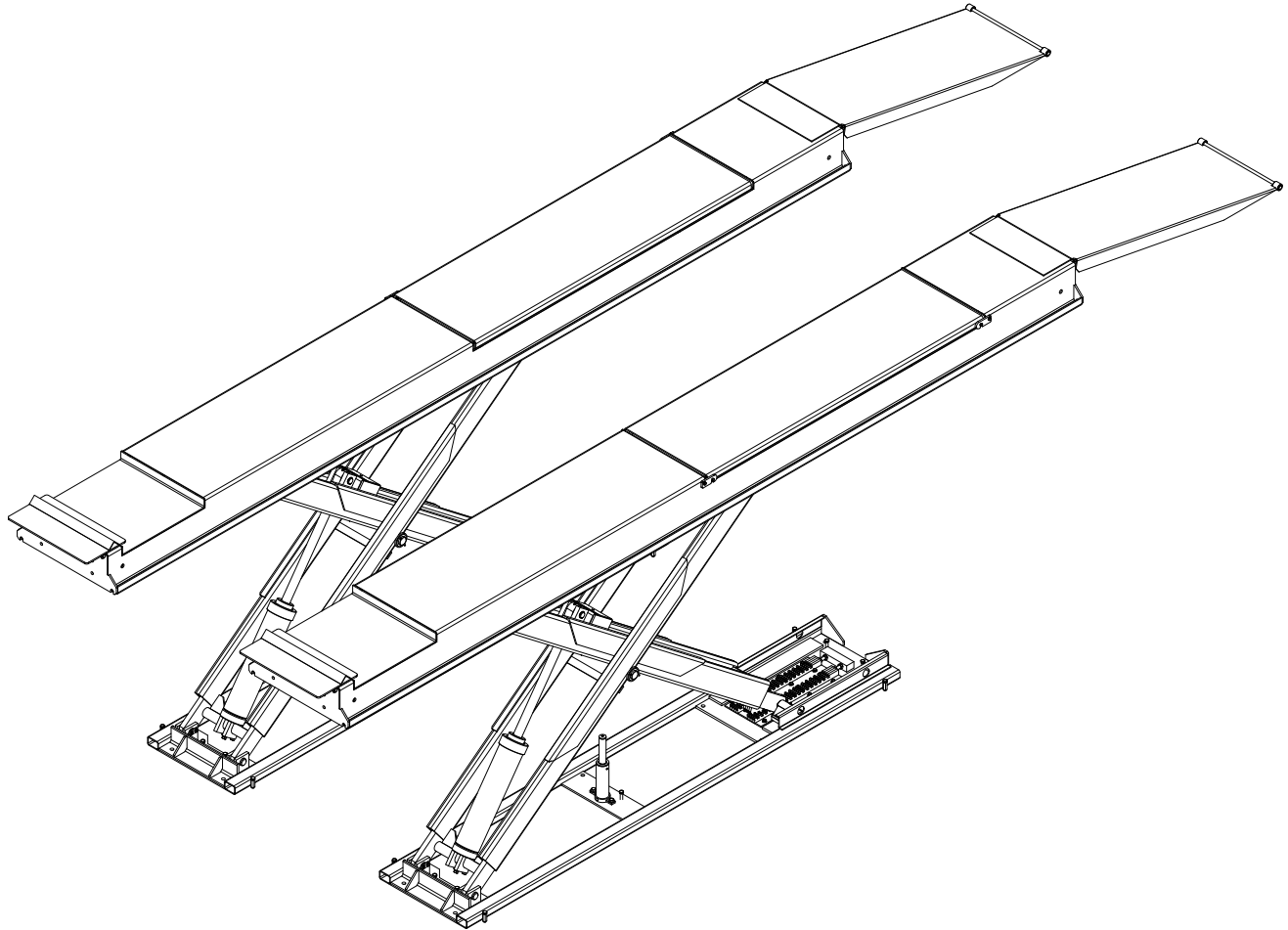
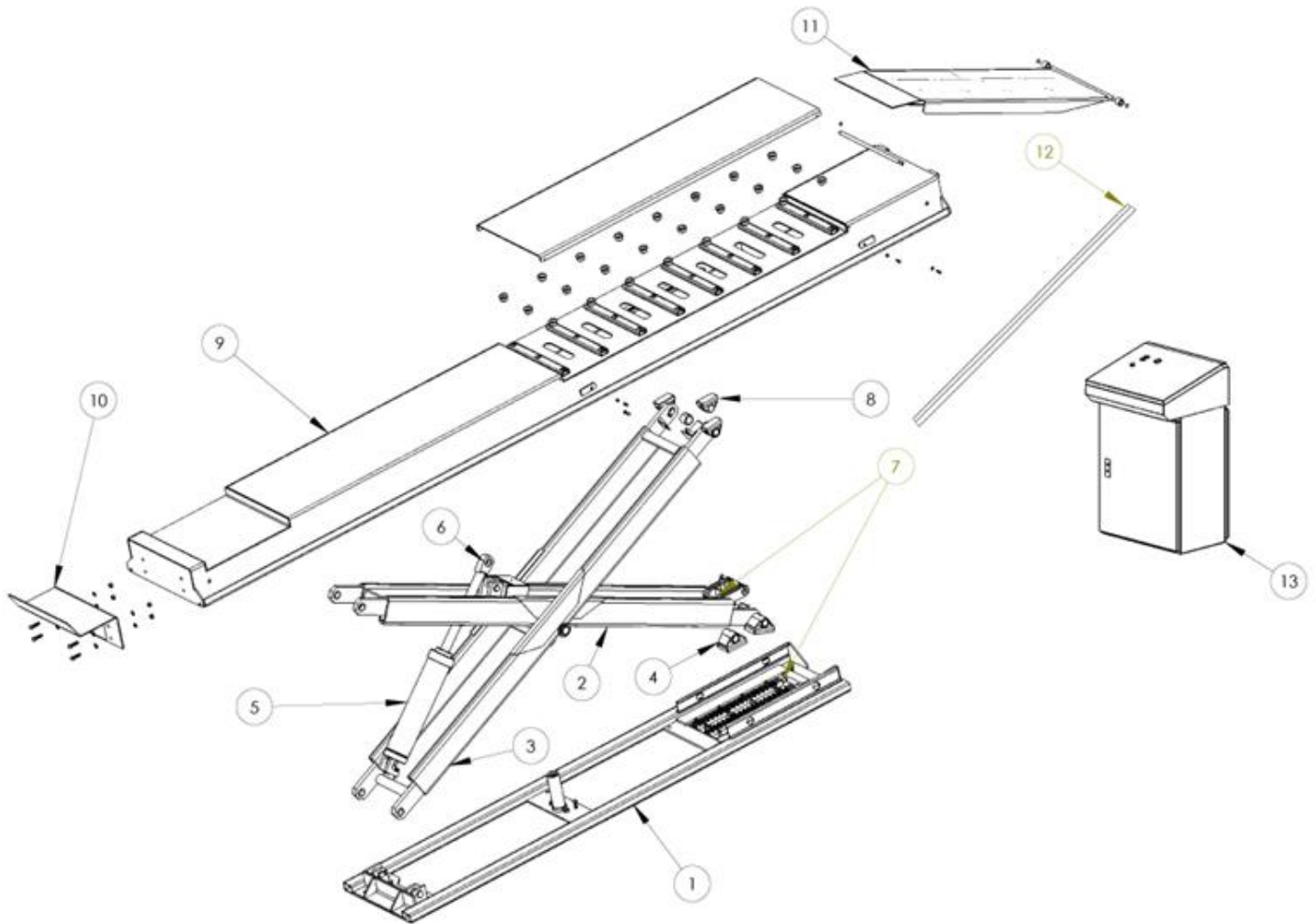
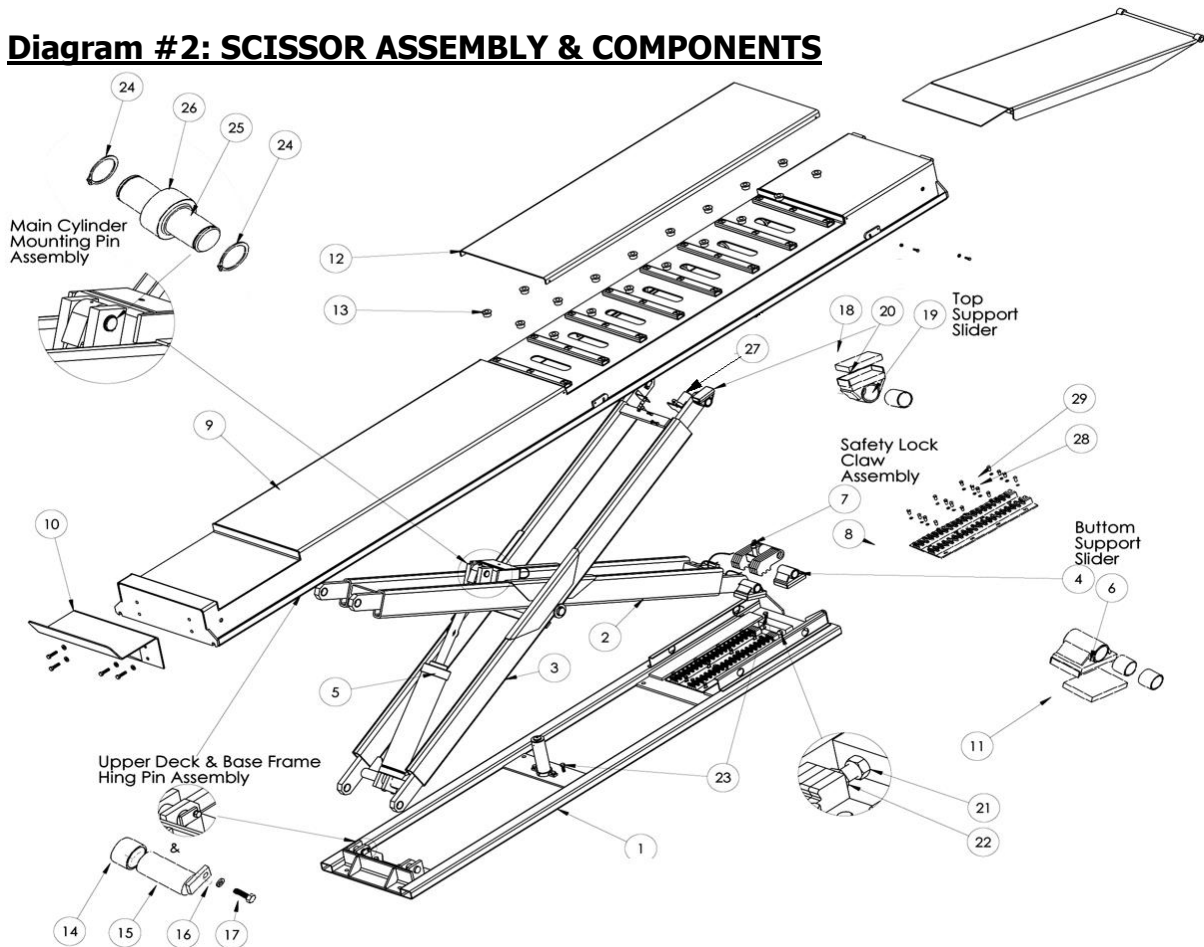

Diagram #1: MAIN COMPONENT ASSEMBLIES



Item Number	Part Number	Description	Qty
1	41140007	Base Frame Assembly	1
2	41140016	Scissor Drive Arm Assembly	1
3	41140017	Scissor Pull Arm Assembly	1
4	41140031	Bottom Support Slider	1
5	41140010	Main Hydraulic Cylinder	1
6	21140006	Main Cylinder Rod Weldment	1
7	41140021	Safety Locking Claw System	1
8	41140032	Top Support Slider	1
9	41140005	Deck Assembly	1
10	41140015	Wheel stop Assembly with Fasteners	1
11	41140014	Pivoting Ramp Assembly	1
12	31140014	Line Cover	1
13	41140002	Console Power Unit	1
	44140034	Wall Mount Style Power Unit (with Pendant)	1

Diagram #2: SCISSOR ASSEMBLY & COMPONENTS



Item	Part Number	Description	Qty.
1	41140007	BASE FRAME ASSEMBLY	
2	41140012	SCISSOR DRIVE ARM ASSEMBLY	2
3	41140013	SCISSOR PULL ARM ASSEMBLY	2
4	41140031	BOTTOM SUPPORT SLIDER	4
5	41140010	MAIN HYDRAULIC CYLINDER	2
6	31140052	1.75"OD x 1.5"ID.1.5"L OIL IMPREGNATED	4
7	41140021	SAFETY LOCKING CLAW SYSTEM	2
8	21140031	RACK WELDMENT W / SAFETY PLATE	2
9	41140005	DECK SUB ASSEMBLY	2
10	41140015	WHEEL STOP ASSEMBLY	2
11	11140051	BOTTOM SLIDER PLATE MAT: UHMW	4
12	11140013	SLIP-PLATE SKIN	2
13	31140005	7/8" BALL TRANSFER (SKF)	24
14	31140051	ID 1.5" x OD 1.75" x 1 1/8"LG BRONZE BUSHING (OIL)	4
15	21140026	ROLLER 1.5 DIA PIN ASSEMBLY/ (BOTTOM & TOP)	4
16	3C140029	5/16" SPRING WASHER (LW 0.3125)	4
17	3C140035	5/16-NC x 1 BOLT	4
18	11140052	TOP SLIDER PLATE MAT: UHMW	4
19	31140053	1.5" x 1.75" x 2"L BRONZE BUSHING (Oil Impregnated)	4
20	41140032	TOP SUPPORT SLIDER	4
21	3C140036	5/8-NC x 2 BOLT (Base Frame Stop)	4
22	3C140059	1/2 HEX NUT GR.5	4
23	3C140040	1/2-NC x 2 BOLT (Base Frame Leveling)	6
24	3C140049	EXT.CLIP RING FOR 1-1/4" DIA SHAFT	4
25	11140033	MAIN CYLINDER MOUNTING PIN	2
26	31140072	SPHERICAL PLAIN BEARING, #12SF 20	2
27	31140044	STRING POTENTIOMETER S/N: 38021365	2
28	3C140037	3/8-NC x 3/4" L SOC. HD. CAP SCREW	16
29	3C140030	3/8" SPRING WASHER	16

Diagram #3: SCISSOR ASSEMBLY and HYDRAULICS

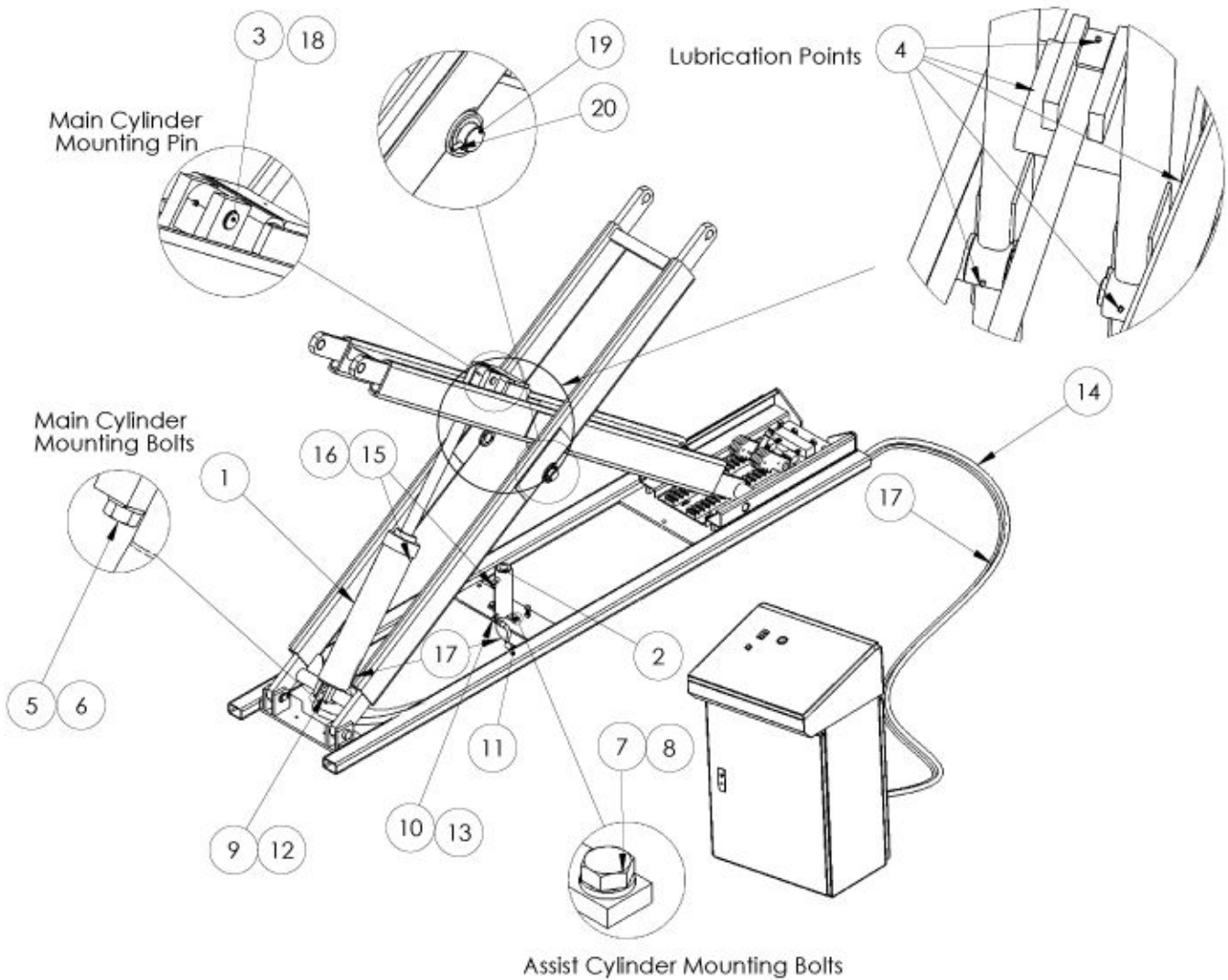

Diagram #3: SCISSOR ASSEMBLY and HYDRAULICS PARTS LIST

Item	Part Number	Description	Qty.
1	41140010	Main Cylinder	2
2	41140012	Assist Cylinder (2019 New Version)	2
3	11140033	Main Cylinder Mounting Pin	2
4	31140013	GF-641 Hydraulic Grease Fitting 1/4 - 20 UNC	10
5	3C140039	1" x 3.5 L Hex Bolt	2
6	3C140031	1/2" Spring Lock Washer	4
7	3C140034	1/2-13 x 1" Hex. Bolt	4
8	3C140031	1/2" Spring Lock Washer	4
9	31140033	3/8 S-Fitting Male x 3/8' Male Pipe Conn.	2

Diagram #3: SCISSOR ASSEMBLY and HYDRAULICS PARTS LIST (cont'd)

Parts List Continued from Page 20			
Item	Part Number	Description	Qty.
10	31140043	1/4 Male x 1/4" M NPT	2
11	31140035	3/8" x 3/8" x 3/8" Male Union Tee	2
12	31140032	3/8" x 48" Hose SAE 100R17 210BAR (3045PSI)	2
13	31140037	1/4 and 3/8 Hose 10.5"L (3045psi) SAE 100R17 210BAR	2
14	31140038	3/8 Hose 30'L 4506 SAE 100R17 210 BAR (3045 PSI)	2
15	31140019	Elbow Fitting KQ2L11-35S	4
16	31140018	1/8" Poly Tube For 1/8" Oil Return Fitting	2
17	31140017	1/8" Poly Tube For 1/8" Oil Return Fitting	2
18	3C140049	Ext. Clip Ring For 1-1/4" DIA. Shaft	4
19	11140034	Center Hinge Pin	4
20	31140012	1/4" DIA. x 2-1/2" L Spring Pin (slotted) SPS 0.25x2.5	4

Diagram #4: CONSOLE HYDRAULIC PARTS LIST

Item	Part Number	Description	Qty.
1	61140021	HYDRAULIC DRIVE MOTOR ,3HP	1
2	61140022	HYDRAULIC TANK	1
3	61140022	CAP WITH HYDRAULIC TANK	1
4	31140045	3/8 HYDRAULIC HOSE 15" LENGTH 4506 SAE 100R17 210BAR	1
5	31140046	1/4" HYDRAULIC HOSE 15" L761-4-REEL 738-44 FITTING	1
6	31140047	5/32 POLYURETHANE TUBING WITH FITTINGS	2
7	61140004	90 ELBOW ADAPTER SAE 070220 2503-6-6	2
8	61140001	MANIFOLD (FLOW DIVIDER-COMBINER) 2007F03-05455-01	1
9	31140110	AIR REGULATOR C/W GAUGE	1

Diagram #4: CONSOLE HYDRAULIC CONNECTIONS

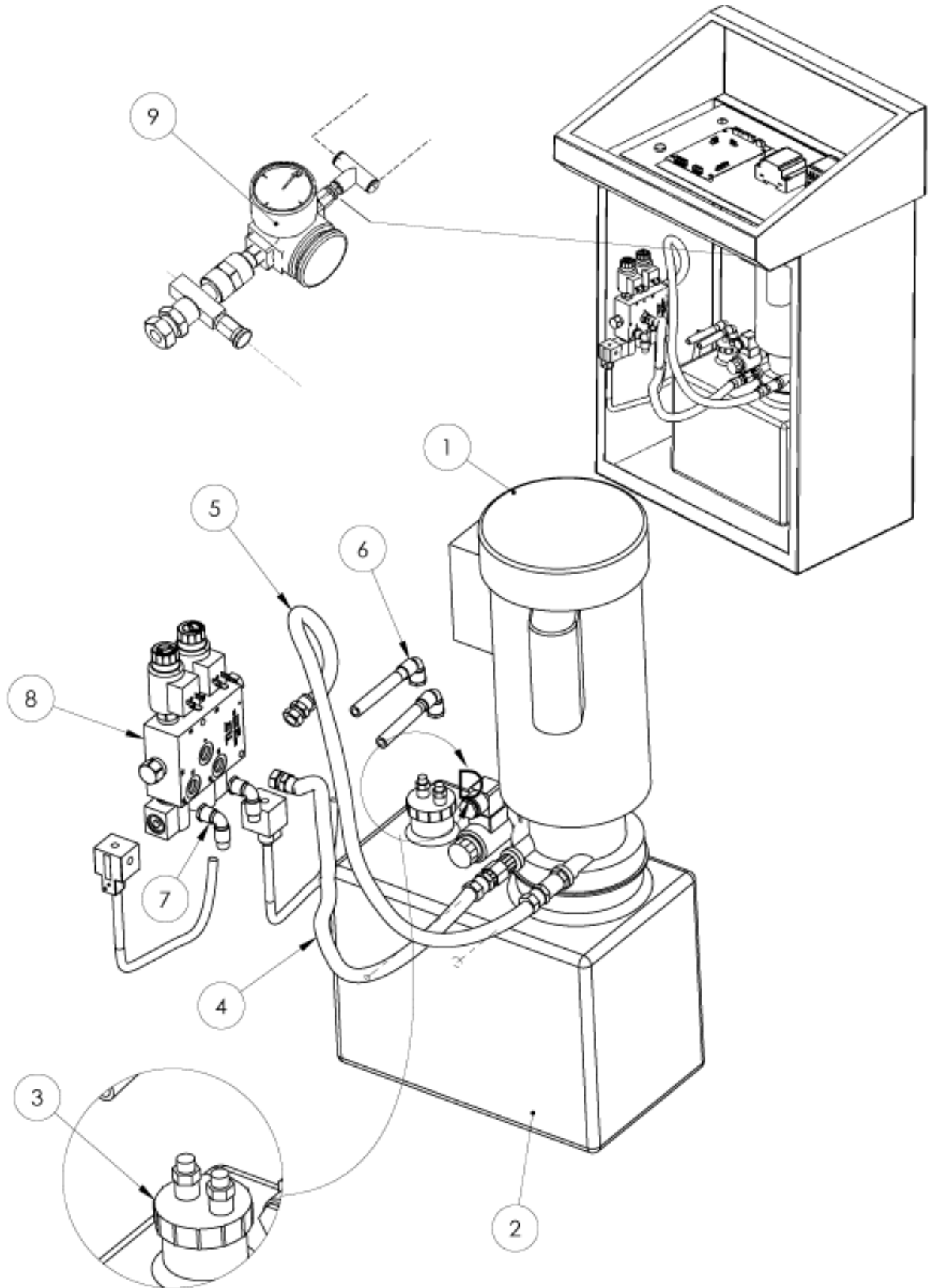

Diagram #5 : AIR SYSTEM CONNECTIONS and COMPONENTS

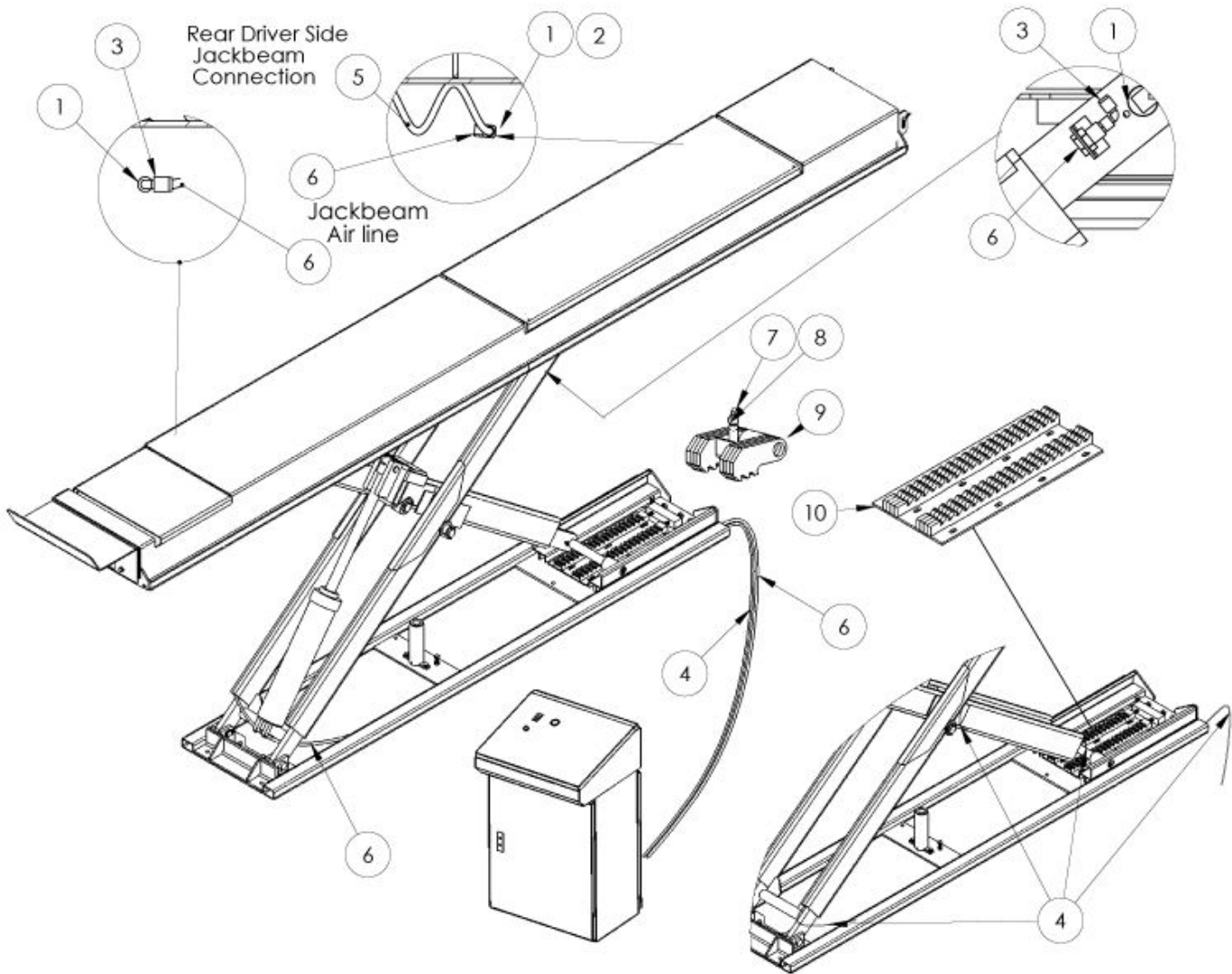

Diagram #5: AIR SYSTEM COMPONENT PARTS LIST

Item	Part Number	Description	Qty
1	31140024	1/4" x 1"LG NPT BULKHEAD (TERMINAL BOLT 14958-S 1/4)	3
2	31140030	AIR NUT CAP / FLAT WASH	1
3	31140023	3/8 SWIVEL ELBOW CAMOZZI #6520-06-4	2
4	31140018	5/32" POLY TUBE FOR BREATH 1/8 ELBOW FITING 10' Long	2
5	31140021	NYLON 3/8" COILED HOSE N14-12B	3
6	31140028	3/8" BLACK POLYURETHANE TUBING 1A-152-01	2
7	31140019	5/32 x 1/8 ELBOW FITING KQ2L11-35S BREATH FITTING	2
8	31140054	AIR CYLINDERS 3/4"BORE x 1" STROKE	2
9	41140021	SAFETY LOCKING CLAWS SUB_ASSY	2
10	21140031	RACK WELDMENT W / SAFETY PLATE	2

Diagram #6a: LOW VOLTAGE CONSOLE CONNECTIONS TOP VIEW (1 PHASE)

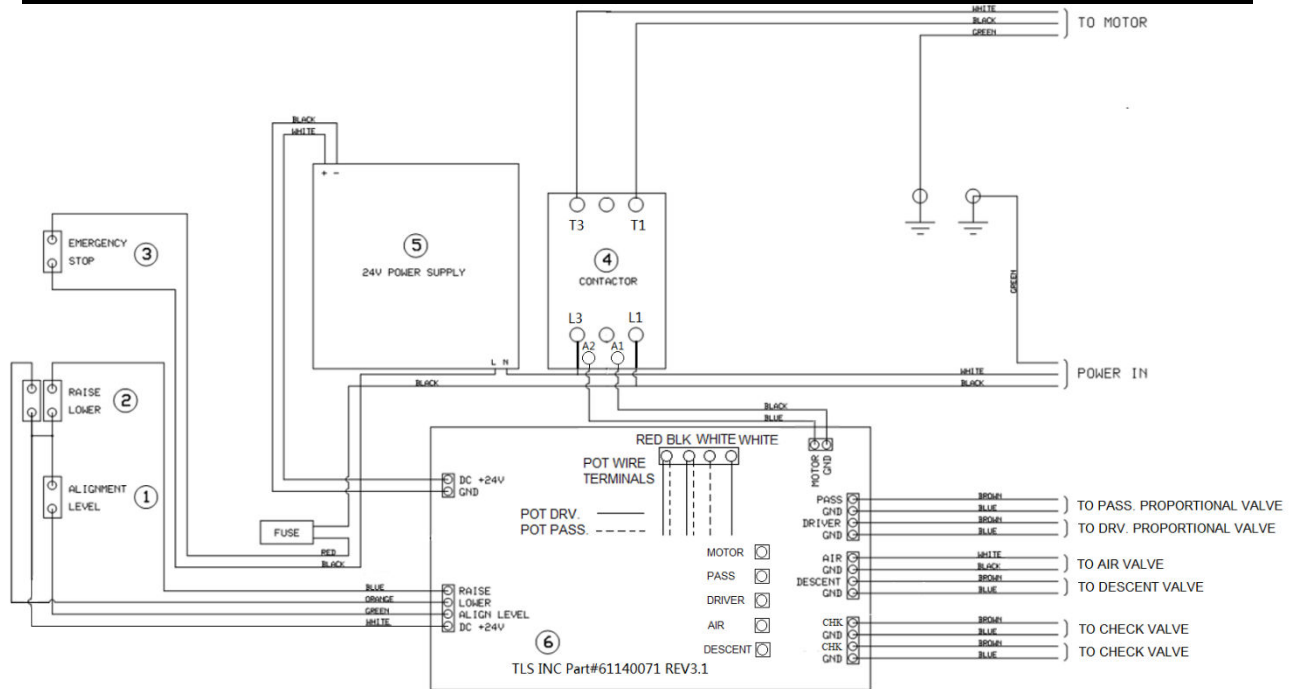

Diagram #6b: LOW VOLTAGE CONSOLE CONNECTIONS TOP VIEW (3 PHASE)

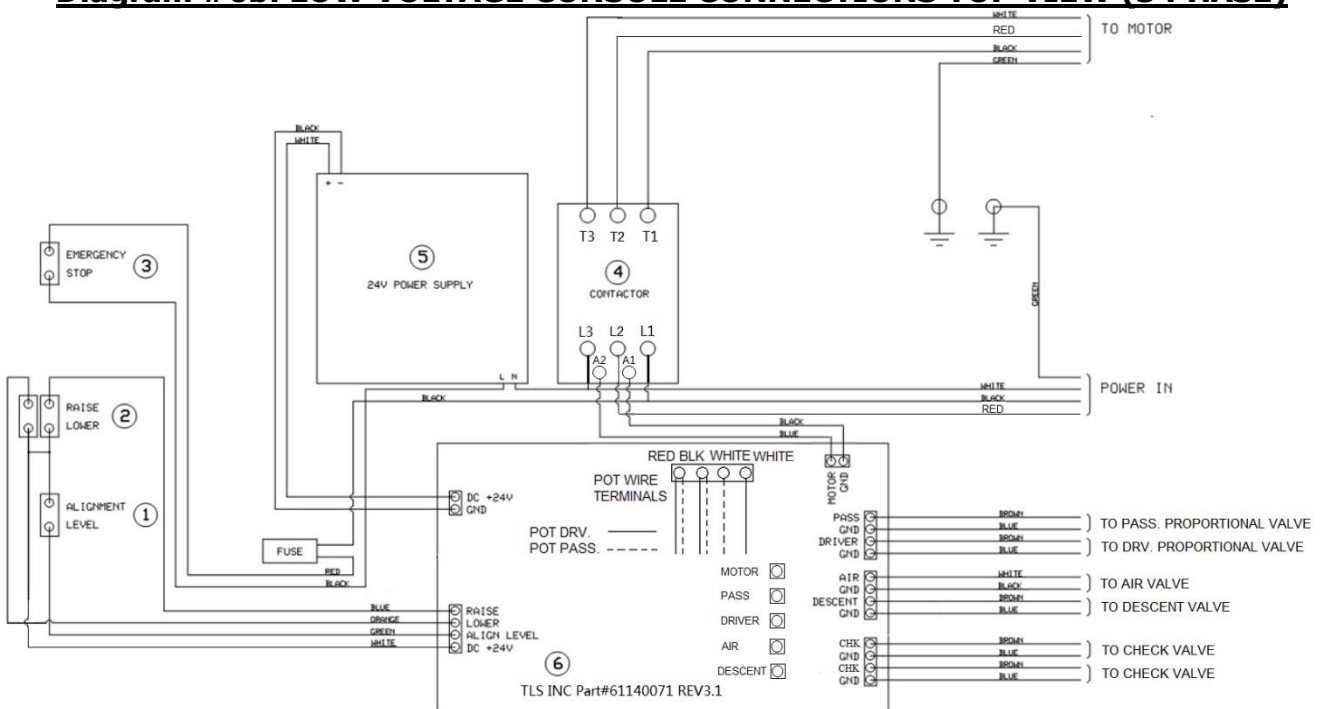

Diagram #6: LOW VOLTAGE CONSOLE COMPONENT PARTS LIST

Item	Part Number	Description	Qty
1	61140075	ALIGNMENT LEVEL BUTTON	1
2	61140073	SWITCH (UP/DOWN)	1
3	61140074	RED EMERGENCY STOP PUSH/PULL BUTTON	1
4	61140076	24VDC CGC - 32D CONTACTOR UNIT	1
5	61140072	POWER SUPPLY,24V	1
6	61140071	SCISSOR LIFT CONTROLLER UNIT	1

Diagram #7 : CONSOLE COMPONENT PARTS LIST

Item	Part Number	Description	Qty
1	61140076	CONTACTOR UNIT CGC - 32D-24VDC	1
2	61140072	POWER SUPPLY,24V	1
3	61140071	SCISSOR LIFT CONTROLLER UNIT	1
4	61140002	24VDC PROPORTIONAL FLOW CONTROL VALVE 0.75GPM	2
5	61140001	MANIFOLD FLOW DIVIDER-COMBINER	1
6	61140023	3/8 HYDRAULIC HOSE 15" LENGTH (Link PUMP and MANIFOLD)	1
7	61140024	3/8 HYDRAULIC HOSE 21" LENGTH (Link PUMP and MANIFOLD)	1
8	61140021	HYDRAULIC DRIVE MOTOR ,3HP (LEESON)	1
9	31140047	FLOW RETURN INLET: 5/32 POLYURETHANE TUBING WITH FITTINGS	2
10	31140024	AIR SUPPLY FOR JACK BEAM 1/4" x 1"LG NPT BULKHEAD	1
11	31140110	AIR REGULATOR C/W GAUGE	1
12	61140004	90 ELBOW ADAPTER SAE 070220 2503-6-6	2
13	31140109	Solenoid Air Valve	1

Diagram #7 : CONSOLE COMPONENTS AND CONNECTIONS

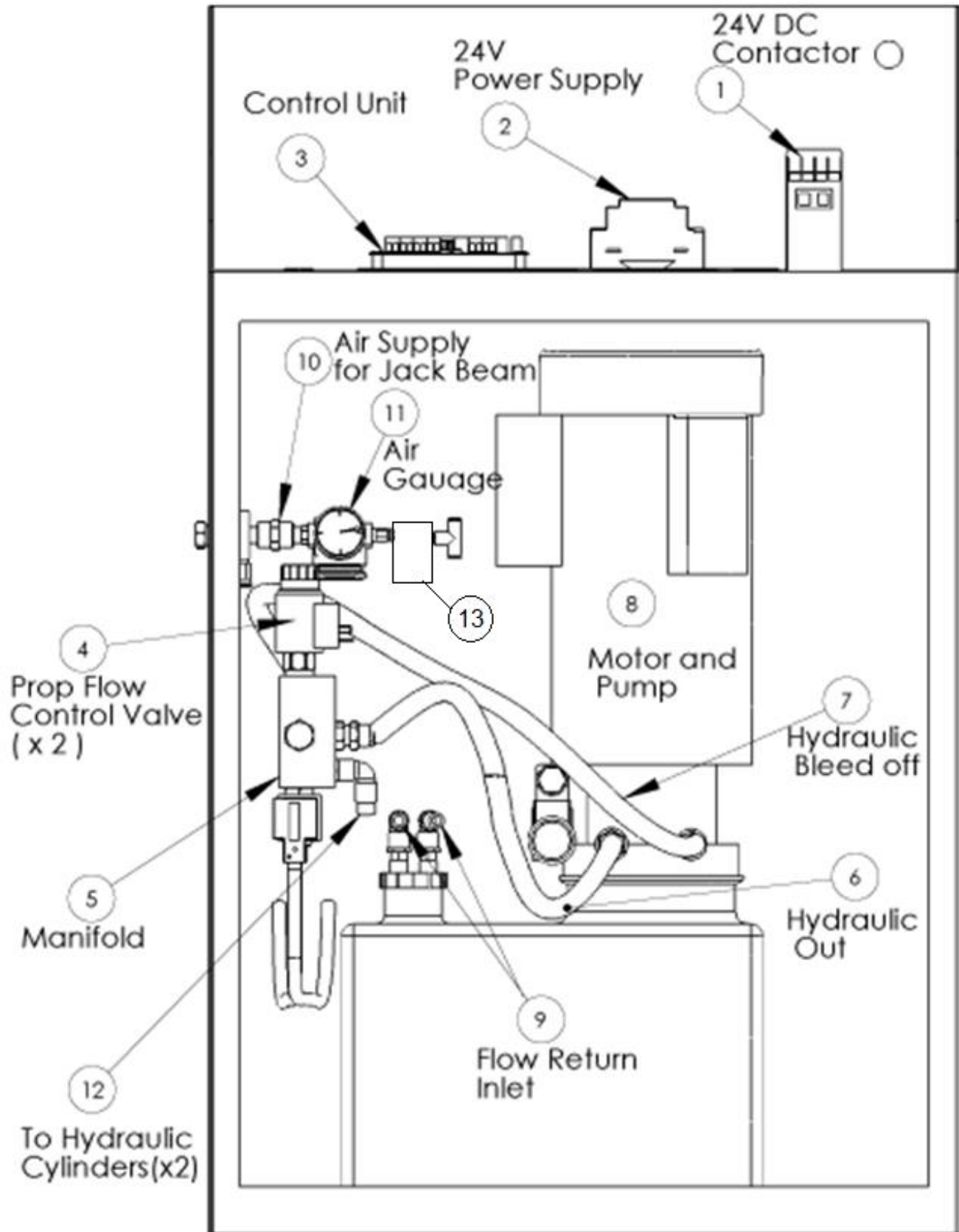
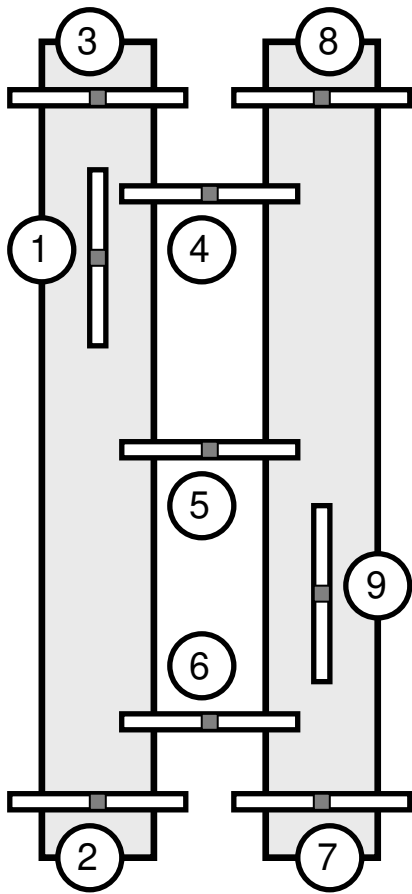
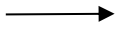
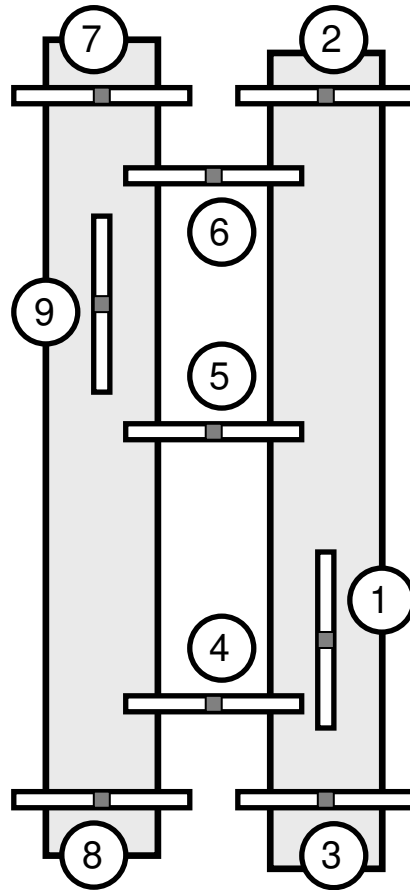
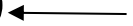

Diagram #8: LEVELING PROCEDURE

Example #1
leveling start
point if highest
point on both
decks is here



Example #2
leveling start
point if highest
point on both
decks is
here



Base Frame and Down Position Runway Leveling

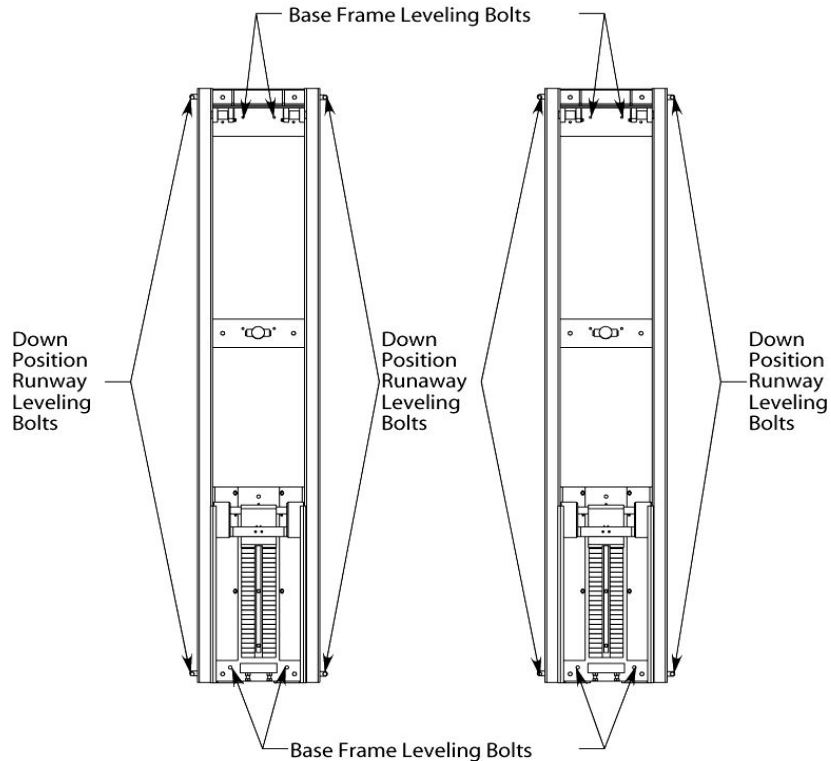
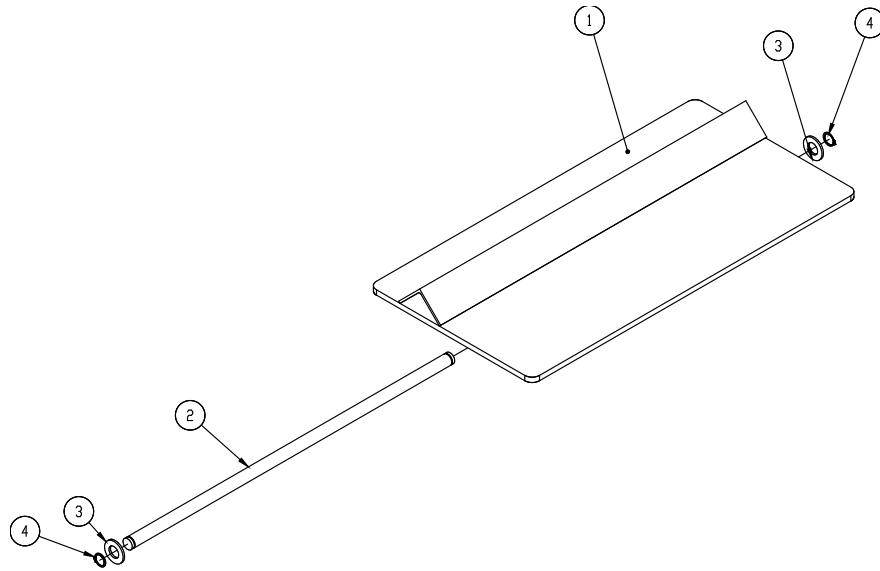

Diagram #9: WHEEL STOP and REAR APPROACH RAMP



Front Wheel Stops

Item	Part Number	Description	Qty
1	24180014	WHEEL STOP WELDMENT	2
2	11140128	PIVOTING PIN	4
3	3C100019	5/8 NARROW FLAT WASHER	4
4	3C100017	5/8 SNAP RING	8

Rear Approach Ramps

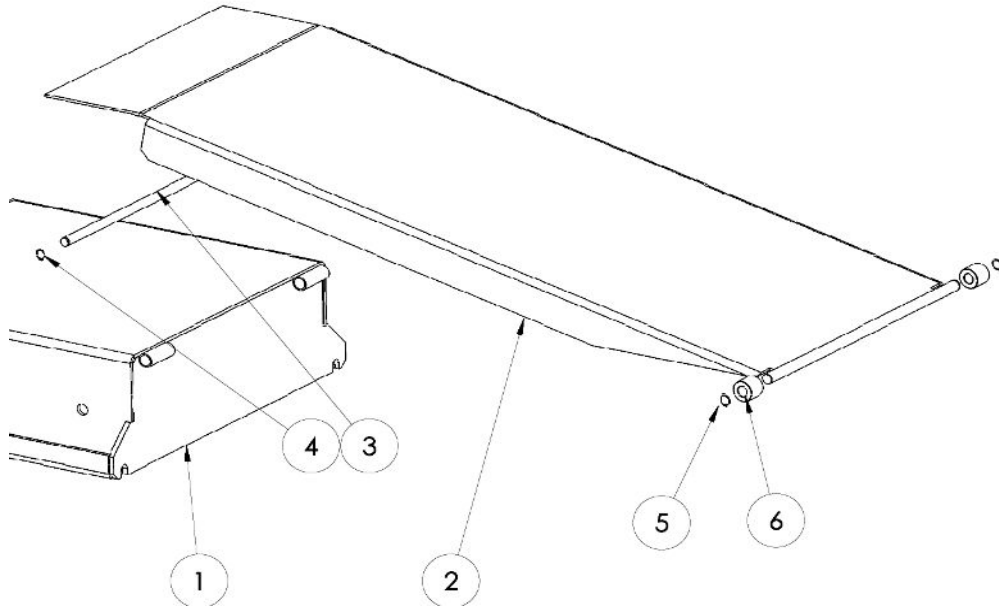

Item	Part Number	Description	Qty
1	44140005	SCISSOR LIFT DECK	2
2	21140100	APPROACH RAMP WELDMENT	2
3	11140128	PIVOTING PIN	4
4	3C100017	5/8 SNAP RING	8
5	3C100018	3/4 SNAP RING	4
6	11140126	ROLLER	4

Diagram #10: SAFETY DECAL APPLICATION

Automotive Lift Institute, Inc.

<p>CAUTION</p> <p>Lift to be used by trained operator ONLY.</p>	<p>CAUTION</p> <p>Authorized personnel only in lift area.</p>
--	--

The messages and pictographs shown are generic in nature and are meant to generally represent hazards common to all automotive lifts regardless of specific style.
 Funding for the development and validation of these labels was provided by the Automotive Lift Institute, PO Box 85 Cortland, NY 13045.
 Replacement label sets may be obtained from the original lift manufacturer and ALI's member companies. They are protected by copyright.
 www.autolift.org ©1992 by ALI, Inc. ALIWL200

<p>SAFETY INSTRUCTIONS</p> <p>Read operating and safety manuals before using lift.</p>	<p>SAFETY INSTRUCTIONS</p> <p>Proper maintenance and inspection is necessary for safe operation.</p>
---	---

<p>SAFETY INSTRUCTIONS</p> <p>Do not operate a damaged lift.</p>	<p>The messages and pictographs shown are generic in nature and are meant to generally represent hazards common to all automotive lifts regardless of specific style. Funding for the development and validation of these labels was provided by the Automotive Lift Institute, PO Box 85 Cortland, NY 13045. Replacement label sets may be obtained from the original lift manufacturer and ALI's member companies. They are protected by copyright. www.autolift.org ©1992 by ALI, Inc. ALIWL200</p>
---	---

WL200 Series Label Kit

<p>WARNING</p> <p>Clear area if vehicle is in danger of falling.</p>	<p>WARNING</p> <p>Remain clear of lift when raising or lowering vehicle.</p>
---	---

<p>WARNING</p> <p>Keep clear of pinch points when lift is moving.</p>	<p>WARNING</p> <p>Keep feet clear of lift while lowering.</p>
--	--

<p>WARNING</p> <p>Do not override self-closing lift controls.</p>	<p>WARNING</p> <p>Chock wheel to prevent vehicle movement.</p>
--	---

The messages and pictographs shown are generic in nature and are meant to generally represent hazards common to all automotive lifts regardless of specific style.
 Funding for the development and validation of these labels was provided by the Automotive Lift Institute, PO Box 85 Cortland, NY 13045.
 Replacement label sets may be obtained from the original lift manufacturer and ALI's member companies. They are protected by copyright.
 www.autolift.org ©1992 by ALI, Inc. ALIWL200

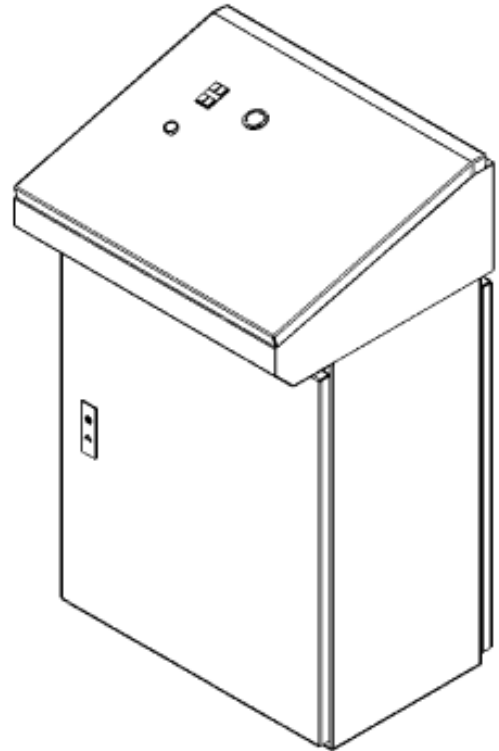

AUTOMOTIVE LIFT SAFETY TIPS

These safety tips when used will be a constant reminder to your lift operator. The information specific to each lift, always refer to the lift manufacturer's manual.

1. Inspect your lift daily. Never operate if it malfunctions or if it has broken or damaged parts. Repairs should be made with original equipment parts.
2. Operating controls are designed to close when released. Don't back open or override them.
3. Never overload lift. Manufacturer's rated capacity is shown on nameplate attached to the lift.
4. Positioning of vehicle and operation of the lift should be done only by trained and authorized personnel.
5. Never raise vehicle with anyone inside it. Customers or bystanders should not be in the lift area during operation.
6. Always keep lift area free of obstructions, grease, oil, trash and other debris.
7. Before driving vehicle over lift, position area and supports to provide undisturbed clearance. Do not do so over 48" arms, obstructions, or area supports. This could damage lift or vehicle.
8. Load vehicle on lift carefully. Position lift supports to contact at vehicle manufacturer's recommended lifting points. Raise lift and support vehicle. Check supports for secure contact with vehicle. Raise lift to desired working height. **CAUTION:** If you are working under vehicle, lift should be raised high enough for locking device to be engaged.
9. From the safe work position, the removal of manufacturer's components may cause a vehicle shift in the case of gravity, and could result in raised vehicle instability. Refer to the vehicle manufacturer's correct repair/recommended procedures when vehicle components are removed.
10. Before lowering lift, the same final steps, chocks, etc., are removed from under vehicle. Release locking device before attempting to lower lift.
11. Before lowering vehicle, ensure that position of area and supports is provided an unobstructed exit (See item #7).
12. These "Safety Tips" along with general lift safety materials, are provided on all industry vehicles by the Automotive Lift Institute. Visit our web site at www.autolift.org for more information on the material, or write to P.O. Box 85, Cortland, NY 13045.

Look For This Label on all Automotive Service Lifts.



AUTOMOTIVE LIFT INSTITUTE

www.autolift.org

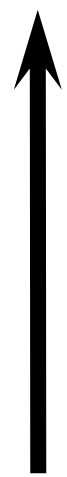

LIFT SAFETY and LIFT MAINTENANCE MUST BE PART OF YOUR DAILY ROUTINE

The above information will assist you with purchasing grout material from a local source. The grout material you purchase should meet or exceed these specifications.

**SINCE
1908**

**All Purpose
Anchoring Compound**

1. Product Description

a. Basic Use: Instarok Cement is a dry cement powder which when mixed with water hardens rapidly to a permanent, solid mass that is not affected by moisture, rain or submersion in water. With nearly three times the strength of concrete, Instarok Cement anchors, patches and repairs in one hour or less.

b. Features/Benefits:

- Can be poured or troweled.
- Expands slightly as it sets - locks permanently.
- Safe to use without danger of burns or other injury to workers.
- Free from iron - no rust staining.
- Immune to oil, grease and solvents.
- Dries to a light gray color.
- Good for interior or exterior uses.
- No added calcium chloride or corrosive agents.

c. Typical Applications: Railings, posts, bolts, poles, parking meters, light machine anchors, cracks, holes, pointing masonry and pipe sleeves.

d. Limitations: Do not use Instarok Cement below 40°F (4°C). (Note: When durability is needed for exterior patching, use Thinpave, Thickpave or Speedpave.)

e. Composition: Instarok Cement is an expansive hydraulic cement system along with proprietary chemical ingredients.

f. Color/Appearance: Similar to concrete.

2. Packaging

Instarok Cement is packaged in 10-lb. (4.5 Kg) tubs, 25-lb. (11.3 Kg) pails, 50-lb. (22.7 Kg) pails, and 125-lb. (56.7 Kg) drums.

3. Estimating/Yield

Size of Container	Yield
10-lb. (4.5 Kg)	0.10 cu. ft. (0.003 cu. m)
25-lb. (11.3 Kg)	0.25 cu. ft. (0.007 cu. m)
50-lb. (22.7 Kg)	0.50 cu. ft. (0.014 cu. m)
125-lb. drum (56.7 Kg)	1.25 cu. ft. (0.035 cu. m)

4. Technical Data

a. Compressive Strength: ASTM C 109, 2 in. (50 mm) cubes at 72°F (22°C).

Age	Strength
1 hour	2,000 psi (14 MPa)
1 day	5,000 psi (34 MPa)
3 days	5,500 psi (38 MPa)
7 days	6,000 psi (41 MPa)
28 days	7,000 psi (48 MPa)

b. Set Times: ASTM C 191

Initial Set: 30 minutes.

Final Set: 40 minutes.

c. Tensile Test: 1/2 in. (12.7 mm) diameter bolt at 1 hour: bolt fracture.

d. Expansion: ASTM C 157; +0.10% at 90 minutes.

5. Directions for Use

a. Preparation: Contact surfaces of concrete or masonry must be clean, sound and textured. Chip or chisel to get to sound concrete. Bolts, anchors, or rails should be clean and free of oil or grease. Blow off any dirt or dust from contact areas with compressed air.

b. Bonding: No bonding agent is required. Pre-dampen contact surfaces before Instarok Cement installation.

c. Mixing: Mix only as much Instarok Cement as is needed for the job or that can be placed in 15 minutes. Use approximately 3 pints (1.4 liter) of water for each 10 lbs. (4.5 Kg) of Instarok Cement. Mix to a smooth, pourable consistency by hand.

d. Placing: Pour Instarok Cement into bolt hole, rail blockout, or annular space around pole.

e. Curing: Cover with wet burlap or wet rags for one hour. Cure with one coat of Seal N Kure or Metcure.

f. Maintenance: No maintenance is normally needed. Instarok Cement may be sealed or coated with standard concrete products.

6. Availability

Instarok Cement is normally available immediately from your local distributor.

Metalcrete Industries

10330 Brecksville Road • Cleveland, Ohio 44141
440-526-5600 • 800-526-5602 • FAX 440-526-5601