

coats

*Engineered to Perform.
Designed to Last.*



MAXX 70 TIRE CHANGER

BUILT ON THE BEST PLATFORM IN THE BUSINESS



MAXX RIM/CLAMP

The Coats® Maxx picks up where the X-Series left off but goes further. This unit has been completely redesigned from the ground up based on extensive customer R&D and represents what it takes to make it in the high-volume tire business.

- ✓ WIDER, MORE ROBUST CHASSIS
- ✓ MORE POWER, MORE FEATURES
- ✓ IMPROVED SPEED AND RELIABILITY



6" - 24" EXTERNAL CLAMPING DIAMETER



HAND OPERATED BEAD LOOSENER



220V 2HP AND 110V ELECTRIC OR AIR MOTOR



74"W X 86"H X 44"D

POWERFUL DYNAMIC FEATURES

DURABLE AND RELIABLE

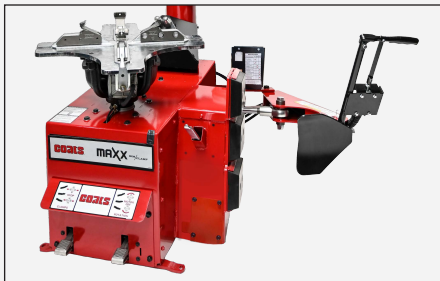

More Robust Chassis

Tested up to 250,000 bead breaking cycles for ultimate durability in the harshest working environments.

BETTER BEAD SEALING

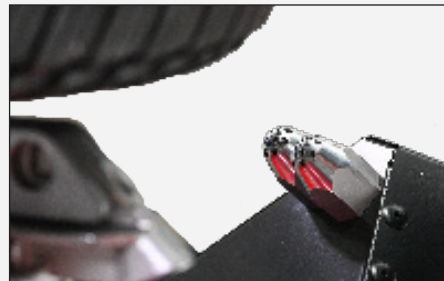

Dual Nozzle Bead Sealer

Seal difficult assemblies with ease with more air, more quickly.

TIME SAVER

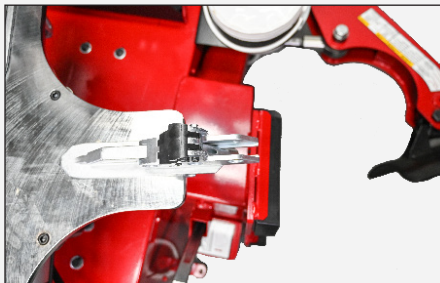

No-Index Tabletop

Save time by not having to index the tabletop when working on large assemblies, reducing pedal presses and allowing techs to keep moving.

POWER WHEN YOU NEED IT



220V 2HP Power Option

With high torque 220V 2HP motor you can power through tough assemblies.

PATENTED TOOL HEADS

Our patented tool heads work hard so you don't have to. The Maxx 70 features our Polymer Duckhead and Robo Arm Bead Depressor to make changing tires a breeze.



ROBO ARM BEAD DEPRESSOR



Tool used to push the tire bead into the drop center of the rim, allowing for effortless mounting and dismounting of the tire.

POLYMER DUCKHEAD



Tool used for mounting and demounting tires without damaging the rim.



SEE THE MAXX 70
IN ACTION

MOUNT & DEMOUNT TIRES WITHOUT DAMAGE

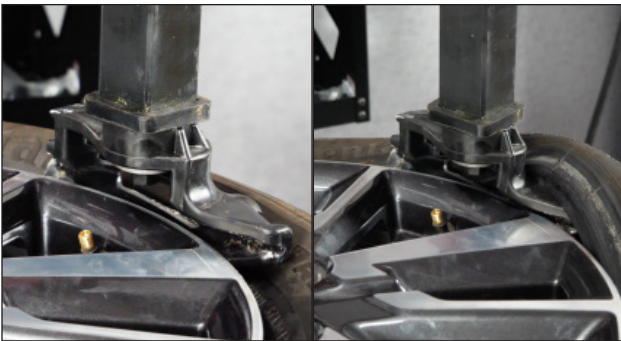

MAINTAIN DROP CENTER & LIFT HEAVY ASSEMBLIES



SIMPLE CONTROLS SIMPLE CONTROLS MAKE IT EASY

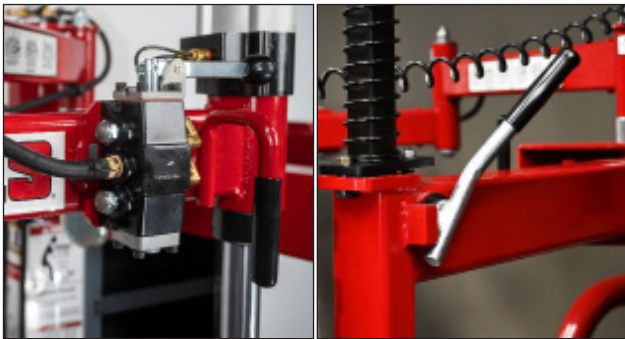

SHOP TYPES



HIGH VOLUME TIRE DEALERS
OR GENERAL REPAIR SHOPS

TIRE TYPES



- ✓ OE PASSENGER
- ✓ LIGHT TRUCK & SUV
- ✓ MEDIUM-DUTY TRUCK

POWER / TORQUE



STRONG, ROBUST RIM CLAMP
TIRE CHANGER



SPEED + POWER + DURABILITY + RELIABILITY + CAPABILITY

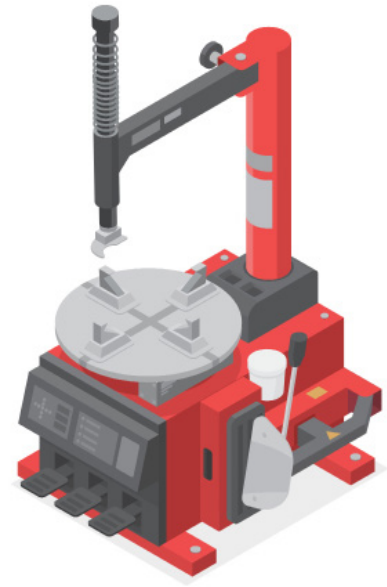

Maxx 70

"The Other Guys"

Machine Style	Tabletop Rim Clamp	✓	Tabletop Rim Clamp
Mount/Demount Tool	Polymer Mount Head	✓	Polymer Mount Head
Capacity	6-30" External* (24" Total Range)	✓	10-26" External (16" Total Range)
Max Width	16"	✓	14"
Tire Max Diameter	50"	✓	43"
Bead Loosening Type	Hand Control Shovel	✓	Push Button Hand Shovel Only
Bead Loosener Width	Up to 22" Wide	✓	Only 16"
Pressing Devices	Robo-Arm		Bead Press
Secondary Inflation	Double Single Point	✓	Optional Hose
Motors	Electric: 2HP, 220V, 60 Hz Electric: 110V Air: Air Motor, 110-175 psi, 15 scfm	✓	220V 1HP
Power	220V or 110v	✓	220V
Footprint	74" w x 86" h x 44" d		55" w X 82" h X 58" d

*With optional Extended 30" Clamps

DUAL NOZZLE INFLATION SYSTEM



UP TO 16" WHEEL WIDTH

220V 2HP ELECTRIC
MOTOR

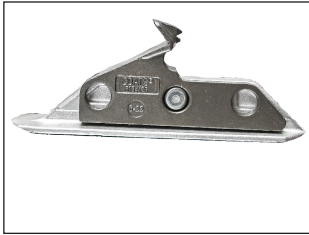

STEEL CLAMPS
6" - 24" WHEELS

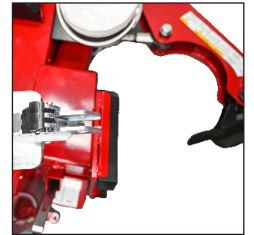

NO INDEX
TABLETOP

WIDE CHASSIS

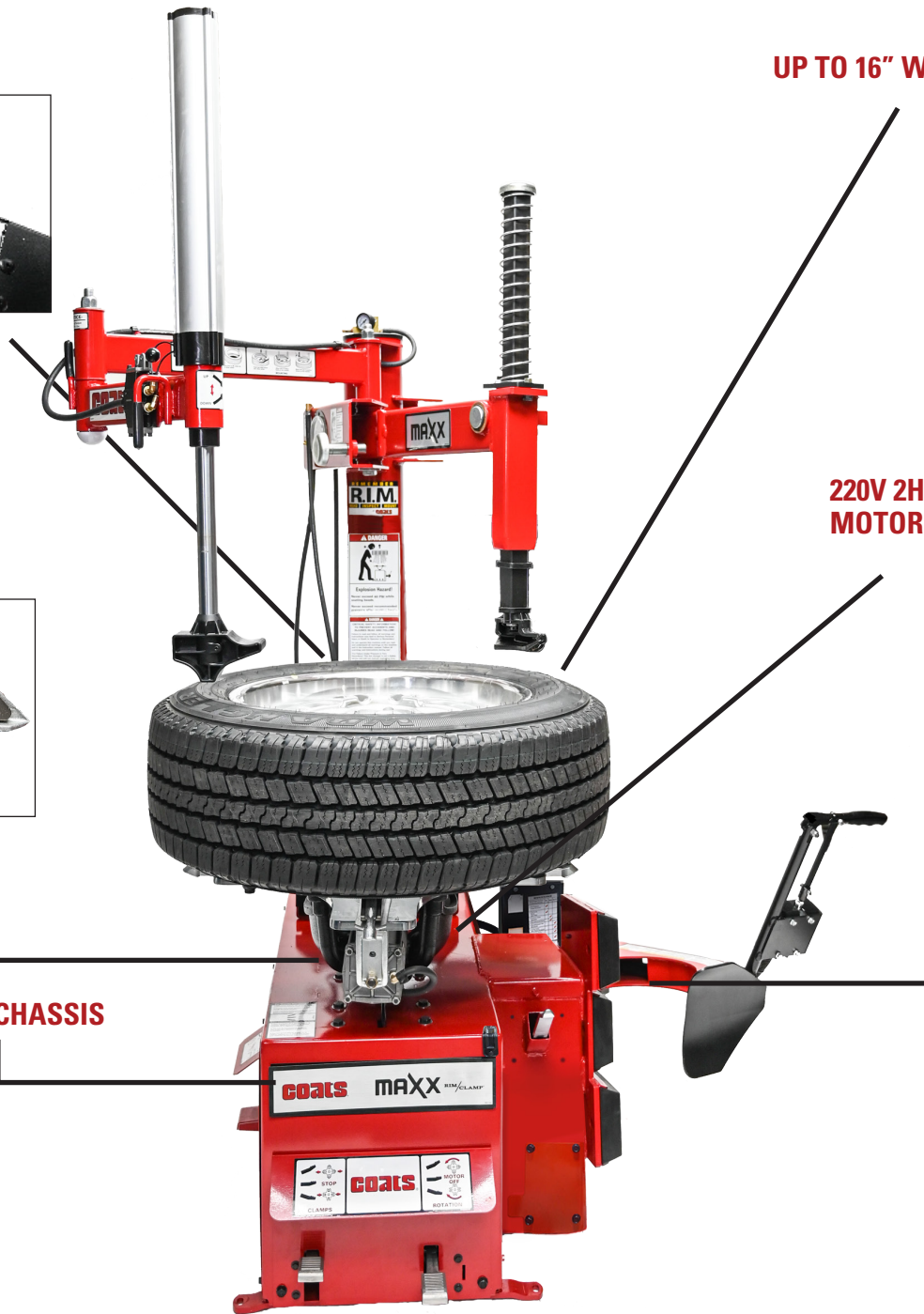

WHO WE ARE

The COATS Company is a leading, global manufacturer and distributor of service equipment and solutions. Based in Nashville, TN, we work with shops and dealerships around the world.

WHAT WE DO

- ✓ Maximize your uptime with our durable & reliable product
- ✓ Improve productivity with the fastest floor to floor times
- ✓ Provide easy to use equipment and solutions to our customers

Drawing on decades of expertise, market perspective, and innovative engineering, Coats keeps you ready for the next industry evolution.

WHY COATS

- ✓ **Legacy-** For over 75 years COATS has been trusted by shops and dealers across the country
- ✓ **Reliability-** Customer and technical service when you need it the most
- ✓ **Profitability-** Our products make your shop or dealership more efficient and profitable

SPECIFICATIONS

Wheel Handled	Alloy, Steel for Car & Light/Medium Truck
Rim Diameter	6-24"
Maximum Tire Diameter	50"
Maximum Rim Width	16"
Bead Loosening Width	Up to 22" Wide
Wheel Clamping System	4 Clamps, Air Cylinder Operated
Bead Seating Air Volume	5.4 Gallons in Tower
Air Drive System	110-175 psi, 15 scfm
Electric Drive System	220V 2 HP Electric, 110V Electric Motor
220V Electric Requirements	220V, 10amps, 1PH, NEMA L6-20
Footprint	74" w x 86" h x 44" d
Ship Weight	805 lbs. Low center of gravity for stability
Warranty	3 Year Parts, 6 Months Labor
Part Numbers	Elec 220V: 800MAXX70220 Elec 220V 2 Speed: 800MAXX702SPD Elec 110V: 800MAXX70 Air: 800MAXX70A

*Max air motor HP dependent on shop air pressure

EQUIPMENT FOOTPRINT

Elec. 220V w/Lift: 800MAXX70220L
Elec. 220V, 2-spd w/Lift: 800MAXX702SPDL
Elec. 110V w/Lift: 800MAXX70L
Air w/Lift: 800MAXX70AL

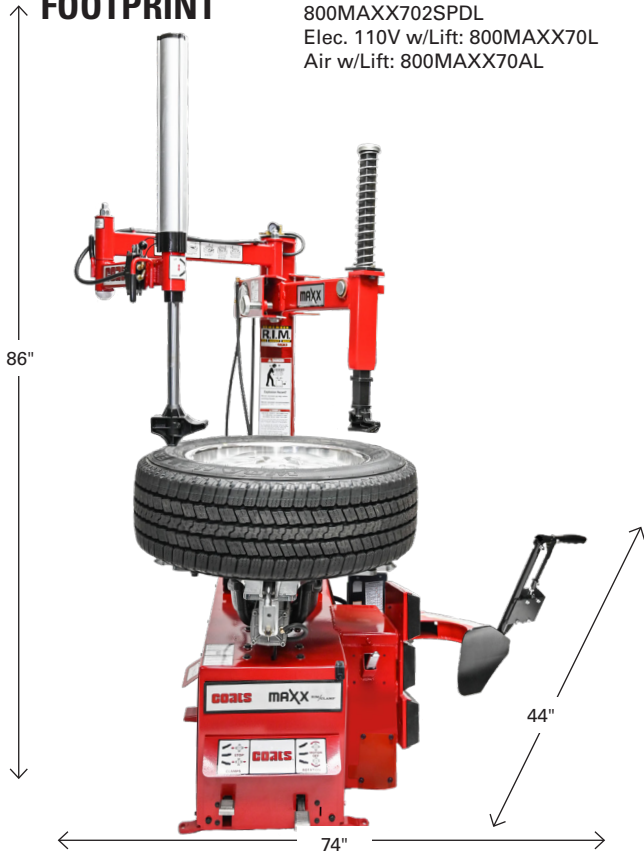

INCLUDED ACCESSORIES

Part Number	Description
8183061	Polymer Duckhead
8182788	Steel Duckhead® Mount/Demount Tool
8184926	Steel Clamps

RECOMMENDED OPTIONAL ACCESSORIES



GRIP-MAX 2.0 @ 24" CLAMPS
(PN 85612106)

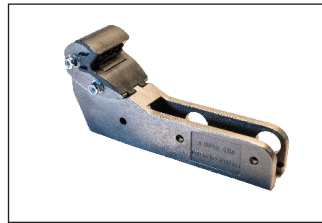

GRIPMAX @ 30" EXTENDED CLAMPS - 4
(PN 85607986)

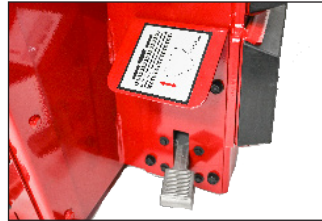

FOOT OPERATED BEAD LOOSENER KIT
(PN 85611558-01)
CONTACT YOUR COATS SERVICE REP FOR PRICING AND INSTALLATION



ROBO-ROLLER® BEAD ROLLER ARM KIT
(PN 85611867-01)
CONTACT YOUR COATS SERVICE REP FOR PRICING AND INSTALLATION

Visit our website for videos, interactive content, and virtual training

coats
SERVICE NETWORK
Servicing Coats, AMMCO and BaseLine products

SALES: 1-855-876-3864
SERVICE: (800) 688-6359
TEXT FOR SERVICE: (615) 392-3193
Please provide: Serial #, Shop Name, Full Address

- Free Setup & Training
- Preventative Maintenance
- Technical Support Team

