

# COATS®

**10,000 LB. (4,536 KG)**

## LOW-RISE LIFT

**Model: 4TPD10SSR1 (220V)  
4TPD10SSR4 (110V)**

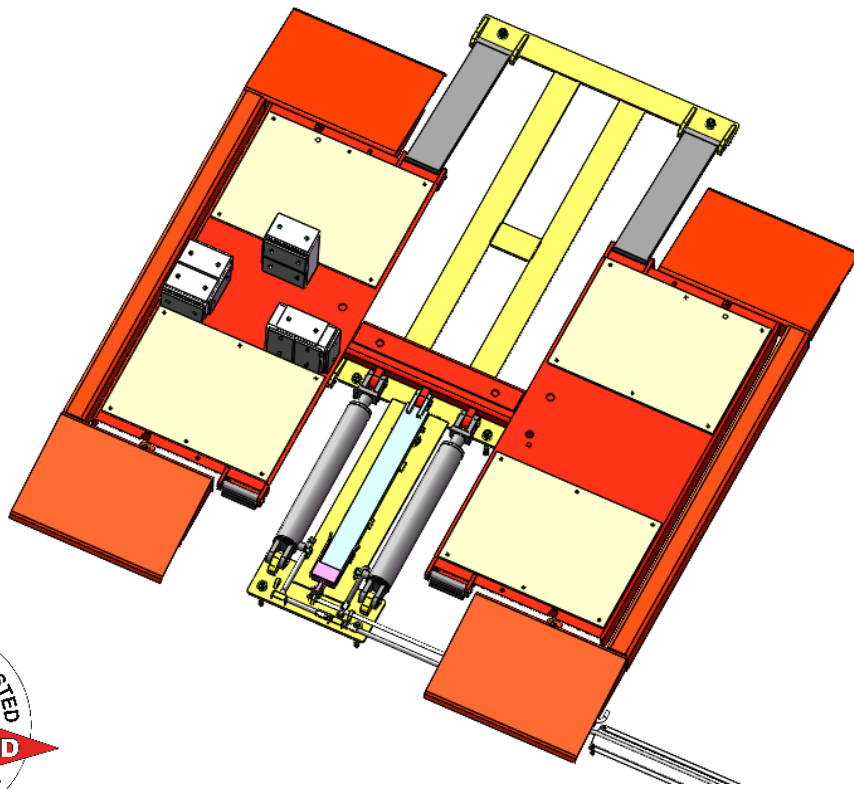

**INSTALLATION  
& OPERATION  
MANUAL  
SERVICE PARTS  
MANUAL**

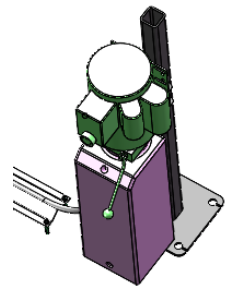

TOTAL AUTOMOTIVE LIFTING SOLUTIONS INC.  
2300 SPEER ROAD, OAKVILLE, ON L6L 2X8  
(877) 799-LIFT (5438) [www.tslifts.com](http://www.tslifts.com)

10/2024

**READ** the manual thoroughly before installing, operating, servicing or maintaining the lift.

**SAVE** this manual and all instructions.



Your new lift will provide years of dependable service if installed, operated and maintained properly. Follow all safety, installation, operation, and maintenance instructions in this manual before installing and operating the lift. In addition, follow all safety and other information included on and with the lift before operating the lift. Keep this manual in a secure place for future reference, training and service part identification.

## **Table of Contents**

IMPORTANT SAFETY INSTRUCTIONS .....	4
SAFETY INSTRUCTION AND INFORMATION DECAL KIT .....	5
OWNER/EMPLOYER RESPONSIBILITY .....	6
INSTALLATION INSTRUCTIONS .....	7
GENERAL REQUIREMENTS AND LIFT SPECIFICATIONS .....	9
RECOMMENDED BAY DIMENSSIONS.....	10
OPERATION MANUAL .....	17
MAINTENANCE INSTRUCTIONS.....	20
TROUBLE SHOOTING .....	21
LIFT LOCKOUT/TAGOUT PROCEDURE.....	22
PARTS BREAKDOWN .....	24
HEIGHT ADAPTER ASSEMBLY (47102700).....	26

**IMPORTANT:** It is the shop owner's responsibility to provide a satisfactory installation area for the lift. Lift should only be installed on level concrete floors with no more than 3° of slope and with a minimum of 4 inches (102mm) and 3000 psi (20.7MPa) concrete that has been aged a minimum of 30 days. Please consult a qualified individual if any doubt exists concerning proper installation and subsequent safe operation of the lift. Do not install the lift on asphalt or outdoors. Failure to comply with these minimum standards could result in personal injury or death.

Prior to installation, it is the shop owner's responsibility to provide constant electrical power in the correct voltage, phase, etc., and all wiring for electrical hook-up of the lift. The shop owner must insure that the electrical installation conforms to local building and safety codes. Where required, the shop owner will provide an electrical isolation switch located in close proximity to the lift. This switch will have an emergency stop capability and isolate electrical power from the lift for servicing requirements.

Hydraulic oil cannot be shipped with the lift and will be supplied by either the shop owner or the installer. ISO 32 hydraulic oil (10W non detergent hydraulic oil) must be used to fill the reservoir tank before operating the lift.

**It is the shop owner's responsibility to train all operators in lift operation and lift safety.**

# **IMPORTANT SAFETY INSTRUCTIONS**

When using your garage equipment, basic safety precautions should always be followed, including the following:

1. Read and follow all safety instructions and decals included with the lift. Read and follow all safety instructions in this manual. Read and follow the ALI/SM 22-1 or more current edition (Lifting It Right) and ALI/ST-17 or more current edition (Safety Tips) manual (included with the lift). Always use the "Vehicle Lifting Points" reference guide when lifting a vehicle. Insure all materials stay up to date >>> [www.autolift.org/](http://www.autolift.org/).
2. Only trained and authorized personnel should position a vehicle and operate the lift. Do not allow customers or bystanders to operate the lift or be in the lift area.
3. Inspect the lift daily. Do not operate if potential problems have been identified or lift malfunctions. Do not operate if lift has damaged or broken components. Never walk or work under the lift unless all safety locks are completely engaged.
4. Never overload the lift. The rated capacity decal is located on the powerpack column. The hydraulic system on this lift is not designed to be a load holding device. Mechanical safety locks must be engaged before proceeding under the lift for vehicle servicing or lift maintenance. Never override operating controls. This is unsafe and will void the warranty.
5. Before driving a vehicle onto the lift, insure that both slip plates and turn plates have all lock mechanisms securely in place. Also insure that the lift and lift area is clear of all debris and that all oil and grease has been cleaned from runway surfaces.
6. Before raising or lowering the lift, always totally secure the vehicle with wheel chocks.
7. When using a jack(s) to raise a vehicle, position jack lifting pads to contact vehicle manufacturers recommended lifting points. Raise jack slowly until all pads contact the vehicle. Confirm that the vehicle is stable on the jack(s) before raising to desired working height.
8. Some pickup trucks may require optional truck adapters to clear running boards and other installed accessories. Special care must be exercised with pick-up trucks to insure safe lifting. Always use vehicle manufacturers lifting points.
9. Important: Removal or installation of heavier parts can change the vehicle's center of gravity on the jack(s) resulting in a critical load shift. The vehicle may then be unstable. Plan ahead for this possibility to insure continued safety and refer to the vehicle manufacturer's service manual for recommended procedures.
10. Always keep the lift area free of obstructions and debris. Grease and oil spills should be cleaned up immediately.
11. Never raise a vehicle on the lift with passengers inside. Before lowering, check the lift and lift area and remove all obstructions. Before removing vehicle from the lift or lift area, confirm an unobstructed exit.
12. DO NOT PERFORM ANY MAINTENANCE OR INSTALLATION OF ANY COMPONENTS WITH OUT FIRST ENSURING THAT ELECTRICAL POWER HAS BEEN DISCONNECTED AT THE SOURCE OR PANEL AND CANNOT BE RE-ENERGIZED UNTIL ALL MAINTENANCE AND/OR INSTALLATION PROCEDURES ARE COMPLETED (ANSI 244.1).

## **SAVE THESE INSTRUCTIONS**

# SAFETY INSTRUCTION AND INFORMATION DECAL KIT

**SAFETY WARNING LABELS  
FOR HINGED FRAME ENGAGING LIFTS**

**Lift Owner/User Responsibilities:**

A. This Safety Warning placard **SHALL** be displayed in a conspicuous location in the lift area.  
 B. Use one of the mounting arrangements illustrated on back of this placard.  
 C. These Safety Warning labels supplement other documents supplied with the lift.  
 D. Be certain all lift operators read and understand these labels, operating instructions and other safety related information supplied with the lift.

 <b>WARNING</b> Position vehicle with center of gravity midway between adapters.	 <b>WARNING</b> Remain clear of lift when raising or lowering vehicle.	 <b>WARNING</b> Keep feet clear of lift while lowering.	 <b>NOTICE</b> Read operating and safety manuals before using lift.	 <b>NOTICE</b> Proper maintenance and inspection is necessary for safe operation.	 <b>NOTICE</b> Do not operate a damaged lift.
 <b>WARNING</b> Clear area if vehicle is in danger of falling.	 <b>WARNING</b> Avoid excessive rocking of vehicle while on lift.	 <b>WARNING</b> Keep clear of pinch points when lift is moving.	 <b>CAUTION</b> Lift to be used by trained operator only.	 <b>CAUTION</b> Always use safety stands when removing or installing heavy components.	 Power Unit: Apply labels near lift controls.
<a href="http://www.autolift.org">www.autolift.org</a>			 <b>CAUTION</b> Authorized personnel only in lift area.	 <b>CAUTION</b> Use vehicle manufacturer's lift points.	 Lift Control Console: Apply labels in an accessible location.

The messages and pictographs shown are generic in nature and are meant to generally represent hazards common to all automotive lifts regardless of specific style.  
 Funding for the development and validation of these labels was provided by the Automotive Lift Institute, PO Box 85 Cortland, NY 13045.  
 Replacement label sets may be obtained from the original lift manufacturer and ALI's member companies.  
 They are protected by copyright.  
 www.autolift.org  
 © 2015 by ALI, Inc. ALIWL1300

**Review all safety information daily with all lift operators**

**LIFT SAFETY and LIFT MAINTENANCE MUST BE PART OF YOUR DAILY ROUTINE**

**IMPORTANT:**

**Insure Safety Instruction Decals and Hang Card are affixed to the lift immediately following installation and before the lift is used**

## **OWNER/EMPLOYER RESPONSIBILITY**

**The Owner/Employer shall** ensure that all lift operators are qualified and that they are trained in the safe use and operation of the lift using the manufacturer's operating instructions; ALI/SM 93-1, ALI SAFETY Tips card; ANSI/ALI ALOIM: 2020 or a more current edition, American National Standard for Automotive Lifts-Safety Requirements for Operation, Inspection and Maintenance; ALI/WL Series, ALI Uniform Warning Label Decals/Placards; and in the case of frame engaging lifts, ALI/LP-GUIDE, Vehicle Lifting Points/Quick Reference Guide for Frame Engaging Lifts.

**The Owner/Employer shall** establish procedures to periodically inspect the lift in accordance with the lift manufacturer's instructions and ANSI/ALI ALOIM: 2020 or a more current edition, American National Standard for Automotive Lifts-Safety Requirements for Operation, Inspection and Maintenance. The owner/employer shall also ensure that lift inspectors are qualified and that they are adequately trained in the inspection of the lift.

**The Owner/Employer shall** establish procedures to periodically maintain the lift in accordance with the lift manufacturer's instructions and ANSI/ALI ALOIM: 2020 or a more current edition, American National Standard for Automotive Lifts-Safety Requirements for Operation, Inspection and Maintenance. The owner/employer shall also ensure that lift maintenance personnel are **qualified** and that they **are adequately trained** by factory in the maintenance of the lift.

**The Owner/Employer shall** maintain the periodic inspection and maintenance records recommended by the manufacturer or ANSI/ALI ALOIM: 2020 or a more current edition, American National Standard for Automotive Lifts-Safety Requirements for Operation, Inspection and Maintenance.

**The Owner/Employer shall** display the lift manufacturer's operating instructions; ALI/SM 93-1, ALI Lifting it Right safety manual; ALI/ST-90 ALI Safety Tips card; ANSI/ALI ALOIM: 2020 or a more current edition, American National Standard for Automotive Lifts-Safety Requirements for Operation, Inspection and Maintenance; and in the case of frame engaging lifts, ALI/LP-GUIDE, Vehicle Lifting Points/Quick Reference Guide for Frame Engaging Lifts in a conspicuous location in the lift area convenient to the operator.

**The Owner/Employer shall** provide necessary lockout/tagout means for energy sources per ANSI Z244.1-1982 (R1993), Safety Requirements for the Lockout/Tagout of Energy Sources, before beginning any lift repairs.

**The Owner/Employer shall** not modify the lift in any manner without prior written consent of the manufacturer.

# **INSTALLATION INSTRUCTIONS**

## **BEFORE YOU BEGIN**

Insure the lift installation complies with ANSI/ALI/ALIS: 2022 or more current edition, Safety Requirements for Installation and Service of Automotive Lifts.

### **Safety Precautions and Decals**

Your safety, as well as the safety of others, is paramount. Please carefully review and comprehend all safety notices and indications provided in this manual.

READ ENTIRE MANUAL BEFORE ASSEMBLING, INSTALLING, OPERATING, OR SERVICING THIS EQUIPMENT.

REGULAR MAINTENANCE AND INSPECTION ARE CRUCIAL FOR ENSURING SAFE OPERATION.

Under no circumstances should you operate a lift that is damaged or compromised.

The lift should display safety decals akin to those depicted here when properly installed. Ensure that all safety decals are affixed correctly onto the lift. Make sure that all authorized operators are aware of the location of these decals and fully grasp their significance. Promptly replace any worn, faded, or damaged decals.

**NOTICE** Do not attempt to elevate a vehicle using the lift until it has been installed and adjusted correctly, as outlined in this manual.

All lift components are packaged together in one module held together by steel frames.

Optional accessories are packaged separately.

### **When the lift arrives on site:**

- ✓ If possible have lift unloaded in the installation area and on two 4"x4"x24" Wooden Blocks (required for unpacking)
- ✓ Check for freight damage and report immediately to shipping company who delivered the lift
- ✓ Check for missing parts and report immediately to the factory 1-877-799-LIFT (5438) or (905)847-1198

### **Main Components include:**

- ✓ Lift Assembly – 1 pcs
- ✓ Approach Ramps – 2pcs
- ✓ Hydraulic Hose - 3 pcs.
- ✓ Accessory and Hardware Box
- ✓ Powerpack – 1 pc

**Document Folder includes:**

- ✓ WL-300 Safety Information Label Kit – 1pc
- ✓ ALI - "Lifting It Right "Manual – 1pc
- ✓ ALI - "Vehicle Manufacturer's Lifting Point Guide" – 1pc
- ✓ Automotive Lift Safety Tips Hang Card – 1pc
- ✓ Automotive Lift, Operation, Inspection and Maintenance Manual – 1pc
- ✓ Owner's Manual – 1pc

**Hardware Box includes:**

- ✓ Fittings, bolts, washers, nuts, anchor bolts, etc.

**Tools Required for Installation**

1. Concrete hammer drill.
2. 5/8-inch Concrete drill.
3. Wrenches: 7/16, 1/2, 9/16, 5/8, 11/16, 15/16, 1 1/8 inch
4. Ratchet drive with the following sockets: 7/16, 1/2, 9/16, 5/8, 1 1/8 inch
5. Hammer
6. Funnel
7. Torque wrench: 80 foot pounds
8. Adjustable wrenches: 8 and 12 inches

# GENERAL REQUIREMENTS AND LIFT SPECIFICATIONS

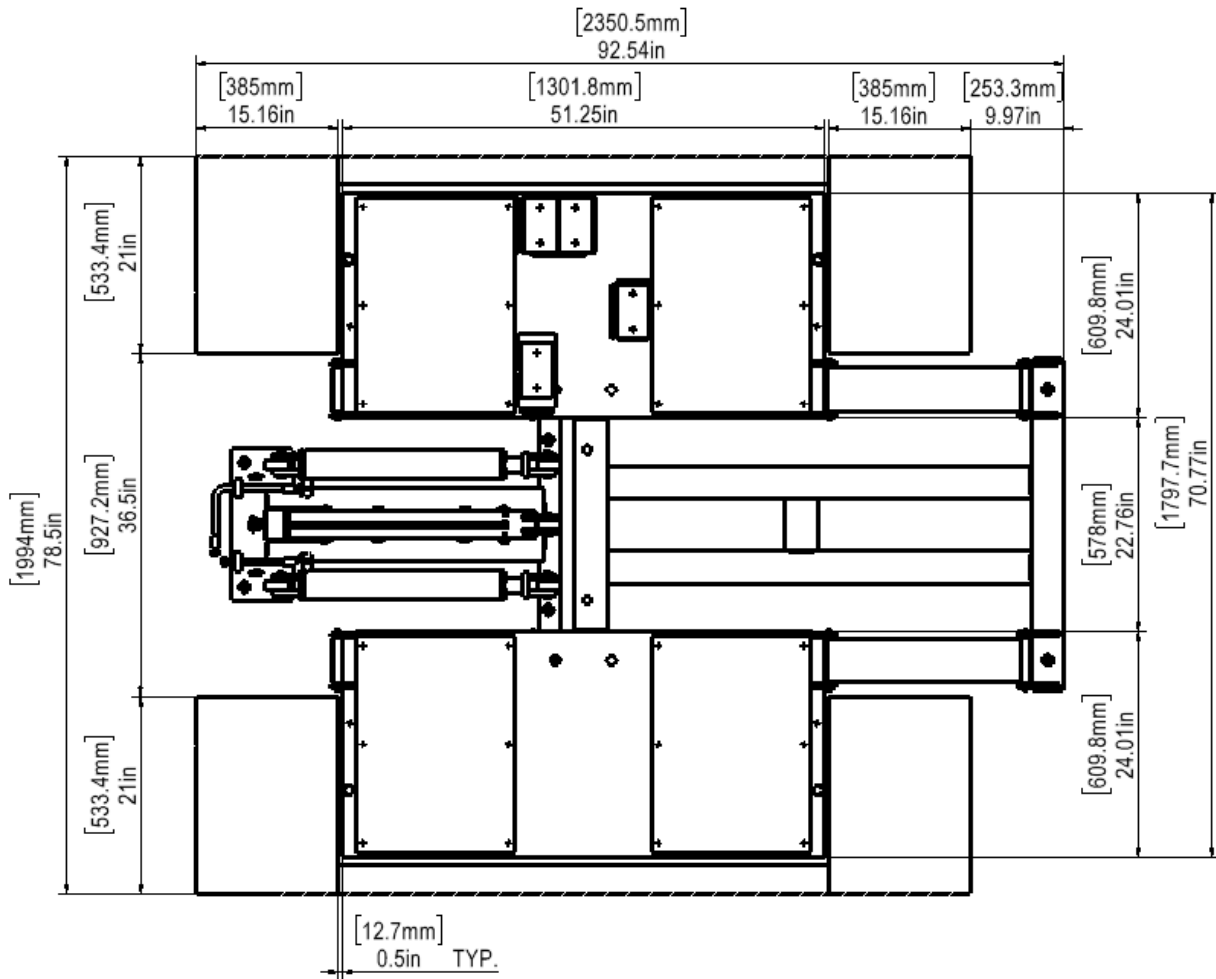

Fig. 1

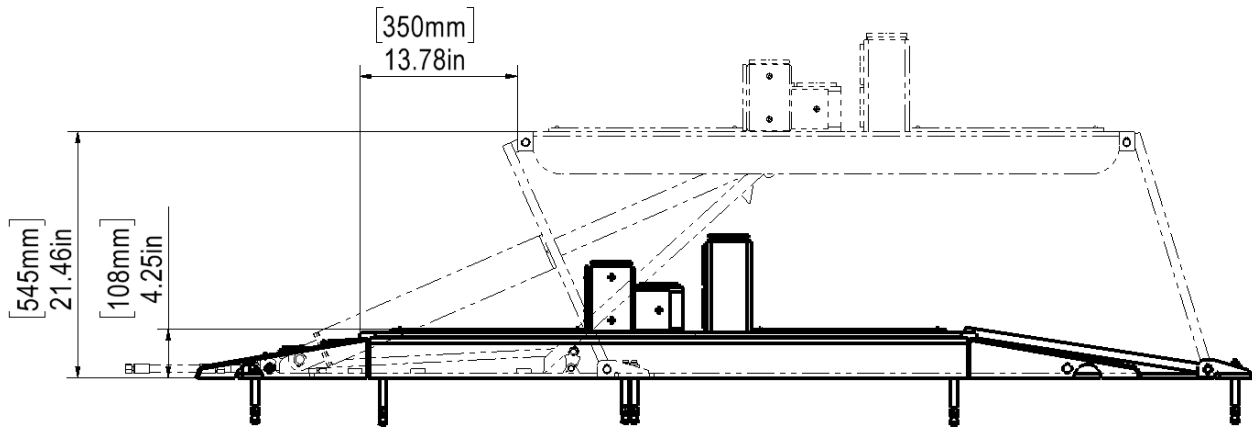

Fig. 2

**Motor:** 2HP, 230VAC 1PH, 60Hz, **Max. Operating Pressure (full load):** 1,600psi

**or Motor:** 1HP, 110VAC 1PH, 60Hz, **Max. Operating Pressure (full load):** 1,465psi

**Lift should only be installed on level concrete floors with a minimum of 4 inches and 3000 psi (20.7MPa) concrete that has been aged a minimum of 30 days. A qualified person should be consulted to address seismic loads and other local or state requirements.**

**This lift is designed for INDOOR use only, outdoor installation is prohibited.**

Ongoing design modifications and quality improvements may change specifications listed in this manual without notice

## RECOMMENDED BAY DIMENSIONS

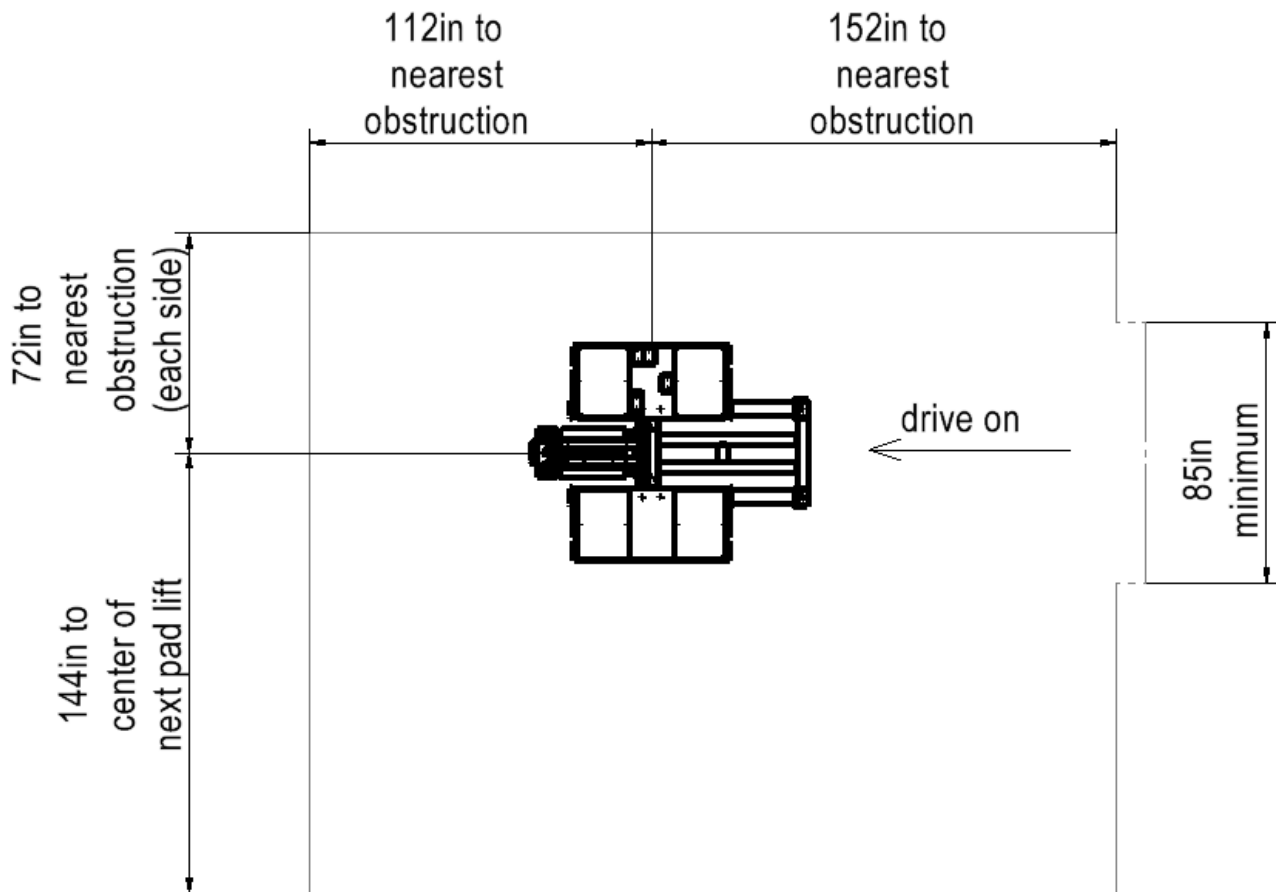

Fig. 3

### 1. Selecting the Lift Location:

Always consult the building plans provided by the architect, if available. The lift should be situated on a relatively level floor within a space that allows sufficient working area around the vehicle (refer to Fig. 3).

**NOTICE**

**INSTALLER'S NOTE:** The lift can be installed with the cylinder end oriented towards either the front or rear of the bay. Pay close attention to lift clearance requirements; clearance should be calculated based on the full raised height of the lift plus the height of the tallest vehicle you intend to service. DO NOT install the lift on asphalt or similar unstable surfaces. At full rise, the lift moves the vehicle 13.78 inches (350mm) (refer to Fig. 2).

## 2. Removal of Shipping Materials:

Remove any shipping bands and wooden skids from the lift before proceeding.

## 3. Anchoring:

A. The anchor bolts must be placed at least 6 inches (152mm) away from any edge or seam in the concrete.

B. The concrete should possess a compression strength of at least 3,000 PSI (20MPa) and a minimum thickness of 4 inches (102mm) to achieve a minimum anchor embedment of 3-1/4 inches (83mm). If using the standard supplied 5/8 inch x 5-1/2 inch long anchors, and if the top of the anchor exceeds 2-1/4 inches above the floor grade, there is insufficient embedment.

C. Utilize a concrete hammer drill with a 5/8-inch concrete tip. The tip diameter should adhere to ANSI Standard B94.12-1977.

D. Drill (8) 5/8 inch (or 16mm) diameter holes in the concrete floor, using the holes in the base plate as a guide (refer to Fig. 4). Drill the holes through the floor or to a minimum depth of 5 inches. If possible, drill completely through the floor.

E. Remove dust from the holes using a vacuum. This enhances the holding power of the anchor bolts.

F. Insert the assembled anchor bolt into the hole.

G. Tighten the bolt securely, and torque it to 80 ft-lbs.

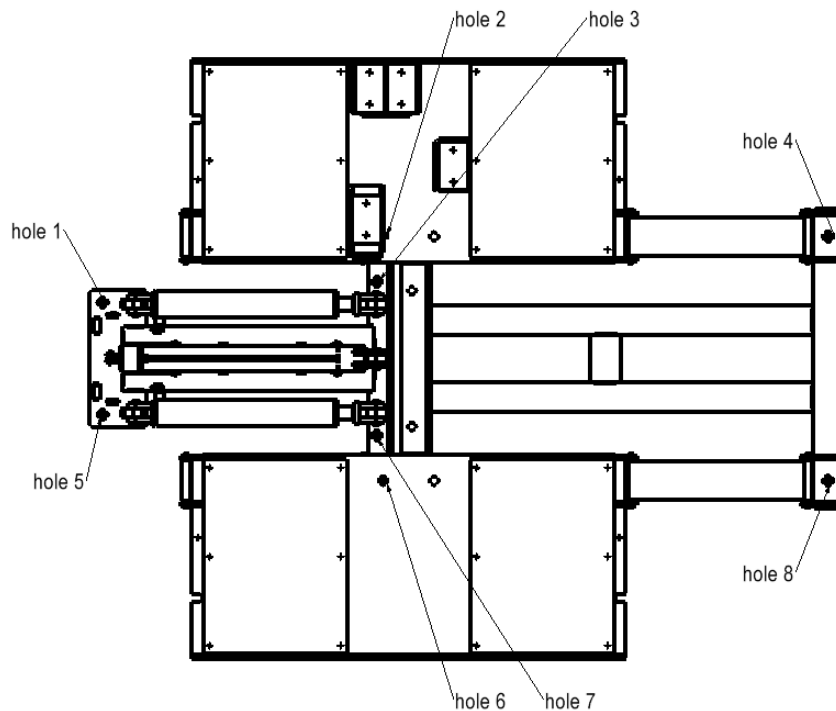

Fig. 4

## NOTICE

**IMPORTANT INSTALLATION NOTES:** Ensure that the frame remains free from twisting, bending, or any form of misalignment caused by unlevel floors or improper anchoring. Misalignment can lead to damage to the lift. The maximum allowable out-of-level at anchors is: 1/4 inch (6mm) side to side; 1/2 inch (13mm) front to rear. If the floor exhibits a crown of more than 1/4 inch (6mm) between front to rear anchors, shim at the anchors. The top structure should be parallel to the bases within 1/4 inch (6mm). Utilize the shim kit FJ2426 or grout to level the floor.

### 4. Install Power Unit And Mounting Post:

A. Consult the client for the placement of the power unit mounting post. Use the stand as a template to mark the location of the (4) floor anchor holes. Note that the post requires four 1/2 inch diameter anchors, which differs from that of the lift. Utilize a 1/2 inch concrete drill bit to drill and install anchors for the post.

B. Attach four 5/16 inch x 1 inch (M8x20) bolts to the four holes in the mounting bracket with 5/16 inch (M8) plain washers. Attach the power unit to these bolts and secure it with M8 nylon insert nuts.

C. Adding fluid: Remove the fill-cap (red) from the tank and fill it with 2 Gallon hydraulic oil meeting ISO 32 specifications. Replace the fill-cap with the vent cap (black).

### 5. Electrical Connections:

A. The power unit comes fully wired and ready to plug into a 115-volt, single-phase, 60 Hz circuit. A six-foot, 3-wire power cord with a grounding plug is provided.

## NOTICE

Utilize a separate circuit with a time delay fuse or circuit breaker for each power unit. For single-phase 120V use, a 20 amp. fuse is recommended. Ensure that wiring and power unit locations comply with local electrical codes.

B. Optional 208V-230V operation: If operating on 208V-230V, have a certified electrician run a 230V single-phase 60Hz power supply to the 2 HP motor (refer to Fig. 5). Size the wire for a 20 amp circuit as per Motor Operating Data table.

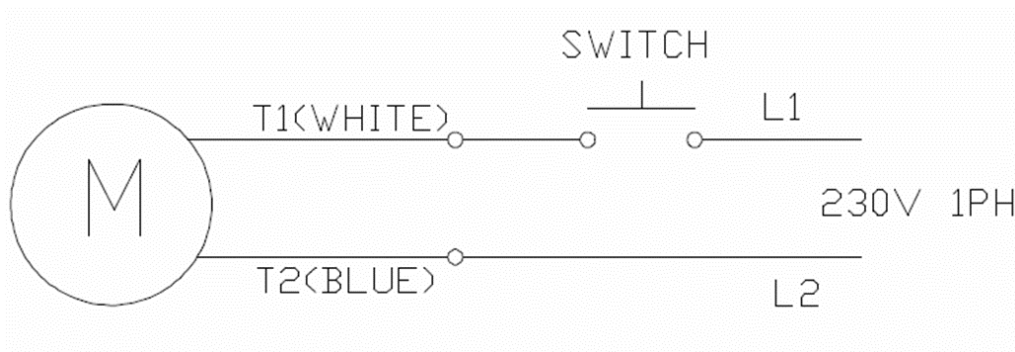

Fig. 5

### 6. Hydraulic System Setup and Hose Routing:

- A. When tightening connections with flared (JIC) fittings, adhere to the following tightening instructions to prevent cracked fittings or leaks:
- B. Connect the long hydraulic hose to the branch on the JIC tee fitting (refer to Fig. 6 A).
- C. Connect the short hydraulic hoses to the elbows on the cylinders (refer to Fig. 6 B). These connections should be hand-tight only. Feed the free ends of the hoses through the hose guides (refer to Fig. 6 C&D).
- D. Connect the short hoses to the runs on the JIC tee fitting (refer to Fig. 6 E).
- E. With the lift at its lowest position, loosen the connections between the hoses and fittings attached to the cylinders. Do not loosen the connections between the fittings and the cylinders themselves.
- F. Operate the power unit until fluid appears at the cylinder ports. Then, tighten the hose connections.
- G. Add fluid to the system as previously described.

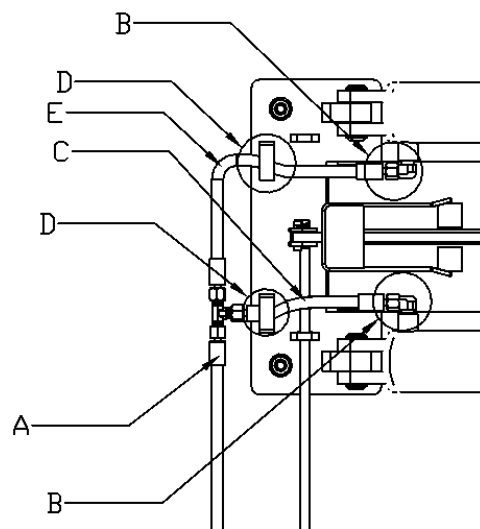

Fig. 6

**NOTICE** To avoid damage to the hose, never run the hose under the lift or in the path of the automobile tires.

### 7. Positioning of Ramps:

A. The ramps must be positioned as depicted in Fig. 7, ensuring a minimum clearance of 1/2 inch (13mm) between the ramp and the front edge of the pad opposite the cylinders, and a clearance of 7/8 inch (22mm) between the outside surfaces of the pad and the inside surface of the ramps. **DO NOT DRILL ANCHOR HOLES AT THIS TIME!**

B. Elevate and lower the lift through one complete cycle to verify that there is sufficient clearance between the ramps and the pad.

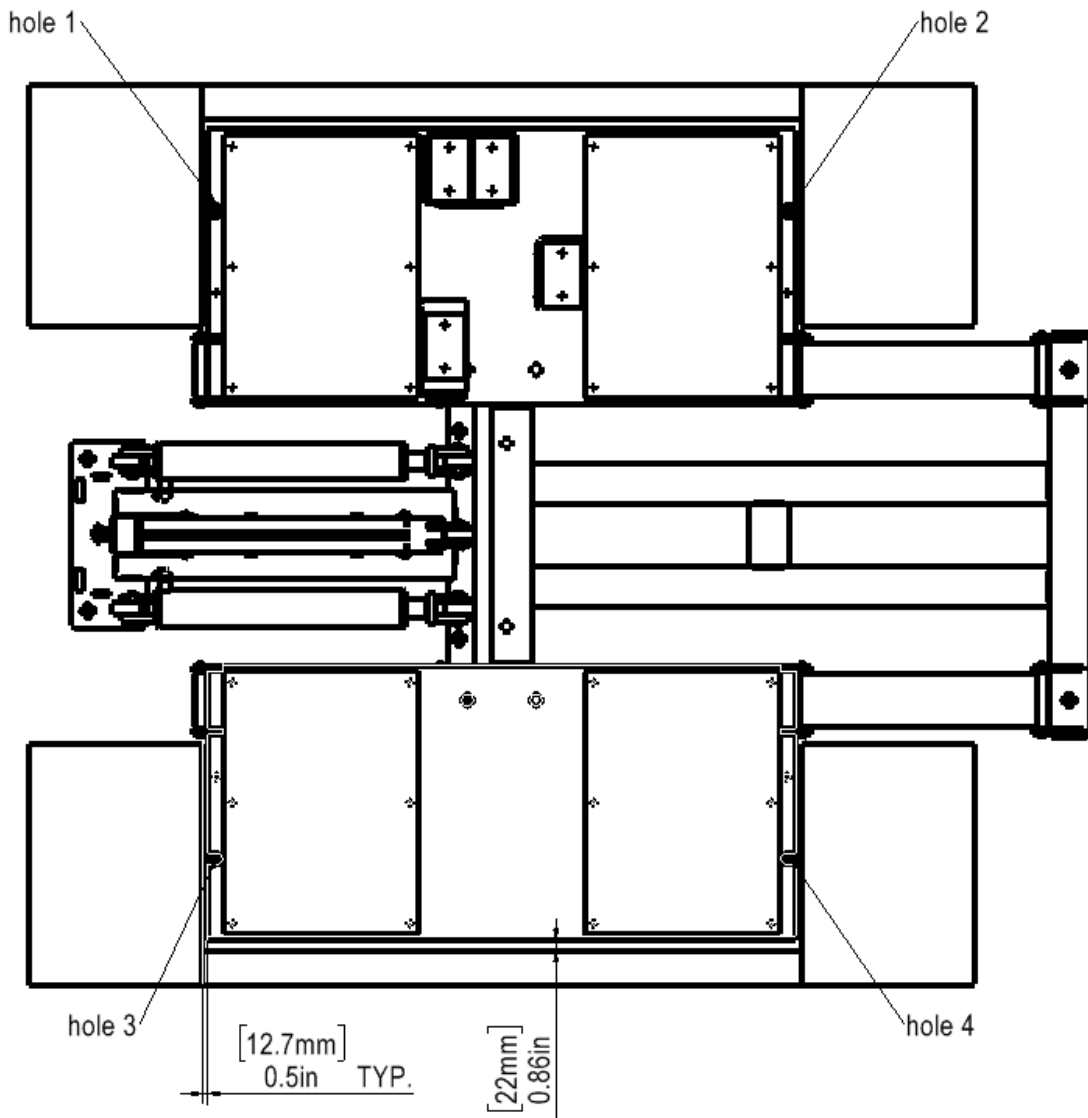

Fig. 7

### 8. Installing the Lock Release Handle:

- A. Insert the latch release handle through the access hole in the ramp nearest the power unit.
- B. Insert the keyed end of the handle through the keyway in the latch release weldment as shown in Fig. 8.
- C. Install the roll pin into the end of the handle as shown in Fig. 8.

Note: Lift is shipped with two (2) latch release handles, the long one is for surface mount installation, the short one is for flush mount installation. Installer must choose one (1) based on customer requirement.

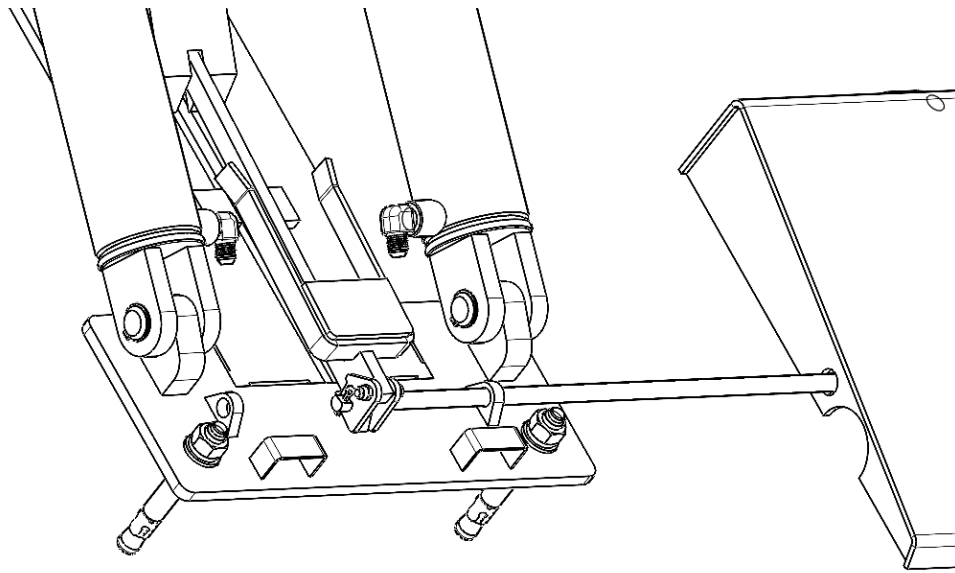

Fig. 8

**9. Anchoring the Ramps:**

Utilize a 5/8-inch (or 16mm) concrete drill bit to drill holes and install (4) anchors to secure the ramps (refer to Fig. 7).

**10. Installing Hose Guard:**

A. Position the hose guard over the hose. Note: The hose guard is intended to prevent damage to the hose when driven over and to minimize tripping hazards.

B. Drill 3/16 inch anchor holes and install tapcon screws.

**11. Installing Handle Protector:**

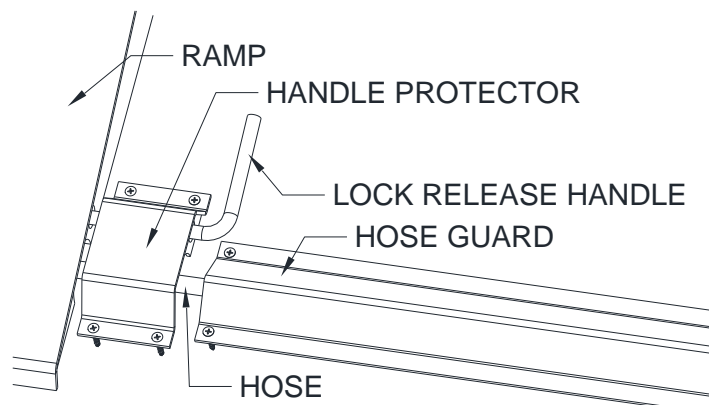

Fig. 8.1

A. Position the handle protector over the lock release handle and the hose.

B. Drill 3/16 inch anchor holes and install tapcon screws.

**12. Final Adjustments:**

- A. If any issues arise, refrain from proceeding with subsequent steps. Instead, address the problem before continuing by consulting the Troubleshooting section of the Owner's Manual.
- B. Elevate the lift empty to the top of its travel and lower it to the floor three (3) times to expel any remaining air from the hydraulic system and to confirm that the power unit does not stall at relief pressure.
- C. Position a vehicle on the lift, raise it to full height, and then lower it onto the safety latches. Lower the vehicle to the floor.
- D. After cycling the lift ten times with a vehicle on it, recheck the tightness of the lift anchors, tightening them to 80 ft-lbs.

# OPERATION MANUAL

## **SAFETY INSTRUCTIONS:**

. **Please refer to ANSI/ALI ALOIM: 2020 or a more current edition for operation of the lift.**

- **Daily Inspection:** Regularly inspect your lift. Refrain from operating it if it malfunctions or if any parts are broken or damaged. Only employ qualified lift service personnel and use genuine TLS parts for repairs.
- **Employee Training:** Thoroughly train all personnel in the proper use and maintenance of the lift, following the manufacturer's instructions, as well as the "Lifting It Right" and "Safety Tips" guides provided with the lift.
- **Authorized Personnel:** Ensure that only trained and authorized individuals position vehicles or operate the lift. Unauthorized persons should not be permitted in the shop area while the lift is in use.
- **Safety Precautions:** Prohibit anyone from being on the lift or inside the vehicle while it is being raised or lowered. Keep the area around the lift free of tools, debris, grease, and oil.
- **Weight Capacity:** Never overload the lift. Its capacity is 10,000 lbs., with 2500 lbs. per pad.
- **Positioning and Operation:** Before driving a vehicle into the lift bay, ensure that the lift is fully lowered. Carefully load the vehicle onto the lift, positioning lift adapters to make contact at the vehicle manufacturer's recommended lift points. Do not go under the vehicle if locking latches are not engaged.
- **Control Precautions:** Do not block open or override self-closing lift controls. Stay clear of the lift when raising or lowering a vehicle.
- **Shutdown Protocol:** Always lower the lift completely and disconnect the power source before disconnecting hydraulic lines.
- **Cautionary Measures:** Avoid excessive rocking of the vehicle while on the lift. Clear the area if the vehicle is at risk of falling. Lower the lift entirely before removing the vehicle from the lift area.
- **Locking Latch Reset:** Release locking latches before attempting to lower the lift. The locking leg latch will reset automatically only when the lift is fully lowered. If the lift is stopped before reaching the fully lowered position during the lowering process, manually reset the locking leg latch by rotating the latch release handle.

**Note:** Vehicle manufacturer's recommended pick-up points must be engageable by lift structure or adapter blocks. The vehicle frame must be strong enough to support its weight and should not be weakened by modification or corrosion. Avoid raising limousines, specialty, or other modified vehicles.

### **Before lifting the vehicle, ensure the following:**

A. Verify that the pads are securely in contact with the frame or support structure at the vehicle manufacturer's recommended pick-up points.

B. Certain vehicles may require additional clearance under the carriage or exhaust system to avoid contacting the pad support. Utilize auxiliary adapters located at the vehicle manufacturer's recommended pick-up points, if necessary.

**Note:** Allow (2) seconds between motor starts to prevent motor burnout.

**Procedure to Raise the Lift:**

To raise the lift, follow these steps:

- A. Push the Raise Switch (A) on the power unit (refer to Fig. 9).
- B. Stop before making contact with the vehicle. Ensure that the wheels and/or mud flaps clear the pad end ramps.
- C. Raise the vehicle until the tires clear the floor.
- D. Stop and check the pads for secure contact at the vehicle manufacturer's recommended lift points.
- E. Continue to raise the lift to the desired height only if the vehicle is securely positioned on the lift.
- F. Repeat the complete spotting, loading, and raising procedures if required.
- H. Actuate the Lowering Handle (B), as depicted in Fig. 9, to lower the lift onto the locking latches.

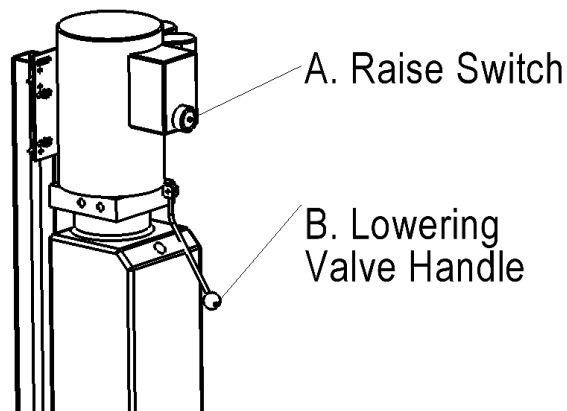

Fig. 9

**NOTICE**

DO NOT go under vehicle if locking latches are not engaged.

**Procedure to Lower the Lift:**

- A. Clear the lift area of all tools, bystanders, and other objects.
- B. Raise the lift off the locking latches.
- C. Rotate the Latch Release Handle, as illustrated in Fig. 10.
- D. Push the Lowering Valve Handle (B) to lower the lift, as shown in Fig. 9.

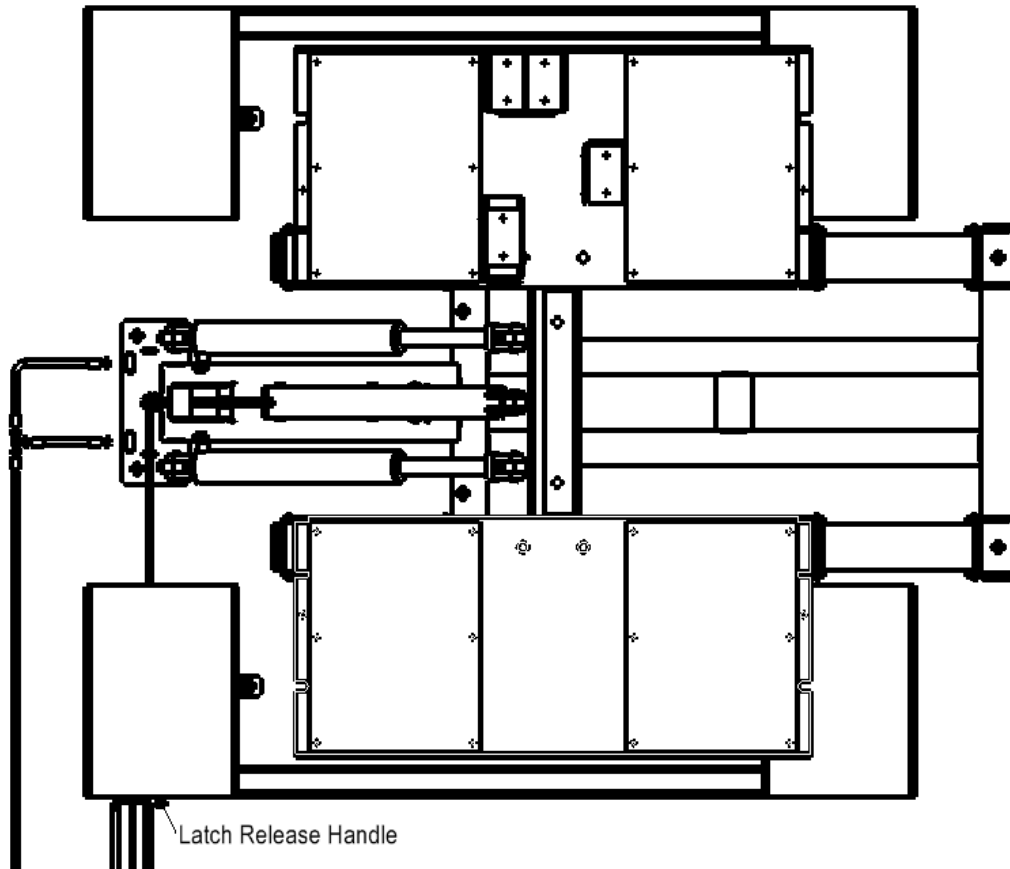

Fig. 10

**Clearance Warning:** Remain clear of the lift when lowering the vehicle.

Remove adapters from under the vehicle. Ensure that the lift is fully lowered before removing the vehicle.

If the lift is not operating properly, do not use it until adjustments or repairs are made by qualified lift service personnel.

# MAINTENANCE INSTRUCTIONS

The maintenance is to be performed by factory trained lift service personnel only.

**Important:** Regularly inspect the hydraulic pressure developed upon the rated capacity, and make sure the pressure doesn't exceed the operating pressure.

**LIFT MAINTENANCE:** The following is a minimum maintenance schedule:

## DAILY:

- ✓ Raise and lower the lift (with no vehicle) at the beginning of each shift to verify the runways are level, safety locks are engaging, and the lift is operating properly.
- ✓ Check all hydraulic fittings and lines for damage and leaks. Check electrical wiring for damage. Check all moving parts for uneven or excessive wear. Repair or replace all damaged, worn, or broken components immediately.
- ✓ Clean all debris from the base frame area
- ✓ Remove oil/grease on runways and rolling jack lift pads.

## WEEKLY:

- ✓ Check hydraulic fluid in reservoir and top up if required.
- ✓ Check lifting cylinders.

## MONTHLY:

- ✓ Check that all anchor bolts are re-torqued to 70 ft-lbs.
- ✓ Clean and lubricate moving parts.

## EVERY YEAR:

- ✓ Have a certified lift technician inspect and certify all aspects of the lift as per "Automotive Lift Operation, Inspection and Maintenance" (ANSI/ALI ALOIM: 2022 or a more current edition) guidelines.

## EVERY TWO YEARS:

- ✓ Change and replace hydraulic oil in cylinders and powerpack reservoir.

## LUBRICATION SPECIFICATIONS:

- ✓ Where grease is required use a multi-purpose lithium grease
- ✓ Where lubricating oil is required use a SAE 30 oil
- ✓ Where hydraulic oil is required use ISO 32 hydraulic oil (10W non detergent)

## **WARNING:**

**FAIL TO LUBRICATE MAY CAUSE PERMENENT DAMAGE TO THE LIFT**

# TROUBLE SHOOTING

<b>Trouble</b>	<b>Cause</b>	<b>Remedy</b>
Electric motor does not run.	<ol style="list-style-type: none"> <li>1. Check fuse or circuit breaker.</li> <li>2. Check for correct voltage to motor.</li> <li>3. Inspect all wiring connections.</li> <li>4. Microswitch burned out.</li> <li>5. Motor windings burned out.</li> </ol>	<ol style="list-style-type: none"> <li>1. Replace blown fuse or reset circuit breaker.</li> <li>2. Supply correct voltage to motor.</li> <li>3. Repair and insulate all connections.</li> <li>4. Replace microswitch.</li> <li>5. Replace motor.</li> </ol>
Electric motor runs but will not raise lift.	<ol style="list-style-type: none"> <li>1. Motor runs in reverse rotation.</li> <li>2. Open lowering valve.</li> <li>3. Pump sucking air.</li> <li>4. Suction stub off pump.</li> <li>5. Low fluid level.</li> </ol>	<ol style="list-style-type: none"> <li>1. Change motor rotation by reversing motor leads.</li> <li>2. Repair or replace lowering valve.</li> <li>3. Tighten all suction line fittings.</li> <li>4. Replace suction stub.</li> <li>5. Fill tank with Dexron III ATF or ISO 32 hydraulic fluid.</li> </ol>
Electric motor runs—raises unloaded lift but will not raise vehicle.	<ol style="list-style-type: none"> <li>1. Motor running on low voltage.</li> <li>2. Trash in lowering valve.</li> <li>3. Overloading lift.</li> <li>4. Improper relief valve adjustment.</li> </ol>	<ol style="list-style-type: none"> <li>1. Supply correct voltage to motor.</li> <li>2. Clean lowering valve.</li> <li>3. Check vehicle weight and/or balance vehicle weight on lifts.</li> <li>4. Replace relief valve cartridge.</li> </ol>
Lift slowly settles down.	<ol style="list-style-type: none"> <li>1. Trash in check valve seat.</li> <li>2. Trash in lowering valve seat.</li> <li>3. External fluid leaks.</li> </ol>	<ol style="list-style-type: none"> <li>1. Clean check valve.</li> <li>2. Clean lowering valve.</li> <li>3. Repair external leaks.</li> </ol>
Slow lifting speed or fluid blowing out fill/breather cap.	<ol style="list-style-type: none"> <li>1. Air mixed with fluid.</li> <li>2. Air mixed with fluid suction.</li> <li>3. Fluid return tube loose.</li> </ol>	<ol style="list-style-type: none"> <li>1. Change fluid to Dexron III ATF or ISO 32 hydraulic fluid.</li> <li>2. Tighten all suction line fittings.</li> <li>3. Reinstall fluid return tube.</li> </ol>
Lift going up unlevel.	<ol style="list-style-type: none"> <li>1. Lift installed on unlevel floor.</li> <li>2. Structure of lift is damaged</li> </ol>	<ol style="list-style-type: none"> <li>1. Shim lift to level base, refer to page 12, step 3 in Installation Instruction.</li> <li>2. Contact lift manufacturer's Customer Service.</li> </ol>
Anchors will not stay tight.	<ol style="list-style-type: none"> <li>1. Concrete floor thickness or holding strength not sufficient.</li> </ol>	<ol style="list-style-type: none"> <li>1. Break out old concrete and repour new pad for lift.</li> </ol>
Lift will not raise off of latches.	<ol style="list-style-type: none"> <li>1. Motor, pump, or cylinder failure.</li> </ol>	<ol style="list-style-type: none"> <li>1. Contact lift manufacturer's Customer Service.</li> </ol>

# LIFT LOCKOUT/TAGOUT PROCEDURE

This procedure establishes the **minimum** requirements for the lockout of energy that could cause injury to personnel by the operation of lifts in need of repair or being serviced. All employees shall comply with this procedure.

The responsibility for assuring that this procedure is followed is binding upon all employees and service personnel from outside service companies (i.e., Authorized Installers, contactors, etc.). All employees shall be instructed in the safety significance of the lockout procedure by the facility owner/manager. Each new or transferred employee along with visiting outside service personnel shall be instructed by the owner/manager (or assigned designee) in the purpose and use of the lockout procedure.

Employees authorized to perform lockout shall ensure that the appropriate energy isolating device (i.e., circuit breaker, fuse, disconnect, etc.) is identified for the lift being locked out. Other such devices for other equipment may be located in close proximity of the appropriate energy isolating device. If the identity of the device is in question, see the shop supervisor for resolution. Assure that proper authorization is received prior to performing the lockout procedure.

## **Lockout Procedure**

1. Notify all affected employees that a lockout is being performed and the reason for it.
2. Unload the subject lift. Shut it down and assure the disconnect switch is "OFF" if one is provided on the lift.
3. The authorized lockout person operates the main energy isolation device removing power to the subject lift. • If this is a lockable device, the authorized lockout person places the assigned padlock on the device to prevent its unintentional reactivation. An appropriate tag is applied stating the person's name, at least 3" x 6" in size, an easily noticeable color, and states not to operate device or remove tag. • If this device is a non-lockable circuit breaker or fuse, replace with a "dummy" device and tag it appropriately as mentioned above.
4. Attempt to operate lift to assure the lockout is working. Be sure to return any switches to the "OFF" position.
5. The equipment is now locked out and ready for the required maintenance or service.

## **Restoring Equipment to Service**

1. Assure the work on the lift is complete and the area is clear of tools, vehicles, and personnel.
2. At this point, the authorized person can remove the lock (or dummy circuit breaker or fuse) & tag and activate the energy isolating device so that the lift may again be placed into operation.

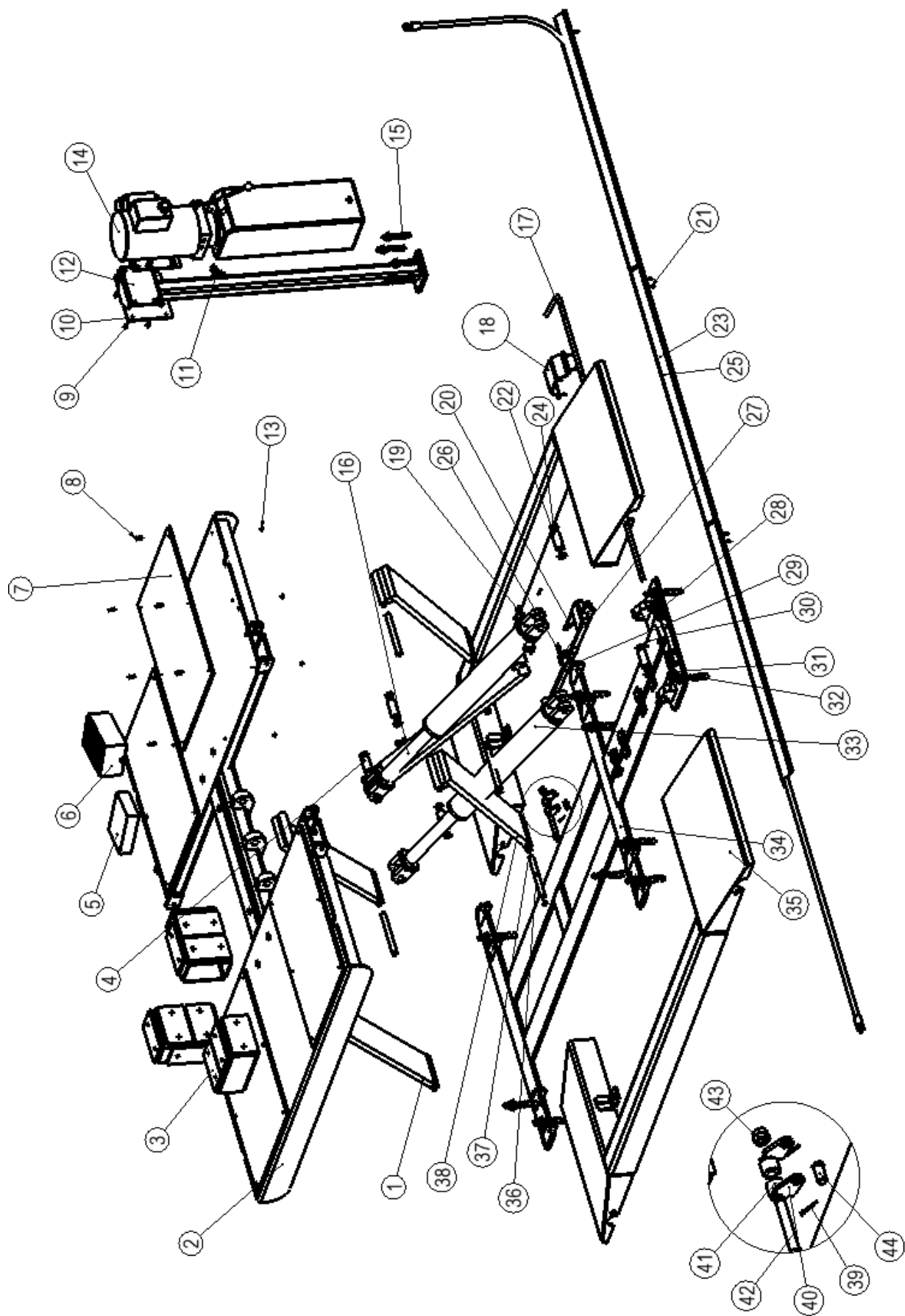

# PARTS BREAKDOWN

ITEM NO.	PART NUMBER	DESCRIPTION	QTY.
1	27103001	REAR SUPPORT	2
2	27100001	TOP STRUCTURE	1
3	47102700	HEIGHT ADAPTER ASSEMBLY	4
4	17102400	SHAFT	1
5	17106205	40MM RUBBER PAD	4
6	17106203	75MM RUBBER PAD	4
7	37100001	RUBBER PAD	4
8	3C200067	M6X20 SCREW	24
9	3C200081	SHCS M6X15	4
10	3C200024	6MM FLAT WASHER	8
11	3H000009	ELBOW PUMP FITTING	1
12	27103000	P/U STAND	1
13	3C200026	M6 NUT	28
14	37100252	POWER UNIT (220V)	1
	37100253	POWER UNIT (110V)	
15	3C100102	ANCHOR: 1/2" X 3-3/4"	4
16	27104101	LOCKING BAR	1
17	17106204	LONG UNLOCK HANDLE	1
18	27106201	UNLOCK HANDLE COVER WELDMENT	1
19	3C200077	ELBOW FITTING	2
20	27104100	GUIDE BAR	1
21	3C100127	TAPCON SCREW 3/16"	16
22	3C200001	25MM SNAP RING	10
23	37102800	PIPE COVER	3
24	17101111	CYLINDER PIN	4
25	37103900	177" HYDRAULIC HOSE	1
26	3C200068	M6X35 HEXAGON SOCKET SCREW	1
27	17101400	UNLOCK PLATE	2

ITEM NO.	PART NUMBER	DESCRIPTION	QTY.
28	3H000010	3/8 JIC T FITTING	1
29	3C200029	M6 NYLOCK NUT	1
30	37103600	9" HYDRAULIC HOSE	1
31	37103700	15" HYDRAULIC HOSE	1
32	3C100112	5/8" X 5" WEDGE ANCHOR	12
33	47006300	HYDRAULIC CYLINDER	2
34	27102001	BOTTOM FRAME	1
35	27105000	RAMP	2
36	17101101	SHAFT	8
37	3C200082	SNAP RING	16
38	27103002	FRONT SUPPORT	2
39	3C200069	COTTER PIN 3.2X20	3
40	17101800	LATCH RELEASE PIVOT	2
41	17101900	PLASTIC ROLLER	2
42	3C200070	M12x80 HEXAGON SOCKET SCREW	1
43	3C200071	NYLOCK NUT M12	1
44	3C200072	PIN SHAFT M12x24	2

# HEIGHT ADAPTER ASSEMBLY (47102700)

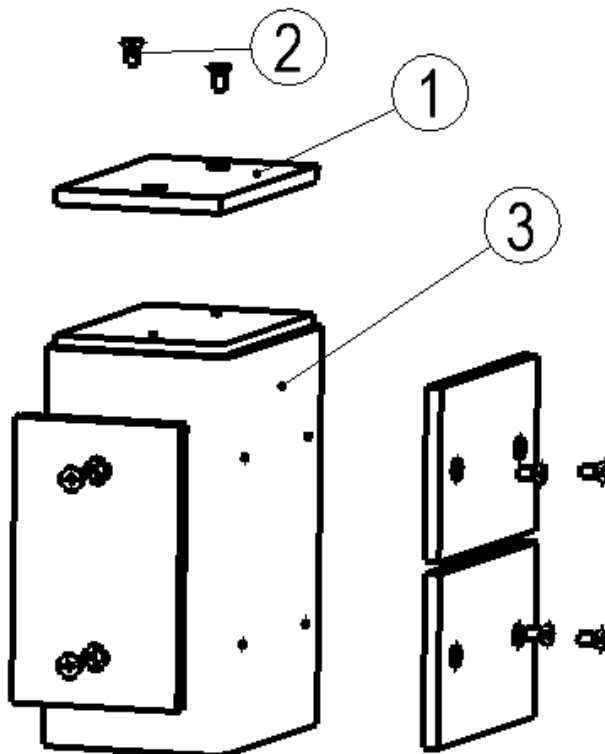

ITEM NO.	PART NUMBER	DESCRIPTION	QTY.
1	37102720	RUBBER PAD	4
2	3C200073	M6X12 ROUND HEAD HEX SOCKET SCREW	8
3	27102710	SUPPORT WELDMENT	1