

COATS®

12,000 lb. (5,455 kg)

Two Post Lift

3 Piece Front & Rear Arms

4T212SSR1(Symmetric)



Installation Manual Operation Manual Service Parts Manual

READ the manual thoroughly before installing, operating, servicing, or maintaining the lift. SAVE this MANUAL and ALL INSTRUCTIONS.

1601 J.P. Hennessy Drive, LaVergne, TN 37086 (800) 688-6496 or (615) 641-7533

Hennessy Canada: 2430 Lucknow Drive, Unit 9, Mississauga, Ontario L5S 1V3 (905) 672-9440 www.coatsgarage.com
HENNESSY INDUSTRIES INC. Manufacturer of AMMCO®, COATS® and BADA® Automotive Service Equipment and Tools.

Manual Part No.: 85611153 00

Revision: 6/17

Your new lift will provide years of dependable service if installed, operated and maintained properly. Read and be prepared to follow all safety, installation, operation, and maintenance instructions in this manual before installing and operating the lift. In addition, read and follow all safety and other info included on and with the lift before operating the lift. Keep this manual in a secure place for future reference, training and service part identification.

Table of Contents

UNLOADING PROCEDURE & LIFT PACKAGE CONTENTS4

WARRANTY5

Safety Instruction and Information Decal Kit.....8

Owner/Employer Responsibilities.....9

GENERAL REQUIREMENTS & LIFT SPECIFICATIONS 10

LIFT INSTALLATION FOR DIFFERENT OPTIONS 11

TOOLS REQUIRED and PRE INSTALLATION PROCEDURES 14

INSTALLATION PROCEDURE..... 15

OPERATING INSTRUCTIONS and LIFT MAINTENANCE 17

LIFT PROBLEM TROUBLESHOOTING GUIDE 20

Diagram #1: TOWER EXTENSIONS ASSEMBLY 22

Diagram #2: OVERHEAD CROSSMEMBER ASSEMBLY 23

Diagram #3: LIFT LEVELLING - COLUMN SHIMING - ANCHOR BOLTS..... 25

Diagram #4: EQUALIZING CABLES 26

Diagram #5: SAFETY RELEASE CABLE..... 27

Diagram #6: LIFT ARMS AND ARM RESTRAINS 28

Diagram #7: CARRIAGE AND ARM LOCK ASSEMBLY 30

Diagram #8: HYDRAULIC SYSTEM 31

Diagram #9: SAFETY LOCK COVER INSTALLATION..... 32

Diagram#10: Wiring Diagram 33

Diagram #11: SAFETY INSTRUCTIONS 34

IMPORTANT:

It is the shop owner's responsibility to provide a satisfactory installation area for the lift. Lifts should only be installed indoors on level concrete floors with a minimum of 4 inches (102mm) and 3000 psi (20.7MPa) concrete that has been aged a minimum of 30 days. Please consult a qualified individual if any doubt exists concerning proper installation and subsequent safe operation of the lift. Do not install the lift on asphalt or outdoors.

Prior to installation, it is the shop owner's responsibility to provide constant electrical power in the correct voltage, phase, etc., and all wiring for electrical hook-up of the lift. The shop owner must insure that the electrical installation conforms to local building and safety codes. Where required, the shop owner will provide an electrical isolation switch located in close proximity to the lift. This switch will have an emergency stop capability and isolate electrical power from the lift for servicing requirements.

Hydraulic oil cannot be shipped with the lift and will be supplied by either the shop owner or the installer. ISO 32 hydraulic oil (10W non detergent hydraulic oil) must be used to fill the reservoir tank before operating the lift.

It is the shop owner's responsibility to train all operators in lift operation and safety.

UNLOADING PROCEDURE & LIFT PACKAGE CONTENTS

For your information:

All lift components are grouped together in one package held at each end by steel frames.

Unpacking Procedure:

When the lift arrives on site:

- ✓ If possible, have lift unloaded in the installation area.
- ✓ Check for freight damage and report immediately to the shipping company.
- ✓ Check for missing parts and report immediately to the factory. 1-877-799-LIFT(5438) or (905) 847-1198

Main Components include:

- Power Side Column and Carriage Assembly – 1 pc (c/w equalizing cable, 2 arm restraint assemblies and 1 hydraulic cylinder assembly)
- Opposite Side Column and Carriage Assembly – 1 pc (c/w equalizing cable and 2 arm restraint assemblies and 1 hydraulic cylinder assembly)
- Column Extensions – 2 pc
- Overhead Crossmember – 2 pc (c/w 4 steel cable pulleys)
- Overhead Safety Shutoff Bar – 1 pc
- Arms – 4 pc (c/w arm restraint gear assemblies)
- Powerpack Assembly – 1 pc

Accessory and Hardware Box includes:

- Micro-switch for Overhead Safety Shutoff Bar - 1pc (c/w 2 mounting brackets and hardware)
- Baseplate Shims (6mm - 3mm - 1mm assortment) - Anchor Bolt Assemblies - 10 pc
- Arm Pins – 4 pc (c/w roll pins to secure them)
- Adjustable Rubber Lifting Pad Assembly – 4 pcs
- Stack Pad Adapter (3") – 4 pcs
- Stack Pad Adapter (6") – 4 pcs
- Truck Adapter – 4 pcs
- Rubber Door Guards – 2 pcs
- Outer Arm (Honda) Adapter – 2 pcs
- Hydraulic Hose – 1 long and 1 short
- Rubber Mounts for Powerpack - 4 pcs
- Safety Lock Release Cable – 1 pc (c/w 2 rubber tube and 8 pcs clamps)
- Safety Lock Cover – 2 pcs
- Fittings Box (bolts, washers, nuts, screws, cable ties, etc.)
- ALI - "Lifting It Right" Manual

- Automotive Lift Safety Tips Hang Card
- Automotive Lift, Operation, Inspection and Maintenance Manual
- Owner's Manual (this document)

WARRANTY

The lift model identified in this manual has the following warranty from date of purchase:

Structural Components - 5 years

Accessory Items - 90 days

Hydraulic and Other Components - 1 year

Labor - 1 year

The above items are warranted to be free of defects in material and workmanship to the original owner of the lift as follows: During the first year (90 days for accessories), those parts proven after inspection to be defective shall be repaired or replaced at the option of the manufacturer. Structural components are only warranted for an extended period of four years and if proven after inspection to be defective shall be repaired or replaced at the option of the manufacturer. This warranty does not extend to defects caused by ordinary wear, misuse, abuse, improper maintenance, shipping damage or where repairs have been attempted or made by anyone other than the manufacturer or a manufacturer certified technician. This warranty is exclusive and in lieu of all other warranties express or implied. In no event shall the manufacturer be liable for special, incidental, or consequential damages for any breach or delay in the performance of the warranty. The manufacturer reserves the right to change specifications, designs or add improvements to its product line without incurring any obligation to make such changes to products sold previously.

IMPORTANT SAFETY INSTRUCTIONS

When using your garage equipment, basic safety precautions should always be followed, including the following:

1. Read all instructions
2. Care must be taken as burns can result from touching hot parts
3. Do not operate equipment with a damaged cord or if equipment has been dropped or damaged – until it has been examined by a qualified service person
4. Do not let a cord hang over the edge of the table, bench, or counter or come in contact with hot manifolds or moving fan blades
5. Let equipment cool completely before putting away. Loop cord loosely around equipment when storing
6. To reduce risk of fire, do not operate equipment in the vicinity of open containers of flammable liquids (gasoline)
7. Adequate ventilation should be provided when working on operating internal combustion engines
8. Keep hair, loose clothing, fingers, and all parts of body away from moving parts
9. To reduce the risk of electric shock, do not use on wet surfaces or expose to rain
10. Use only as directed in this manual. Use only manufacturer's recommended attachments
11. ALWAYS WEAR SAFETY GLASSES. Everyday eyeglasses only have impact resistant lenses, they are not safety glasses

SAVE THESE INSTRUCTIONS

Safety Continued

Basic common sense safety precautions should always be followed when installing, operating and maintaining the lift as a risk of fire, electric shock, or injury may be present.

In addition:

1. Read and follow all safety instructions and decals included with the lift. Read and follow all safety instructions in this manual. Read and follow the ALI "Lifting It Right" manual (included with the lift). Always use the "Vehicle Lifting Points" reference guide when lifting a vehicle. Insure all materials stay up to date(www.autolift.org/)
2. Only trained and authorized personnel should position a vehicle and operate the lift. Do not allow customers or bystanders to operate the lift or be in the lift area.
3. Inspect the lift daily. Do not operate if potential problems have been identified or lift malfunctions. Do not operate if lift has damaged or broken components. Never walk or work under the lift unless all safety locks are completely engaged.
4. Never overload the lift. The rated capacity decal is located on the powerpack column. The hydraulic system on this lift is not designed to be a load holding devise. Mechanical safety locks must be engaged before proceeding under the lift, with vehicle servicing, or system maintenance. Never override operating controls. This is unsafe and will void the warranty.
5. Before driving a vehicle between the columns, position all arms to insure unobstructed entry. Do not hit or run over arms as this could damage the lift and/or vehicle.
6. Use all 4 arms to raise a vehicle. Position all lift pads to contact vehicle manufacturer's recommended lifting points. Raise lift slowly until all pads contact the vehicle. Check all pads for complete and secure contact with the vehicle. Check all arm restraints to insure they are engaged properly. Check that vehicle is stable on the lift. Only after confirming these procedures, raise the lift to desired working height.
7. Special care must be used when lifting pick-up trucks. Optional truck adapters may be required to reach manufacturer recommended lifting points. Always use these lifting points. Running boards and other installed accessories may also require optional adapters. Insure contents of the cargo box will not affect vehicle balance while on the lift.
8. **Important:** Removal or installation of heavier parts can change the vehicle's center of gravity on the lift resulting in a critical load shift. The vehicle may then be unstable. Plan ahead for this possibility to insure continued safety and refer to the vehicle manufacturer's service manual for recommended procedures.
9. Always keep the lift area free of obstructions and debris. Clean up grease and oil spills immediately.
10. Never raise a vehicle with passengers inside. Before lowering a vehicle, check the lift and lift area and remove all obstructions. Before removing vehicle from the lift or lift area, position arms to the drive through position and confirm an unobstructed exit.

Safety Instruction and Information Decal Kit

IMPORTANT: Review all safety information daily with all lift operators.

<p>CAUTION</p> <p>Lift to be used by trained operator only.</p>	<p>CAUTION</p> <p>Authorized personnel only in lift area.</p>	<p>WARNING</p> <p>Clear area if vehicle is in danger of falling.</p>	<p>WARNING</p> <p>Position vehicle with center of gravity midway between adapters.</p>
<p>CAUTION</p> <p>Use vehicle manufacturer's lift points.</p>	<p>CAUTION</p> <p>Always use safety stands when removing or installing heavy components.</p>	<p>WARNING</p> <p>Remain clear of lift when raising or lowering vehicle.</p>	<p>WARNING</p> <p>Avoid excessive rocking of vehicle while on lift.</p>
<p>CAUTION</p> <p>Use height extenders when necessary to ensure good contact.</p>	<p>CAUTION</p> <p>Auxiliary adapters may reduce load capacity.</p>	<p>WARNING</p> <p>Do not override self-closing lift controls.</p>	<p>WARNING</p> <p>Keep feet clear of lift while lowering.</p>

The messages and pictographs shown are generic in nature and are meant to generally represent hazards common to all automotive lifts regardless of specific style.
Funding for the development and validation of these labels was provided by the Automotive Lift Institute, PO Box 85 Cortland, NY 13045.
Replacement label sets may be obtained from the original lift manufacturer and ALI's member companies. They are protected by copyright.
www.autolift.org ©1992 by ALI, Inc. ALI/ML1015

The messages and pictographs shown are generic in nature and are meant to generally represent hazards common to all automotive lifts regardless of specific style.
Funding for the development and validation of these labels was provided by the Automotive Lift Institute, PO Box 85 Cortland, NY 13045.
Replacement label sets may be obtained from the original lift manufacturer and ALI's member companies. They are protected by copyright.
www.autolift.org ©1992 by ALI, Inc. ALI/ML1015

The messages and pictographs shown are generic in nature and are meant to generally represent hazards common to all automotive lifts regardless of specific style.
Funding for the development and validation of these labels was provided by the Automotive Lift Institute, PO Box 85 Cortland, NY 13045.
Replacement label sets may be obtained from the original lift manufacturer and ALI's member companies. They are protected by copyright.
www.autolift.org ©1992 by ALI, Inc. ALI/ML1015

ATTENTION:
MOTEUR NON PROTÉGÉ—PROTECTION EXTERIEURE CONTRE LA SURCHAUFFE DOIT ÊTRE ASSURÉE CONFORMEMENT AU CODE CE, PREMIÈRE PARTIE

CAUTION:
MOTOR NOT PROTECTED—EXTERNAL OVERHEAT PROTECTION IN ACCORDANCE WITH CE CODE, PART 1, MUST BE PROVIDED

COURANT ADMISSIBLE MINIMAL DE LA DÉVIATION: 20A
MINIMUM CIRCUIT IMPACTY OF CONDUCTOR IS 20 A.

COURANT NOMINAL MAXIMAL DU FUSIBLE DE LA DÉVIATION: 25 A.
MAXIMUM BRANCH CIRCUIT FUSE IS 25 A.

AVERTISSEMENT: IL EST DANGEREUX DE TROP ARROSER LE MATÉRIEL ET LES CÂBLES ÉLECTRIQUES
WARNING: IT IS DANGEROUS TO OVERSPRAY THE ELECTRICAL APPARATUS AND WIRING

SI CONNECTÉ À UN CIRCUIT PROTÉGÉ PAR DES FUSIBLES UTILISER DES FUSIBLES À UNE ACTION DIFFÉRÉE MARQUÉS "D"
IF CONNECTED TO A CIRCUIT PROTECTED BY FUSES USE TIME DELAY FUSE MARKED "D"

NE PAS UTILISER À UN NIVEAU INFÉRIEUR À CELUI DU PLANCHER DU GARAGE OU DU SOL
DO NOT USE BELOW GARAGE FLOOR OR GRADE LEVEL

CAUTION: RISK OF ELECTRIC SHOCK - DO NOT REMOVE COVER - NO USER SERVICEABLE PARTS INSIDE - REFER SERVICING TO QUALIFIED SERVICE PERSONNEL

SAFETY INSTRUCTIONS: IF ATTACHMENTS, ACCESSORIES OR CONFIGURATION MODIFYING COMPONENTS THAT ARE LOCATED IN THE LOAD PATH, AFFECT OPERATION OF THE LIFT, AFFECT THE LIFT ELECTRICAL LISTING OR AFFECT INTENDED VEHICLE ACCOMMODATION ARE USED ON THIS LIFT AND, IF THEY ARE NOT CERTIFIED FOR USE ON THIS LIFT, THEN THE CERTIFICATION OF THIS LIFT SHALL BECOME NULL AND VOID. CONTACT THE PARTICIPANT FOR INFORMATION PERTAINING TO CERTIFIED ATTACHMENTS, ACCESSORIES OR CONFIGURATION MODIFYING COMPONENTS.

This piece of garage equipment is specified by the manufacturer for Intermittent Operation with a maximum "on" time of 60 seconds and a corresponding "off" time of 540 seconds for the equipment.

52100100

SAFETY INSTRUCTIONS

Read operating and safety manuals before using lift.

SAFETY INSTRUCTIONS

Proper maintenance and inspection is necessary for safe operation.

SAFETY INSTRUCTIONS

Do not operate a damaged lift.

The messages and pictographs shown are generic in nature and are meant to generally represent hazards common to all automotive lifts regardless of specific style.

Funding for the development and validation of these labels was provided by the Automotive Lift Institute, PO Box 85 Cortland, NY 13045.

Replacement label sets may be obtained from the original lift manufacturer and ALI's member companies. They are protected by copyright.

www.autolift.org
© 1992 by ALI, Inc. ALI/ML1015

LIFT SAFETY and LIFT MAINTENANCE MUST BE PART OF YOUR DAILY ROUTINE

Owner/Employer Responsibilities

The owner/employer:

- Shall ensure that lift operators are qualified and that they are trained in the safe use and operation of the lift using the manufacturer's operating instructions; ALI/SM, "Lifting It Right" safety manual; ALI/ST, "Safety Tips" card; ANSI/ALI ALOIM, Standard for Automotive Lifts – Safety Requirements for Operation, Inspection and Maintenance; ALI/WL Series, ALI Uniform Warning Label Decals/Placards; and in the case of frame engaging lifts, ALI/LP-Guide, "Quick Reference Guide – Vehicle Lifting Points for Frame Engaging Lifts".
- Shall establish procedures to periodically inspect the lift in accordance with the lift manufacturer's instructions or ANSI/ALI ALOIM, Standard for Automotive Lifts – Safety Requirements for Operation, Inspection and Maintenance; and the employer shall ensure that lift inspectors are qualified and that they are adequately trained in the inspection of the lift.
- Shall establish procedures to periodically maintain the lift in accordance with the lift manufacturer's instructions or ANSI/ALI ALOIM, Standard for Automotive Lifts – Safety Requirements for Operation, Inspection and Maintenance; and the employer shall ensure that lift maintenance personnel are qualified and that they are adequately trained in the maintenance of the lift.
- Shall maintain the periodic inspection and maintenance records recommended by the manufacturer or ANSI/ALI ALOIM, Standard for Automotive Lifts – Safety Requirements for Operation, Inspection and Maintenance.
- Shall display the lift manufacturer's operating instructions; ALI/SM, "Lifting It Right" safety manual; ALI/ST, "Safety Tips" card; ANSI/ALI ALOIM, Standard for Automotive Lifts – Safety Requirements for Operation, Inspection and Maintenance; ALI/WL Series, ALI Uniform Warning Label Decals/Placards; and in the case of frame engaging lifts, ALI/LP-Guide, "Quick Reference Guide – Vehicle Lifting Points for Frame Engaging Lifts"; in a conspicuous location in the lift area convenient to the operator.
- Shall review and understand the proper requirements outlined in ANSI/ALI ALIS, Safety Requirements for Installation and Service of Automotive Lifts.
- Shall consult with a qualified person to address seismic loads and other local or state requirements.

GENERAL REQUIREMENTS & LIFT SPECIFICATIONS

12,000 lb. Capacity (3,000 lbs. per lift pad)

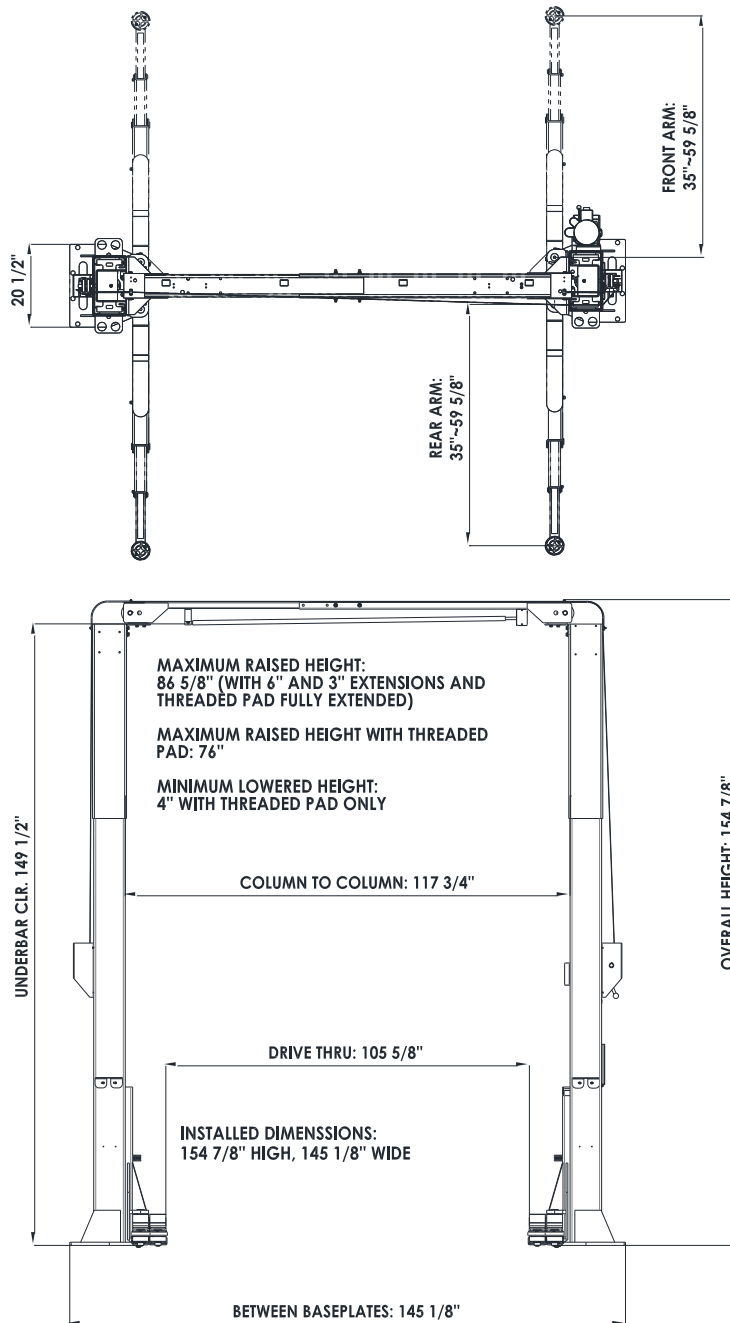

Lift should only be installed on level concrete floors with a minimum of 4 inches and 3000 psi (20.7MPa) concrete that has been aged a minimum of 30 days. A qualified person should be consulted to address seismic loads and other local or state requirements.

A constant supply of 230 volt, 1PH, 60Hz, 20 amp electrical is required for this lift.

This lift is designed for INDOOR use only, outdoor installation is prohibited.

LIFT INSTALLATION FOR DIFFERENT OPTIONS

This lift is capable to be installed with the following option(s).

- Installed as “low and wide”.

Take bay dimensions and ceiling height into consideration as well.

Follow the diagrams below to choose an installation.

Tower extension:

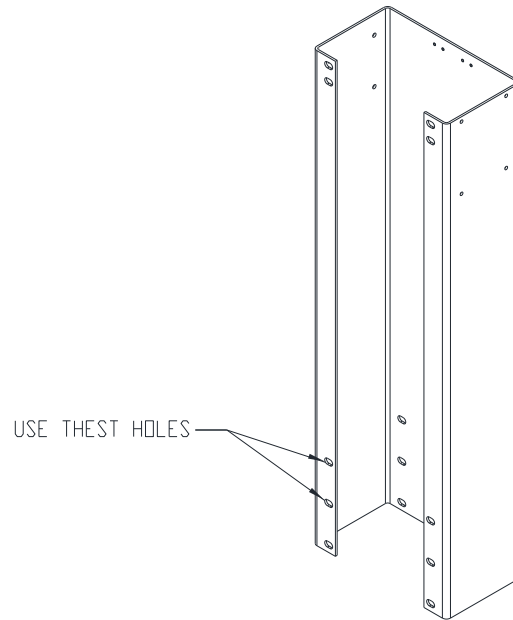

Crossbeam:

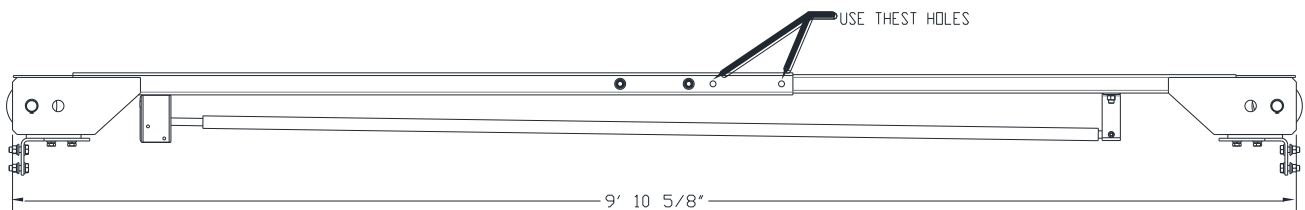

Cable Anchor Locations:

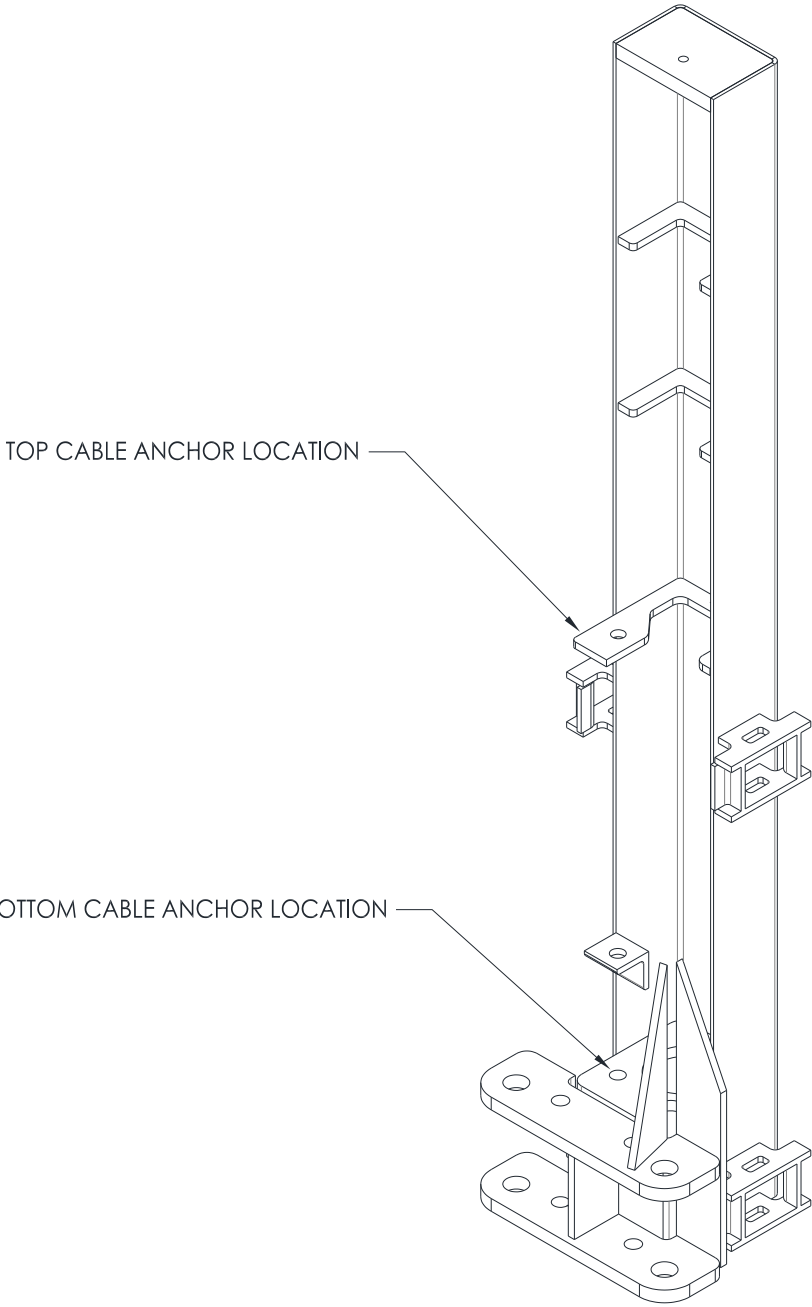

BAY DIMENSION REQUIREMENT

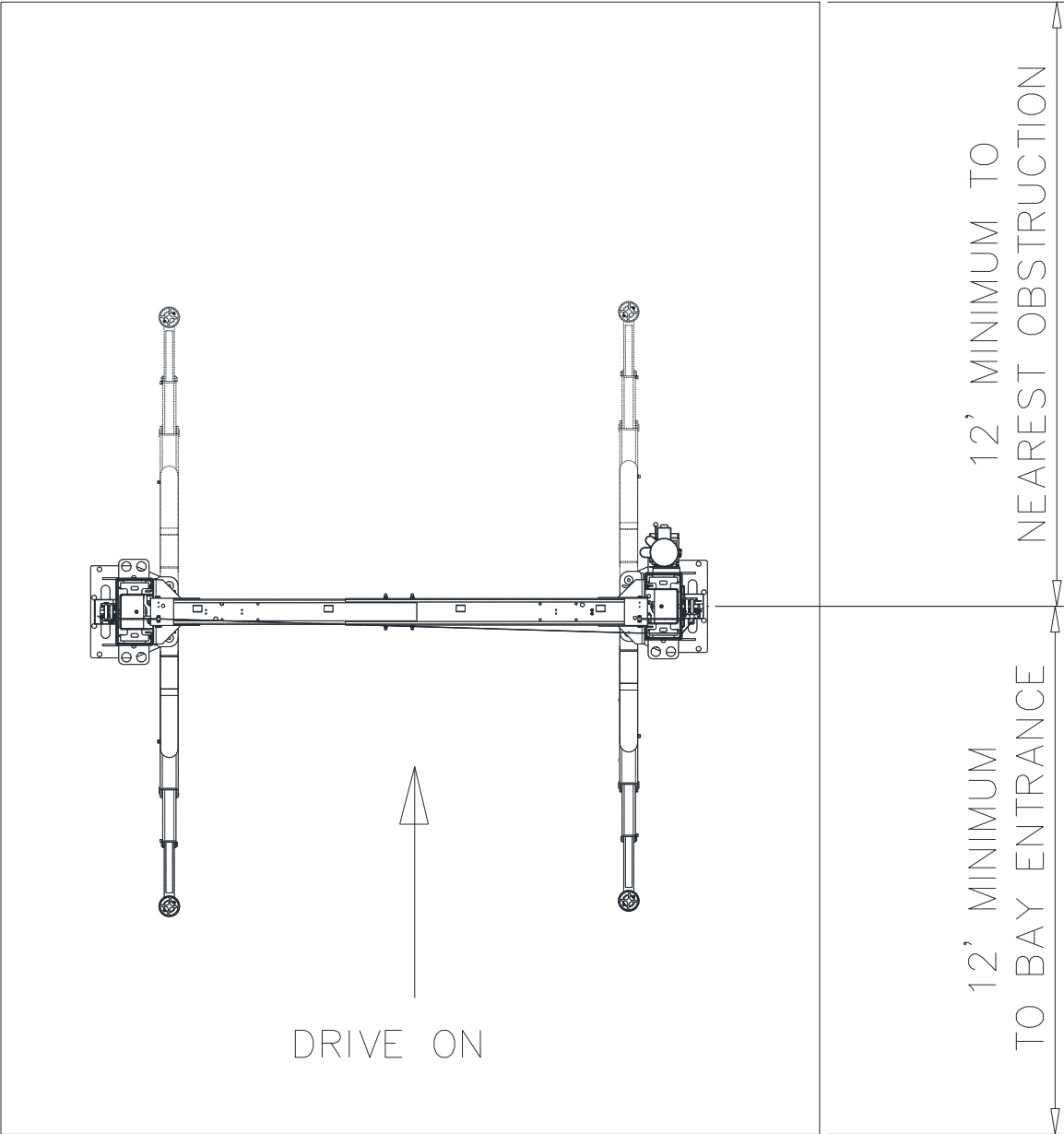

TOOLS REQUIRED and PRE INSTALLATION PROCEDURES

Tools Required: Gather all the tools listed below.

- 4" x 4" Wooden Blocks (for unpacking)
- 16ft. Measuring Tape
- Chalk Line and Chalk
- Side Cutters
- Crow Bar
- Metric Wrenches and Ratchet Set
- SAE Wrenches and Ratchet Set
- Metric and SAE Allen Key Sets
- Hammer
- Screwdrivers
- 12 ft. Step Ladders - 2
(2 people using 12 ft. ladders should install the overhead crossmember assembly)
- 4 ft. Levels - 2
- Rotary Hammer Drill with 3/4" diameter Masonry Drill Bit

Pre Installation Procedures

Before proceeding with installation, read the installation manual and insure all instructions are fully understood and all component parts are accounted for.

1. In the installation area, identify the center line of the bay and mark the floor. Also mark the center of bay entrance door. Connect these two points with a short chalk line in the area where lift will be located. Draw a second chalk line at 90° to locate the positions of both lift columns. Insure each lift column is equal distance from bay centerline and each baseplate maintains a minimum distance of 6 inches from any floor seam. Do not install if floor has cracks or deterioration that could affect lift lift stability. The shop owner is responsible for confirming there are no obstructions in the installation area like floor drains, under floor piping or electrical conduit that could be damaged or prevent safe lift installation and secure lift anchoring. Check ceiling for beams or heating ducts and walls for protruding structures, etc.. The Lift have two possible overall heights – 159.25" inches or 155.25" inches. Confirm that the overall height you intend to install will fit in the bay. Insure the lift can be safely installed in the position you have marked out on the bay floor.
2. Place the lift on wooden blocks so that the steel shipping frames can be removed.
3. Remove protective wrapping. Clear installation area of all packaging materials.
4. Unbolt steel shipping frames and remove from installation area.
5. Carefully remove top column and lay on the floor (carriage side up).
6. Carefully remove column extensions (2 pc), cross-member (3 pc), overhead safety bar, arms (4 pc), powerpack and hardware box from the lower column.
7. Identify powerpack column (reference diagram #1). Move (carriage side up) to appropriate location placing the baseplate end on your floor marks. Similarly, move the second column to the opposite location.

INSTALLATION PROCEDURE

See the Installation and Parts Reference section of this manual for diagrams and parts lists that will assist you during the installation process . Use these diagrams and parts lists together with the following written instructions. Insure the lift installation complies with ANSI/ALI/ALIS, Safety Requirements for Installation and Service of Automotive Lifts.

1. With columns lying on the ground (carriage side up), tightly fasten one column extension to one column using bolts, washers and nuts provided (reference diagram #1). Use the appropriate bolt hole locations to achieve either a 159 inch overall height. Repeat this procedure with second column.
2. Layout all pieces of the overhead cross-member on the floor and fasten tightly together using bolts, washers and nuts provided (reference diagram #2).
3. Identify all parts for overhead safety shut-off bar (reference diagram #2). Tightly fasten these parts to overhead cross-member with bolts, washers and nuts provided.
4. Raise (stand up) each column so that its base plate is located on the floor marking you made earlier. Confirm that base plate angles and measurements between columns match lift specifications on page 10. **Use extreme caution to insure the columns do not fall over.** Secure base plate of the most level column by installing one only anchor bolt.
5. For optimum safety, two installers should lift and secure the overhead cross-member to both columns using bolts, washers and nuts provided (reference diagram #2). Hand tightens all cross-member nuts and bolts. Final tightening is completed in step 9.
6. Using two 4 ft. levels and required shims, level each column vertically on all four sides (reference diagram #3). **Use extreme caution to insure the columns do not fall over. IMPORTANT:** When leveling each column using anchor bolts provided, do not use more than $\frac{3}{4}$ inch (19 mm) of shims under any area of the base plate. Use a 4 ft. level to confirm the overhead cross-member is also level and at 90 degrees to both columns.
7. Drill and install all anchor bolts, washers and nuts (reference diagram #3). Insure that each nut is torqued to 110 ft-lbs (149 Nm). ***This should be checked monthly.***
8. One equalizing cable comes partially installed on each carriage. Before feeding a cable up its column to the overhead cross-member, insure the cable is properly seated around the lower pulley at the base of each column (reference diagram #4). Route each cable up its column, over the appropriate pulleys in the overhead cross-member, and lower it down to the opposite carriage. Insure both equalizing cables are properly seated in overhead cross-member pulleys. Thread one nut to its farthest point on each equalizing cable. Insert threaded end into appropriate location on the carriage. Install and hand tighten second nut to secure each cable. Final equalizing cable adjustment is step 17. Install two bolts and nuts to prevent unintentional cable displacement (reference diagram #4).
9. Completely tighten both sides of the overhead cross-member to its column.
10. Identify component parts for the safety release cable (reference diagram #5). Install safety release cable so that safety locks in both columns will completely disengage when lift is lowered. Final safety release cable adjustment is step 16.
11. Identify parts to install arms (reference diagram #6). Install all 4 arms and arm pins. Secure each arm pin by inserting roll pin provided. Arm restraint adjustment is step
12. Install rubber mounts on power pack bracket. Keeping these rubber mounts between the power pack and the mounting bracket, securely fasten power pack to the mounting bracket.

13. Identify parts for hydraulic system installation (reference diagram #8). Locate "T" fitting on the power pack. Tightly fasten hydraulic lines to "T" fitting and appropriately locate two hydraulic lines to the corresponding hydraulic cylinders (short hose for the cylinder on the power side, long hose for non-power side). Tightly fasten all hydraulic lines and secure these lines to both columns and overhead cross-member using hardware provided. Insure that nothing will rub or wear the hydraulic lines.
14. Attach micro switch to overhead safety bar bracket on power pack side of overhead cross-member. Wire power pack to shop electrical system.
15. Fill power pack reservoir with ISO 32 hydraulic oil.
16. **Operate the lift with no vehicle and no other weight.** Raise lifting carriages approximately 30 inches. Confirm that safety locks on both sides engage properly while lift is being raised. Verify that both lifting cylinders are properly seated in the base plate locator hole. Continue raising lift to full height confirming safety locks are engaging. Adjust safety release cable to insure safety locks can be completely disengaged while lowering lift (reference diagram #5). Insure that no people or obstacles are near the lift when adjusting the safety release cable. Lower lift completely. Raise and lower the lift at least three times or until all air in the hydraulic system is removed.
17. After confirming that all air has been bled from the hydraulic system, adjust equalizing cable tension as follows: (also reference diagram #4) **(Step 1)** Hold top of threaded stud with a wrench to prevent it from rotating. **(Step 2)** Tighten nut "B" until all loose slack is removed from the cable. Do not over tighten. **(Step 3)** Firmly tighten nut "A" to lock cable in place. Repeat this process for the other cable insuring both cables have the same degree of tightness.
18. Raise lifting carriages approximately 12 inches off the floor. Choose one arm and align arm restraint gear with locking plunger insuring both components mesh smoothly and totally (reference diagram #6). Completely tighten all arm restraint gear locking bolts to maintain this position. Lower carriage to the floor to insure arm restraint disengages in the down position. Raise the lift 12 inches off the floor to insure arm restraint engages smoothly and totally. Repeat this process with the remaining 3 arms. Raise and lower the lift once more to confirm all arm restraints totally engage and disengage smoothly.
19. Install safety lock cover on each column (reference diagram #9).
20. To avoid damage, safety instruction and information decals are not applied at the factory but shipped with the lift. The ALI - WL101 Series Label Kit must be applied to lift columns before the lift is used (reference diagram #101). **Insure that all lift operators are trained in all points covered by this label kit.**
21. **Operate the lift with a vehicle.** Raise and lower the lift three times. Confirm all the operational functions, equalizing cables and safety lock work well.

Insure this manual along with all operation, inspection and maintenance instructions are delivered to the owner/user/employer

Final Checkout Procedure of Assembled Lift

- ✓ Check hydraulic oil level in reservoir. Confirm hydraulic connections are tight with no leaks
- ✓ Confirm that both columns are level and properly shimmed with all anchor bolts torqued to 110 ft.-lbs. (149 Nm). Confirm lift stability
- ✓ Confirm that all electrical components have been wired properly and are operational
- ✓ Confirm that all cables are adjusted properly
- ✓ Confirm safety locks and arm restraints are functioning properly
- ✓ Lubricate all lubrication points

OPERATING INSTRUCTIONS and LIFT MAINTENANCE

LIFT OPERATION: Before lifting a vehicle, insure all operators are qualified, have been trained and are following all safety instructions. Read and follow the ALI "Lifting It Right" manual included with the lift. **Always** use the "Vehicle Lifting Points" reference guide when lifting a vehicle (CD included with the lift). Insure all materials stay up to date >>> www.autolift.org/ (see example of SAE J2184 standard below)

Insure the vehicle is securely positioned on the lift using manufacturer's recommended lifting points. Insure all arm restraints are totally engaged. Never allow anyone under the lift when raising or lowering it with or without a vehicle. Always confirm safety locks on both sides of the lift are completely engaged before proceeding under a vehicle.

Lift electrical operating controls are located on the power pack (one "up" button for raising the lift and one "down" lever for lowering the lift). Before lowering, slightly raise the lifting carriages to release pressure from both safety locks. Two hands must be used when lowering the lift. One hand must operate the safety lock release lever (located on the column above the powerpack) and one hand must operate the "down" lever. Make certain the safety locks do not accidentally re-engage while lift is being lowered. Customers and bystanders should not be in the lift area.

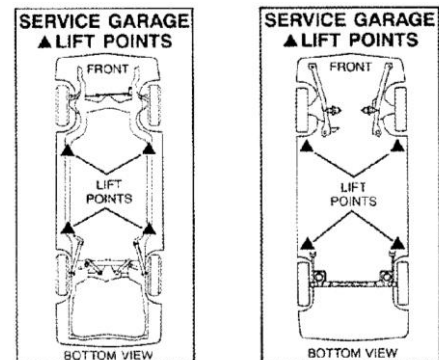

Typical Label Drawings
Reprinted with permission from SAE J2184
©2000 Society of Automotive Engineers, Inc.

LIFT MAINTENANCE: Before maintaining, servicing or repairing the lift, insure that an acceptable "lock out/tag out device is activated.

The following minimum maintenance schedule must be performed by the owner and/or lift operator:

- DAILY:**
- Raise and lower the lift (with no vehicle) at the beginning of each shift to verify it is operating properly and carriages are level. Confirm all arm restraints engage and disengage smoothly and totally and telescoping arms have no excessive movement.
 - Check all hydraulic fittings and lines for damage or leaks. Check electrical wiring for damage. Check all moving parts for uneven or excessive wear. Repair or replace all damaged, worn, or broken components immediately.
 - Remove oil/grease on all lift pads.

WEEKLY: - Check hydraulic fluid in power pack reservoir. (confirm no leaks before topping up)
- Check equalizing cable adjustment. Check safety lock release cable adjustment.

MONTHLY: - Check that all anchor bolts are torqued to 110 ft-lbs (149 Nm).
- Clean and lubricate arm restraints. (confirm all components are in good condition)
- Lubricate safety locks in both columns.
- Check that overhead safety shutoff is operating properly.

EVERY TWO MONTHS: - Remove and grease arm pins – reinstall insuring secure fit.
- Clean and re-grease slide block channel in both columns.
- Clean and lubricate all cable pulleys.

EVERY YEAR: - Arrange for a Trained Lift Service Person to inspect and certify all aspects of the lift as per "Automotive Lift Operation, Inspection and Maintenance" (ALOIM) guidelines. Confirm that both equalizing cables meet the standard outlined on page 13

EVERY TWO YEARS: - Change and replace hydraulic oil in cylinders and power pack.

Lubrication Specifications: - where grease is required use a multi-purpose lithium grease
- where lubricating oil is required use WD-40 or a SAE 30 oil
- where hydraulic oil is required use ISO 32 – 10W non detergent hydraulic oil.

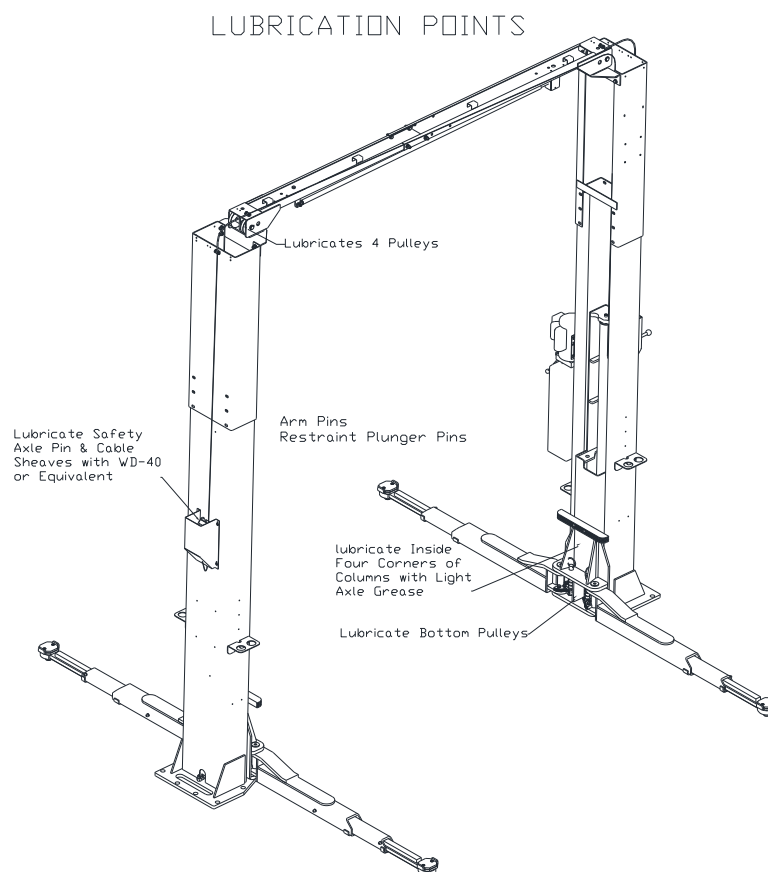

The following criteria will determine when an equalizing cable is no longer acceptable for service:

- 12 randomly distributed broken wires in one lay or four broken wires in one strand in one lay in running ropes
- one outer wire broken at the contact point with the core of the rope, which has worked its way out of the rope structure and protrudes or loops out from the rope structure
- wear of one-third the original diameter of outside individual wires
- kinking, crushing, birdcaging, or any other damage resulting in distortion of the rope structure
- evidence of heat damage from any cause
- reduction from nominal diameter greater than those listed in the following table:

Rope Diameter (inch)	Maximum allowable reduction from Nominal Diameter (inch)
Less than or equal to 5/16	1/64
More than 5/16	1/32
More than 1/2 to	3/64

Note: Attention shall be given to end connections. Upon development of two broken wires adjacent to socket end connections, the rope shall be resocketed or replaced. Resocketing shall not be attempted if the resulting rope length will be insufficient for proper operation.

LIFT PROBLEM TROUBLESHOOTING GUIDE

The following are some suggestions to consider if problems are encountered with the lift. Please call a Trained Lift Service Person for further clarification and information.

1. Lift does not operate: Possibilities include - blown fuse or tripped circuit breaker – tripped thermal overload on motor – defective "up" button. Call a qualified electrician for all wiring questions.
2. Motor runs but lift does not rise: Possibilities include – low hydraulic oil level (check reservoir tank) - dirt under check valve (press "down" lever and "up" button at the same time for 10-15 seconds. This will clear small contaminants. If this fails clean check valve ball and seat by removing valve cover). Call a Trained Lift Service Person if problem continues.
3. Motor noise (drone or hum) but will not run: Possibilities include – low voltage, faulty wiring or faulty capacitor (call electrician to confirm) – lift is overloaded (insure vehicle weighs less than rated lift capacity).
4. Lift falters or jerks when it is raised or lowered: Possibilities include – air in the hydraulic system (cycle lift all the way to the top and completely lower 3 – 4 times. If this does not solve the problem call a Trained Lift Service Person.
5. Excessive noise when raising or lowering lift: Possibilities include – pulley assemblies need lubricating – cable is off the pulleys – carriage sliders need grease – carriage sliders are broken. Do not operate the lift with broken or damaged carriage sliders or dislodged cable. Replace immediately.
6. Lifting carriages are unequal when raised: Possibilities include – improperly adjusted equalization cables – air in the hydraulic system. Adjust cables or call a Trained Lift Service Person to correct the problem.

Replace all worn or broken parts and components only with manufacturer approved/supplied parts and components

Replacement parts may be purchased from your local lift supplier or the manufacturer at 1 - 877 - 799 - LIFT (5438) or (905) 847 - 1198

LIFT ILLUSTRATIONS and PARTS LISTS

The diagrams below identify the main components and the order in which they are to be installed. Numbers correspond to installation diagrams found in the chart below and on following pages. Page numbers for each diagram is also found in the chart below. These diagrams, along with related parts lists, will assist you when installing and servicing this lift. Please insure these lift diagrams and parts lists are kept in a secure place for quick reference.

Diagram #1: TOWER EXTENSIONS ASSEMBLY

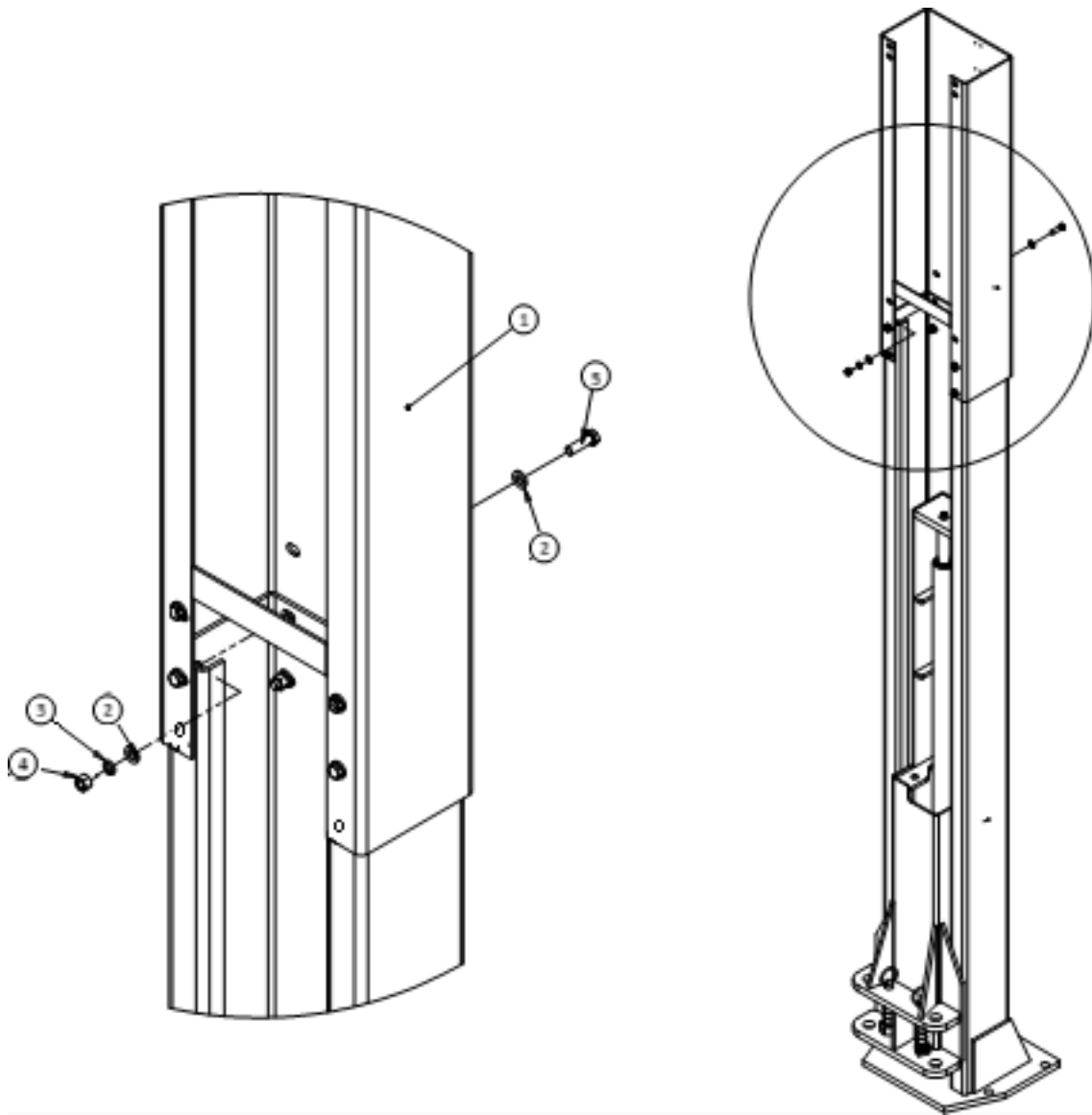

ITEM NO.	PART NUMBER	DESCRIPTION	QTY.
1	22120002	EXTENSION WELDMENT	2
2	3C000054	12MM PLAIN WASHER	32
3	3C000055	12MM SPRING LOCK WASHER	16
4	3C000057	M12 HEX NUT	16
5	3C000056	M12 HEX BOLT	16

Diagram #2: OVERHEAD CROSSMEMBER ASSEMBLY

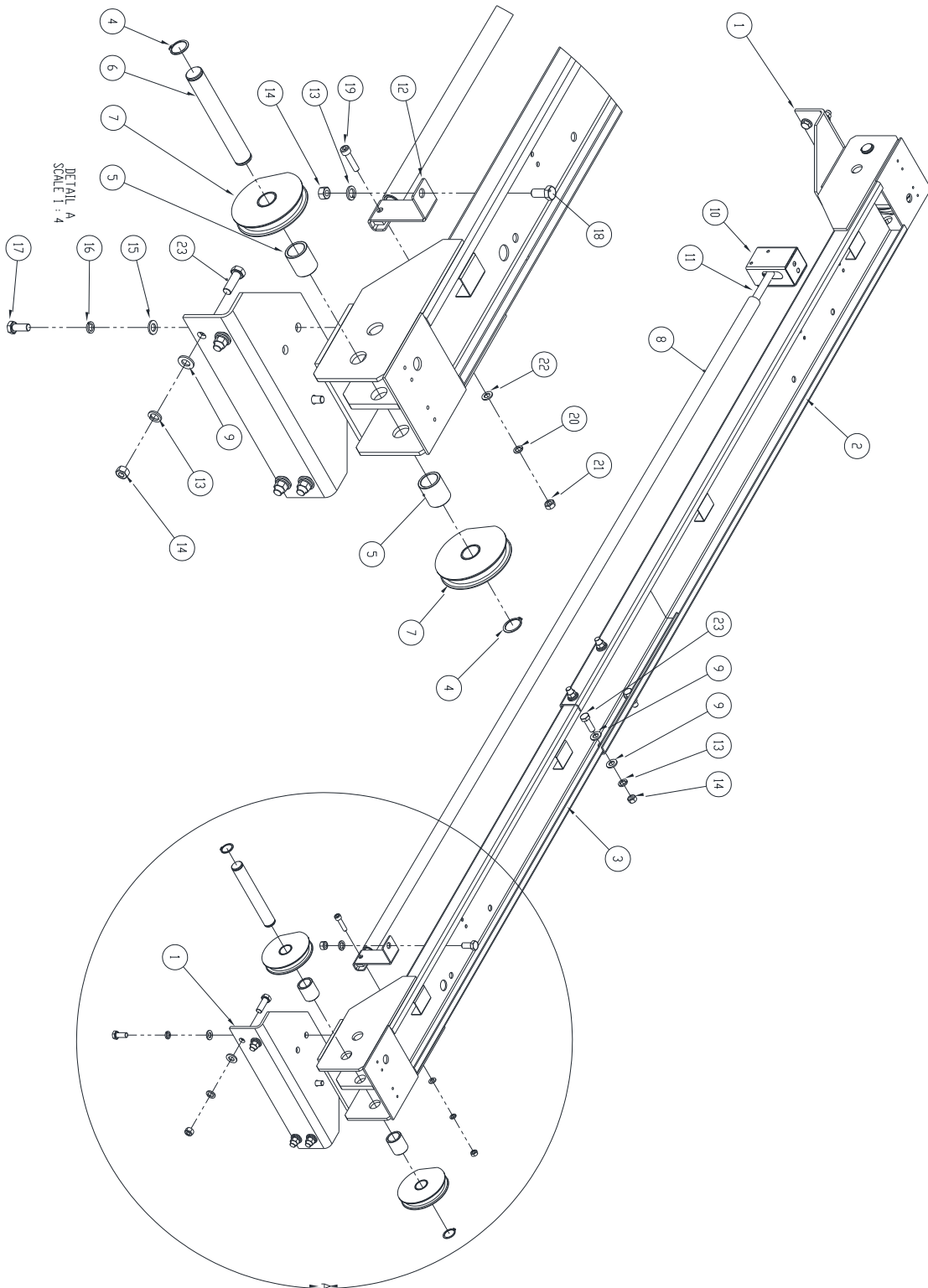

ITEM NO.	PART NUMBER	DESCRIPTION	QTY.
1	12120066	Bracket	2
2	22120008	beam outside	1
3	22120009	beam inside	1
4	3C200001	25MM SNAP RING	4
5	12120061	separate cover	4
6	12120065	long axis	2
7	42120022	TOP EQU. PULLEY	4
8	12100103	SOFT FOAM TUBE	1
9	3C200015	12MM FLAT WASHER	24
10	42100010	ETL APPROVE SAFETY BOX	1
11	22100014	Safety Bar	1
12	12100102	Bracket of Safety Bar	1
13	3C200017	12MM LOCK WASHER	13
14	3C200012	M12 NUT	13
15	3C200011	10MM FLAT WASHER	6
16	3C200020	10MM LOCK WASHER	6
17	3C200013	M10X25 HEX BOLT	6
18	3C200014	M12X25 HEX BOLT	1
19	3C200010	M8X35 SOCKET CAP SCREW	1
20	3C200021	8MM LOCK WASHER	1
21	3C200003	M8 NUT	1
22	3C200009	8MM FLAT WASHER	1
23	3C200043	M12X35	12

Diagram #3: LIFT LEVELLING - COLUMN SHIMMING - ANCHOR BOLTS

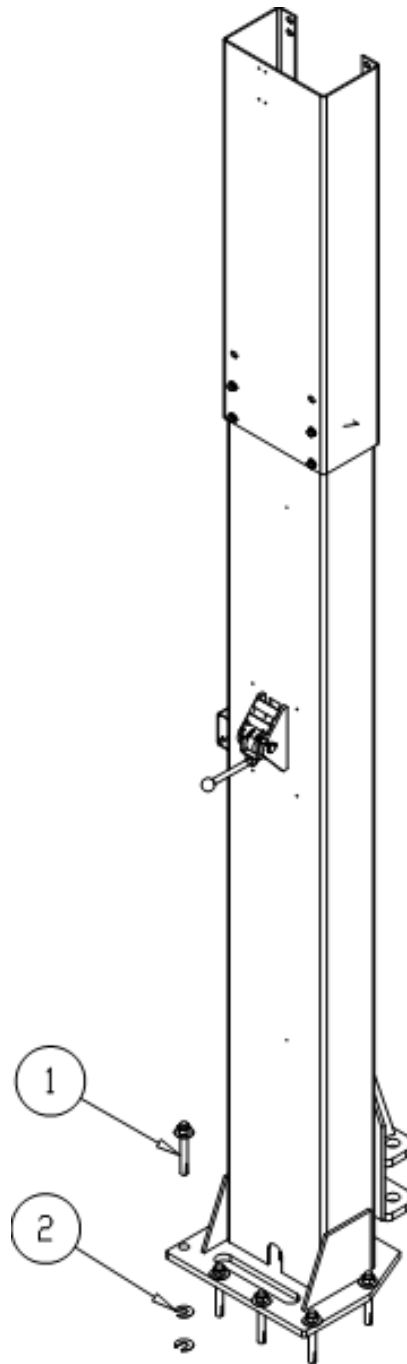

ITEM NO.	PART NUMBER	DESCRIPTION	QTY.
1	12120106	ANCHOR STUD, WASHER & NUT	12
2	32100540	6MM SHIM	6
	32100541	3MM SHIM	10
	32100542	1MM SHIM	10

Diagram #4: EQUALIZING CABLES

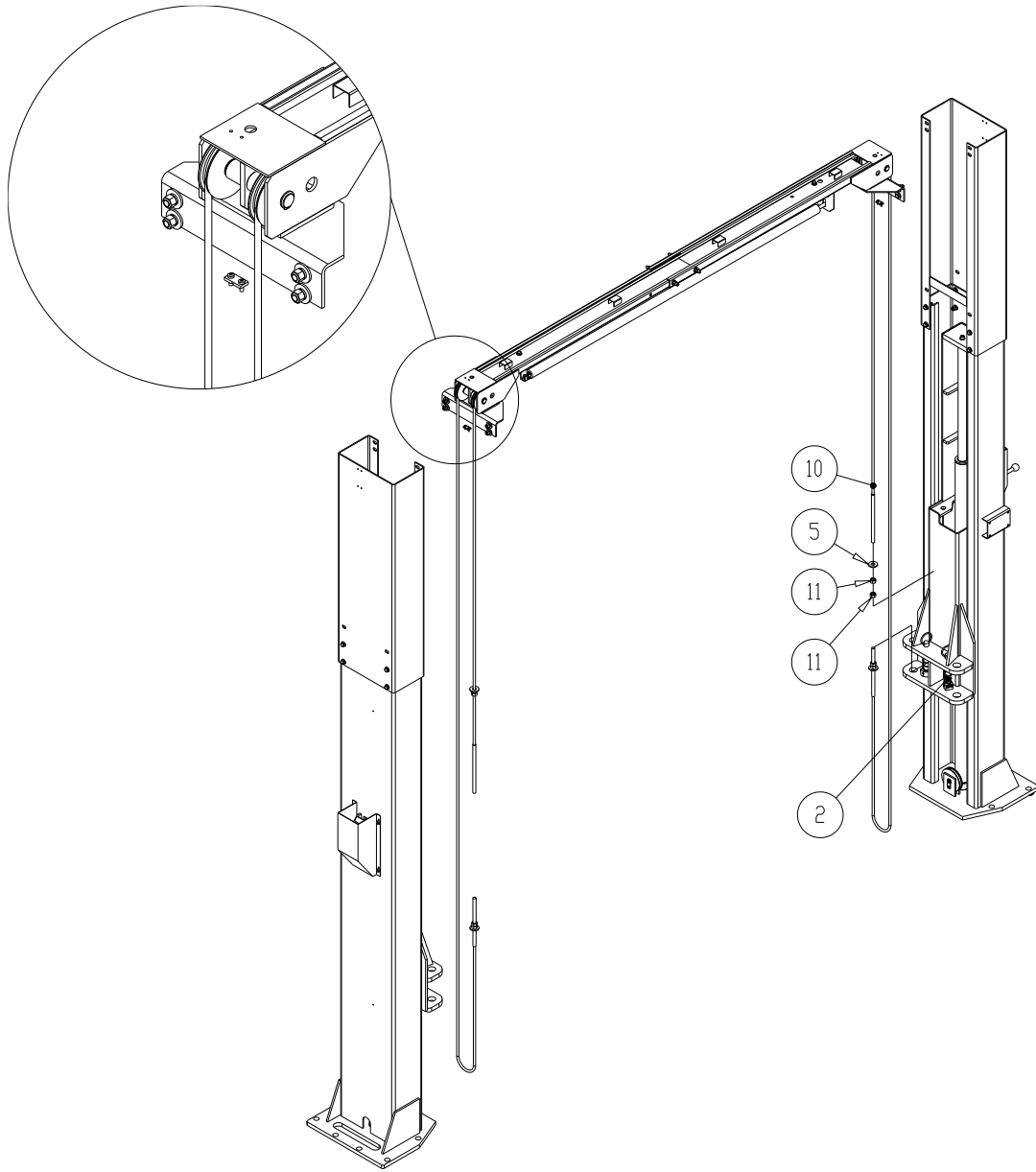

ITEM NO.	PART NUMBER	DESCRIPTION	QTY.
2	42120004	ARM LOCK	4
5	3C000058	M16 WASHER	4
10	12120099	CABLE	2
11	3C000059	M16 NUT	8

Diagram #5: SAFETY RELEASE CABLE

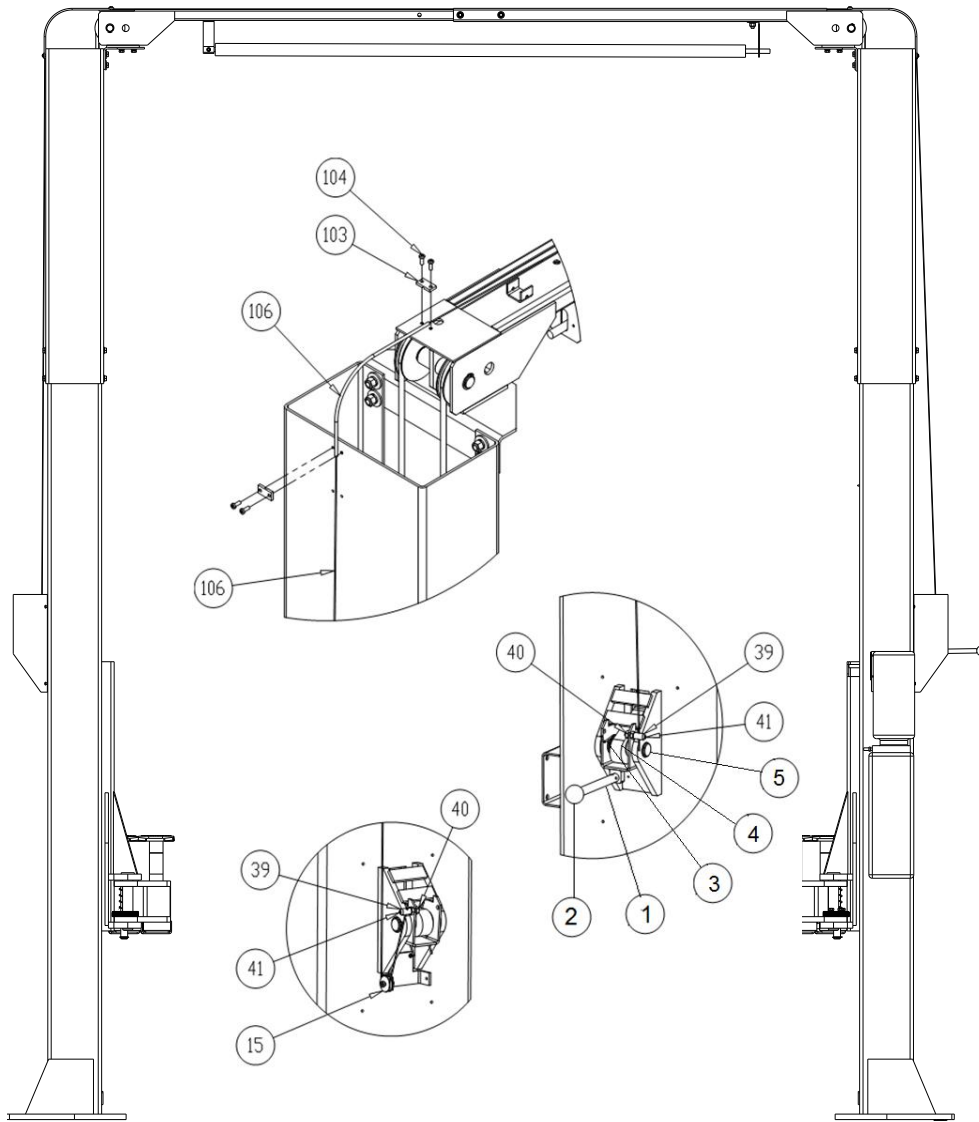

ITEM NO.	PART NUMBER	DESCRIPTION	QTY.
1	12120024	LEVER	1
2	12120025	PLASTIC BALL	1
3	12100078	SAFETY LOCK SPRING	2
4	12120013	SAFETY LOCK	2
5	12120012	SFAETY LOCK SHAFT	2
15	12120016	SAFETY CABLE PULLEY	1
39	3C000058	SAFETY RELEASE CABLE CLAMP	2
40	12100021	M8 NUT	2
41	3C000061	M6 SET SCREW	4
103	12120078	HOSE CLAMP	8
104	3C200045	M6x20 CROSS RECESSED SCREW	8
106	12120080	SAFETY CABLE HOSE	2

Diagram #6: LIFT ARMS AND ARM RESTRAINS

Rear Arm (Driver Side: 42125002, Passenger Side: 42125001)
Front Arm (Driver Side: 42125001, Passenger Side: 42125002)

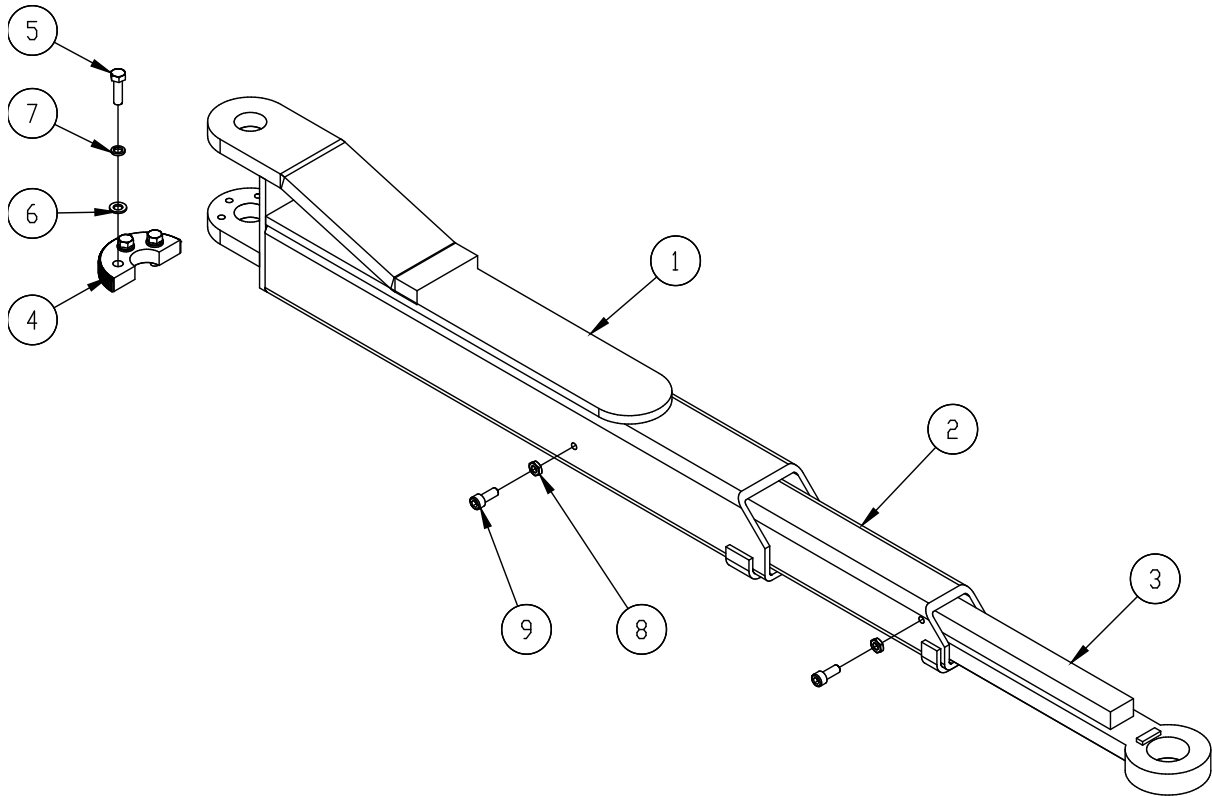

ITEM NO.	PART NUMBER	DESCRIPTION	QTY.
1	22120010	DRIVER SIDE FRONT OUTER ARM WELDMENT	1
	22120017	PASSENGER SIDE FRONT OUTER ARM WELDMENT	1
2	22105015	DRIVER SIDE FRONT MIDDLE ARM WELDMENT	1
	22125016	PASSENGER SIDE FRONT MIDDLE ARM WELDMENT	1
3	22125014	DRIVER SIDE FRONT INNER ARM WELDMENT	1
	22125013	PASSENGER SIDE FRONT INNER ARM WELDMENT	1
4	12120076	HALF GEAR	4
5	3C200018	M10X35 HEX BOLT	12
6	3C200011	10MM FLAT WASHER	12
7	3C200020	10MM LOCK WASHER	12
8	3C200047	M10 JAM NUT	8
9	3C200019	M10X25 SOCKET SCREW	8

Arm Accessories



4X 22120007
ARM PIN



4X 3C200007
6MMX40MM ROLLER PIN

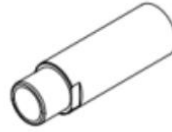

4X 19005101, 6" EXTENSION



4X 19005102, 3" EXTENSION

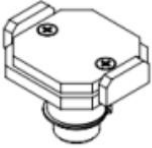

4X 42100042, LIFTING PAD

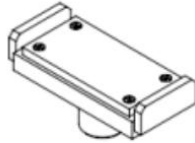

2X 49000057
7" GM ADAPTER

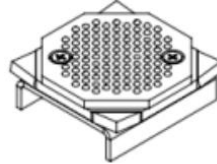

2X TLS2PHA
HONDA ADAPTER

Diagram #7: CARRIAGE AND ARM LOCK ASSEMBLY
(42120005)

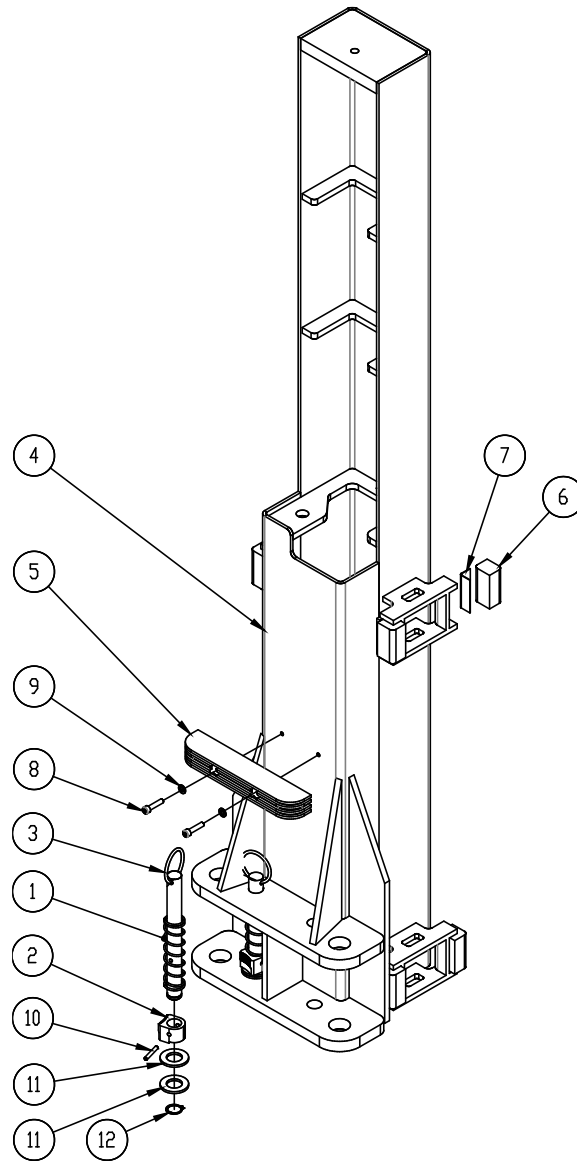

ITEM NO.	PART NUMBER	DESCRIPTION	QTY.
1	12120046	SPRING	4
2	12120045	GEAR INSIDE	4
3	42120004	GEAR AXIS PIN	4
4	22120005	CARRIAGE WELDMENT	2
5	12100145	DOOR GUARD	2
6	12120043	SLIDER BLOCK	16
7	12120133	SLIDER SHIMS	16
8	3C200010	M8X35 SOCKET CAP SCREW	4
9	3C200009	8MM FLAT WASHER	4
10	3C200007	6MMX40MM ROLLER PIN	4
11	3C200042	27MM FLAT WASHER	8
12	3C100069	1" SNAP RING	4

Diagram #8: HYDRAULIC SYSTEM

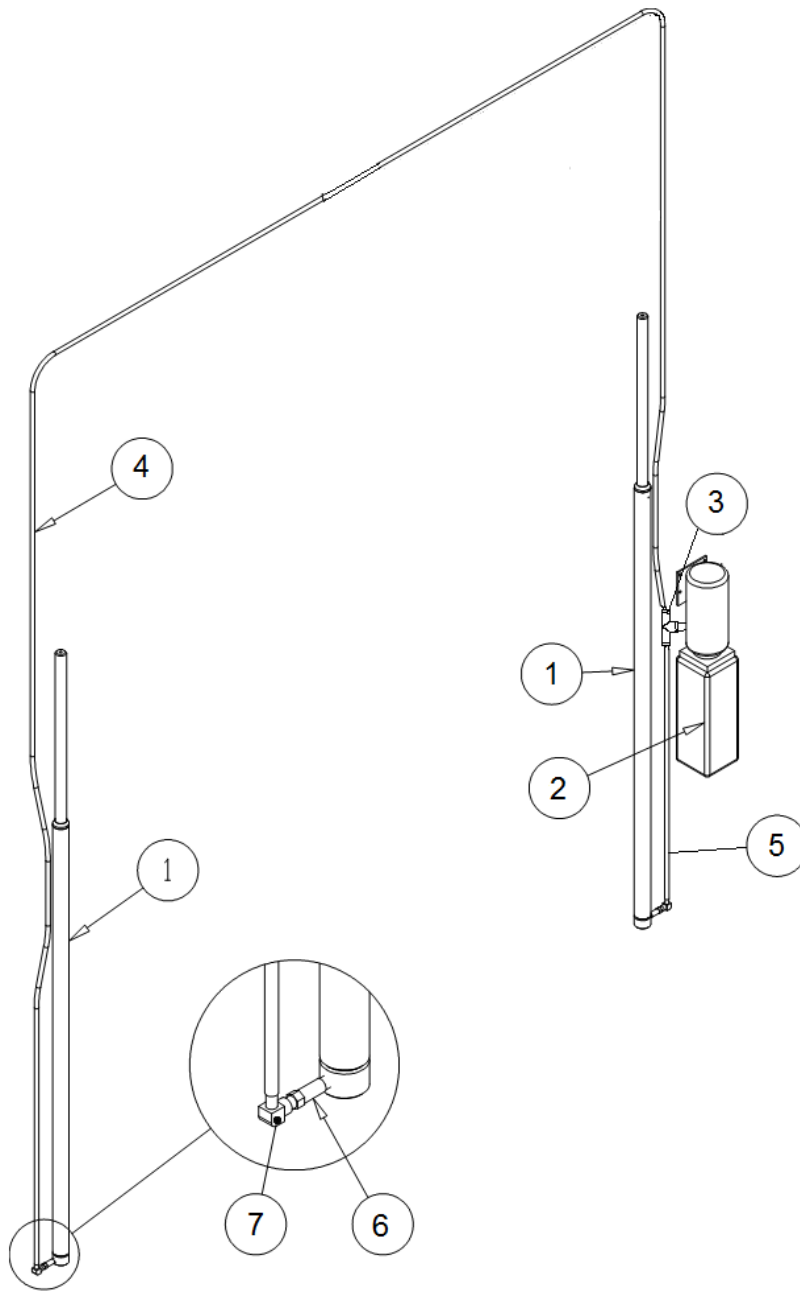

ITEM NO.	PART NUMBER	DESCRIPTION	QTY.
1	42120018	CYLINDER	2
2	32120003	POWER PACK	1
3	3H000016	T FITTING	1
4	12125114	HYDRAULIC HOSE LONG	1
5	12125116	HYDRAULIC HOSE SHORT	1
6	32125109	FLOW RESTRICTOR 3/8 NPT	2
7	3H000008	3/8 NPT - 3/8 GIC 90 ANGLE	2

Diagram #9: SAFETY LOCK COVER INSTALLATION

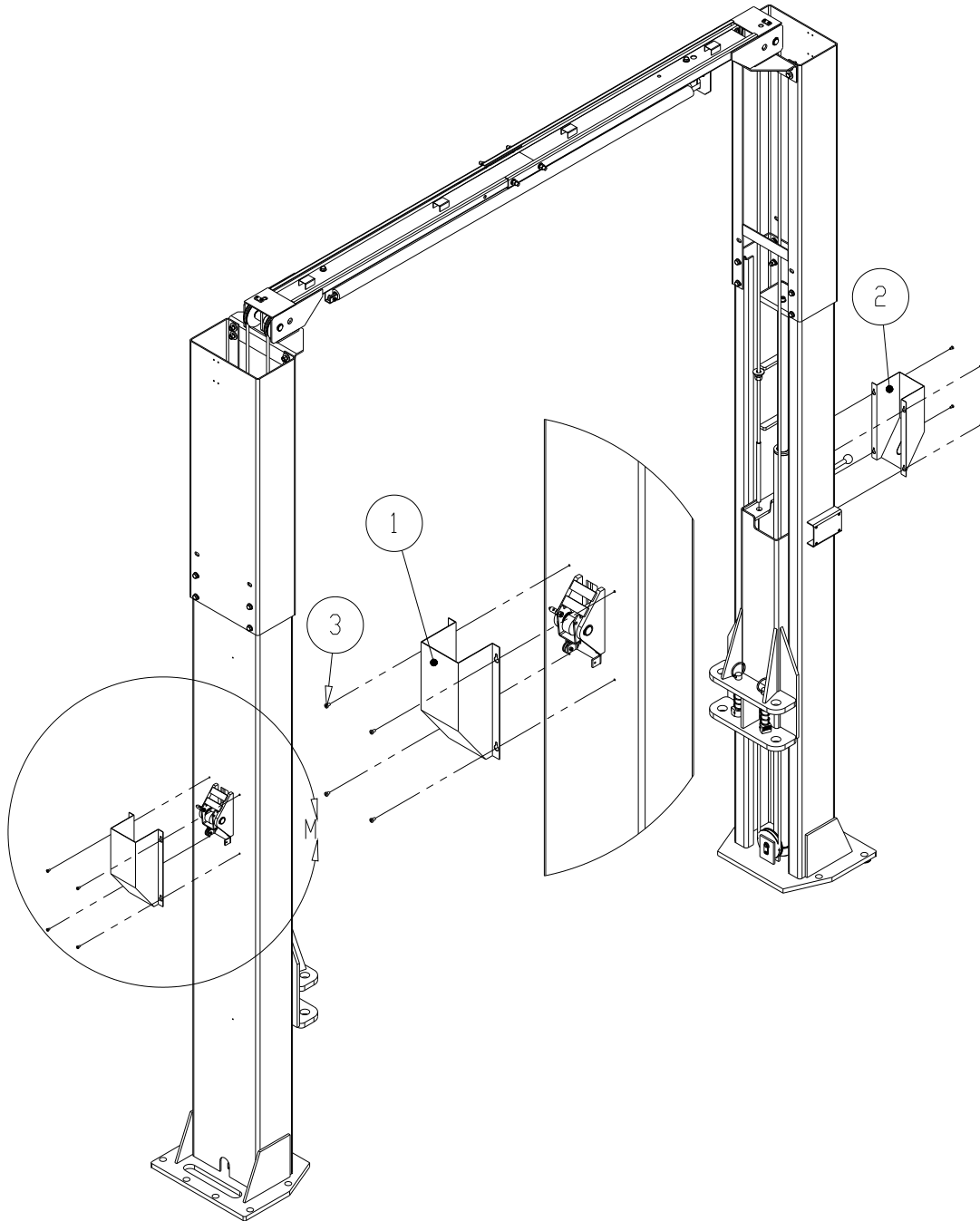

ITEM NO.	PART NUMBER	DESCRIPTION	QTY.
1	12120009	LATCH COVER	1
2	12120027	POWER TOWER LATCH COVER	1
3	3C000060	M6x10 SCREW	8

Diagram#10: Wiring Diagram

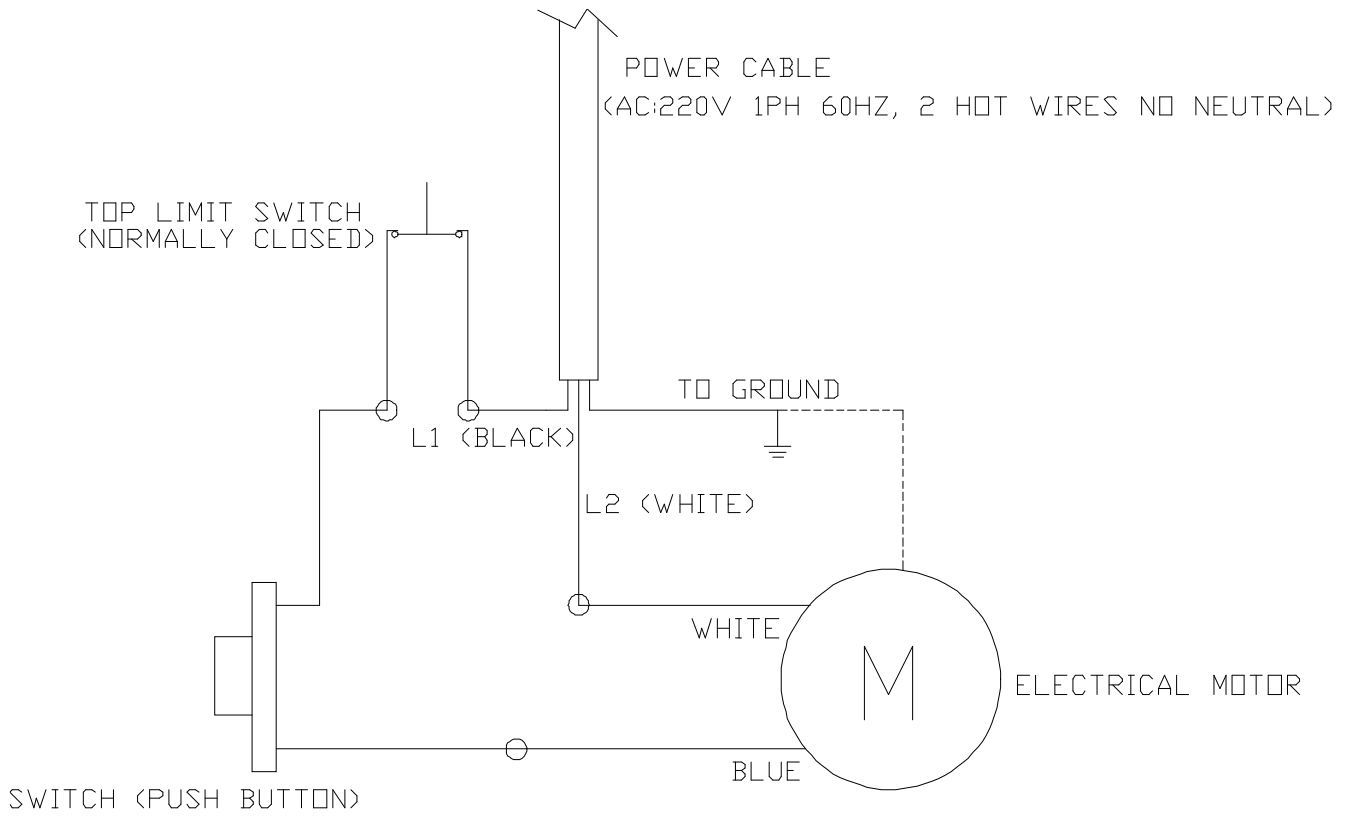
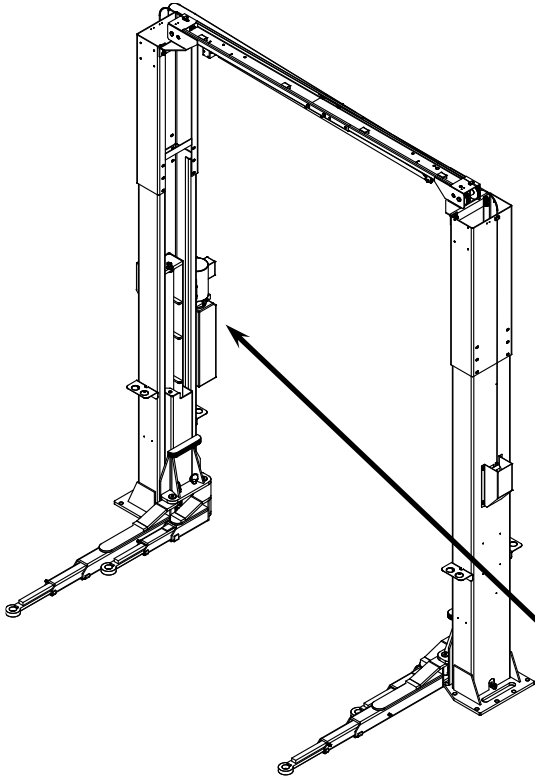

Diagram #11: SAFETY INSTRUCTIONS



Individual Decals to Powerpack Column in clear view of operator

 CAUTION Lift to be used by trained operator only.	 CAUTION Authorized personnel only in lift area.	 WARNING Clear area if vehicle is in danger of falling.	 WARNING Position vehicle with center of gravity midway between adapters.
 CAUTION Use vehicle manufacturer's lift points.	 CAUTION Always use safety stands when removing or installing heavy components.	 WARNING Remain clear of lift when raising or lowering vehicle.	 WARNING Avoid excessive rocking of vehicle while on lift.
 CAUTION Use height extenders when necessary to ensure good contact.	 CAUTION Auxiliary adapters may reduce load capacity.	 WARNING Do not override self-closing lift controls.	 WARNING Keep feet clear of lift while lowering.

The messages and pictographs shown are generic in nature and are meant to generally represent hazards common to all automobiles regardless of specific style. Funding for the development and validation of these labels was provided by the Automotive Lift Institute, PO Box 85 Cortland, NY 13045. Replacement label sets may be obtained from the original lift manufacturer and ALI's member companies. They are protected by copyright. www.autolift.org ©1992 by ALI, Inc. ALIWI101

The messages and pictographs shown are generic in nature and are meant to generally represent hazards common to all automobiles regardless of specific style. Funding for the development and validation of these labels was provided by the Automotive Lift Institute, PO Box 85 Cortland, NY 13045. Replacement label sets may be obtained from the original lift manufacturer and ALI's member companies. They are protected by copyright. www.autolift.org ©1992 by ALI, Inc. ALIWI101

SAFETY INSTRUCTIONS



Read operating and safety manuals before using lift.

SAFETY INSTRUCTIONS

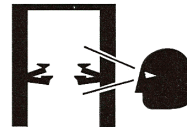

Proper maintenance and inspection is necessary for safe operation.

SAFETY INSTRUCTIONS

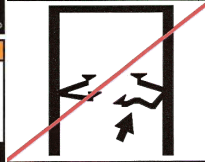

Do not operate a damaged lift.

The messages and pictographs shown are generic in nature and are meant to generally represent hazards common to all automotive lifts regardless of specific style.

Funding for the development and validation of these labels was provided by the Automotive Lift Institute, PO Box 85 Cortland, NY 13045.

Replacement label sets may be obtained from the original lift manufacturer and ALI's member companies. They are protected by copyright.

www.autolift.org
© 1992 by ALI, Inc.

ALIWI101s

COATS

NOTES

Coats company, llc
1601 J.P. Hennessy Drive
Lavergne, tn 37086 usa
1800-688-6359
www.coatscompany.com

COATS