

coats

MINI 30VX

Capacity 6,600LB

Noiselevels 70dB(A)

INSTALLATION MANUAL
OPERATION MANUAL
SERVICE PART MANUAL
MODEL: 4TS6SSOR1



EAC

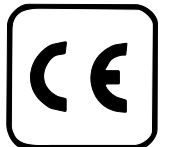
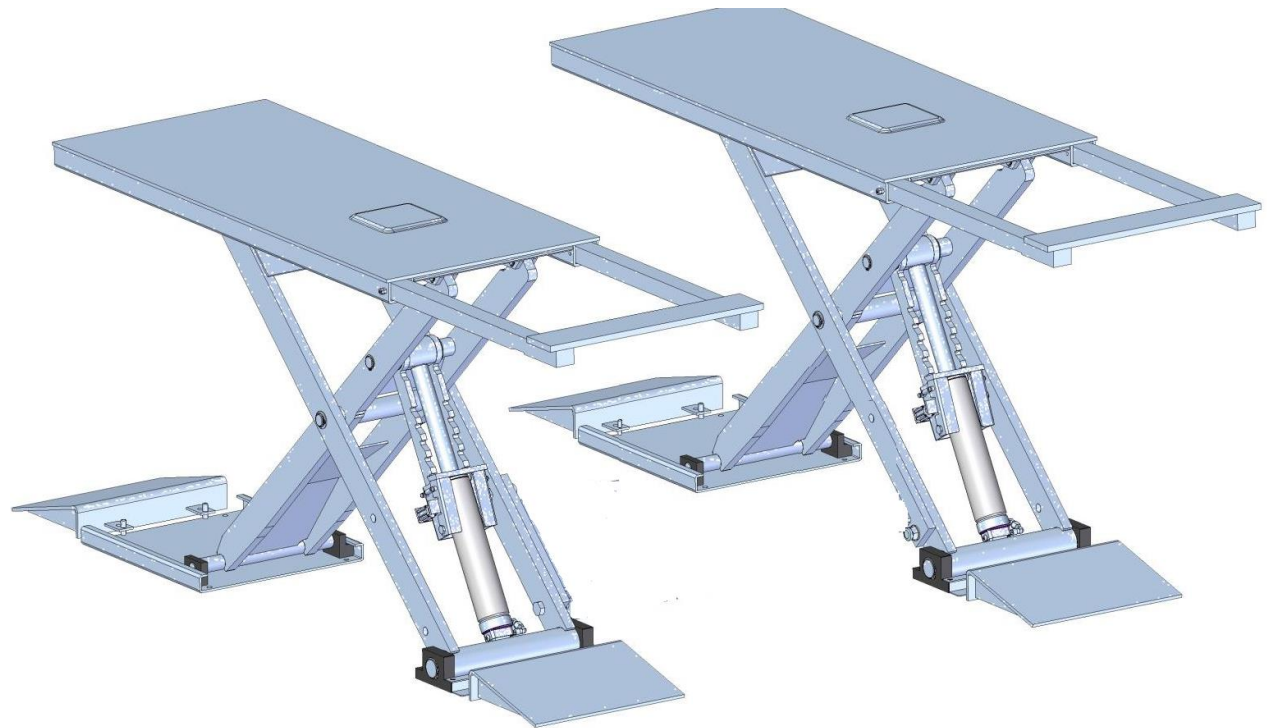

INDEX.....ENGLISH

.....
 1
 2

Symbols used in the manual..... 2

 **1. GENERAL INFORMATION..... 3**

1.1. DECLARATION OF **CE** CONFORMITY 3
 1.2. ASSISTANCE..... 3
 1.3. DESCRIPTION OF PERSONNEL 3

 **2. DESCRIPTION OF THE MACHINE..... 4**

2.1. EXPECTED USE..... 4
 2.2. TECHNICAL DATA 4
 2.3. MAIN PARTS **ERROR! BOOKMARK NOT DEFINED.**
 2.4. OVERALL DIMENSIONS 6
 2.5. LOADING CONDITIONS..... 8

 **3. SAFETY..... 9**

3.1. GENERAL SAFETY REGULATIONS 9
 3.2. PRECAUTION..... 10

 **3.3. IMPROPER USE 11**
 3.4. SAFETY DEVICE FEATURES..... 12
 3.5. STICKERS AND PLATES..... 13

 **4. INSTALLATION 14**

4.1. TRANSPORT AND HANDLING 14
 4.2. PLACE OF INSTALLATION..... 16
 4.3. CONNECTING THE LIFT..... 17
 4.4. CONNECTING THE LIFT'S COMMANDS..... 17

4.4.1. *Hydraulic connections* 17
 4.4.2. *Electric connection* 18
 4.5. FILLING OF THE HYDRAULIC CIRCUIT 20
 4.6. ANCHORAGE CAPSULE INSTALLATION..... 21
 4.7. CHECKS BEFORE USE 22
 4.8. FINAL TESTING..... 23

 **5. USE 5-24**

5.1. OPERATION COMMANDS..... 5-24
 5.2. RESIDUAL RISKS..... 25







 **6. MAINTENANCE..... 26**

6.1. ROUTINE MAINTENANCE 26
 6.2. TABLE ADJUSTMENT PROCEDURES 28
 6.2.1. *Maximum pressure valve calibration*..... 28
 6.2.2. *Parachute valve*..... 29
 6.3. SAFETY MANOEUVRES..... 30
 6.4. ABNORMAL OPERATION 31

7. INSTALLATION REPORT..... 32
8. PERIODIC MAINTENANCE REPORT 35
9. LIFT ILLUSTRATIONS and PARTS LIFT 37



Symbols used in the manual

The signage (ISO) indicated below is used within this manual to focus attention on those operations that must be performed carefully in order to guarantee safety during installation.

	GENERAL DANGER	Indicates that, when performing the operation, great care must be taken to prevent the onset of events that could cause serious injury or damage.
	ELECTRICAL DANGER	Indicates that, when performing the operation, an event (of an electrical nature) could arise leading to injury or damage.
	DANGER OF PINCHING	Indicates that, during installation or transport of system components, suitable lift equipment must be used and utmost attention applied.
	DANGER OF FALLING	Indicates that, during installation, the operator crosses zones where there is high risk of falling; always be particularly careful.
	IMPORTANT	Indicates that the indications or instructions described in the text must be followed to the letter. Non-compliance with the indications can be dangerous for the operator and can damage the system.
	PROHIBITION	Indicates that the specific activity or operating sequence must be avoided

1. GENERAL INFORMATION

1.1. Declaration of $\text{C}\epsilon$ conformity

	SETTORE SOLLEVAMENTO VEICOLI VEHICLE LIFTING DPT. FZ. HABERTEILUNG SECTEUR ELEVATION VEHICULES SECTOR ELEVACION VEHICULOS	O.M.E.R. S.p.A. Cap. Soc. € 1.000.000,00 Int. vers. 30035 MIRANO (VENEZIA) Italy - Via Galileo Galilei, 20 Tel. 041.5700303 - Fax 041.5700273 E-mail: info@omeritf.com - www.omeritf.com REA VE 146912 - Reg. delle Imprese VE n°0073664027 Codice Fiscale e Partita Iva: 00736640277
	DECLARATION OF $\text{C}\epsilon$ CONFORMITY in compliance with annex II of the Machinery Directive 2006/42/CE O.M.E.R. S.p.A. - via G. Galilei, 20 - 30035 Mirano (VE) - ITALY	
HEREBY DECLARES UNDER ITS OWN RESPONSABILITY THAT THE PRODUCT VEHICLE LIFT		
Model:	Serial N° <input type="text"/>	Month/year of manufacture: <input type="text"/>
<input checked="" type="checkbox"/> Complies with Directive 2006/42/CE. <input checked="" type="checkbox"/> Complies with Directive 2006/95/CE (Electric system with low voltage). <input checked="" type="checkbox"/> Complies with the requisites set forth in EEC Directive 2004/109/CE (electromagnetic compatibility directive). <input checked="" type="checkbox"/> Complies with standard UNI EN 1493:2010.		
The technical instalment is deposited by: O.M.E.R. S.p.A., Via Galileo Galilei, 20 - 30035 MIRANO (VENEZIA) Italy Mirano,		
O.M.E.R. S.p.A.		
COD:		

1.2. Assistance

Please use the following contact details for assistance requests:

TEL. +1 (905) 847 1198

FAX. +1 (905) 891 1214

1.3. Description of personnel

TERMS AND DEFINITIONS

- OPERATOR/SPECIALISED TECHNICIAN:
the person(s) appointed to:
 - install,
 - set up,
 - adjust
 - perform maintenance on,
 - clean,
 - repair
 - transport the lift.
 - perform certain maintenance operations that require specific preparation and expertise in the mechanics, electrical, electronic, oil-hydraulic and pneumatic fields.

The specialised technician is aware of any risks present on the machine and the procedures to be followed to avoid damage to his/herself or others during such maintenance operations.

- EXPOSED PERSON: any person wholly or partly in a hazardous area.
- HAZARDOUS OR RISKY AREA: any area inside and/or close to a machine in whose presence an exposed person constitutes a risk for his/her health and safety.
- USER: anyone who buys or possesses the lift in any way (on loan, hire, lease, etc.), with the intention of using it as indicated by the manufacturer.
- MAINTENANCE: all activities, which shall be done to keep the system in efficiency and in good condition.
- DPI: (PPE) Personal protection equipment.



2. DESCRIPTION OF THE MACHINE

Addressees:

- USER;
- OPERATOR / SPECIALISED TECHNICIAN.

2.1. Expected use

The function of the lift is to lift motorized vehicles, which have the distribution of the loading according norms in force.

The vehicle movement has to be done with lift closed.

Accessories shown in the relevant chapter can be used.

2.2. Technical data

TABLE CAPACITY	LB	6,600LB	
MOTOR POWER	KW	2.3	
ELECTRIC POWER SUPPLY	V	230 V 1PH	± 10 %
	Hz	60	± 2 Hz
PNEUMATIC POWER SUPPLY	bar	8	Filtered and lubricated
MAXIMUM PRESSURE OF HYDRAULIC POWER SUPPLY	Psi	4060	
QUANTITY OF OIL	LT	10	
UPSTROKE/DOWNSTROKE TIME	S	20 / 20	
MIN/MAX OPERATING TEMPERATURE	°C	0 ÷ +50	
SOUND EMISSION LEVEL	db(A)	< 80	

2.3. Main Parts

MODEL KEY:

MINI 30VX NTB ABOVE GROUND VERSION (SMOOTH TRAVEL)

N°	DESCRIPTION	30VX
1	Platform	X
2	Internal scissors	X
3	External scissors	X
4	Movable flaps	X
5	Hydraulic cylinder	X
6	Base plate	X
7	Electric box	X
8	Hydraulic unit	X

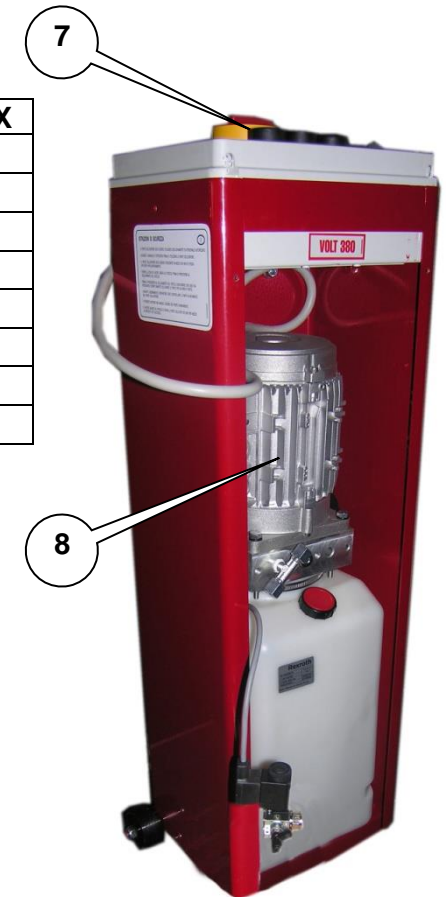

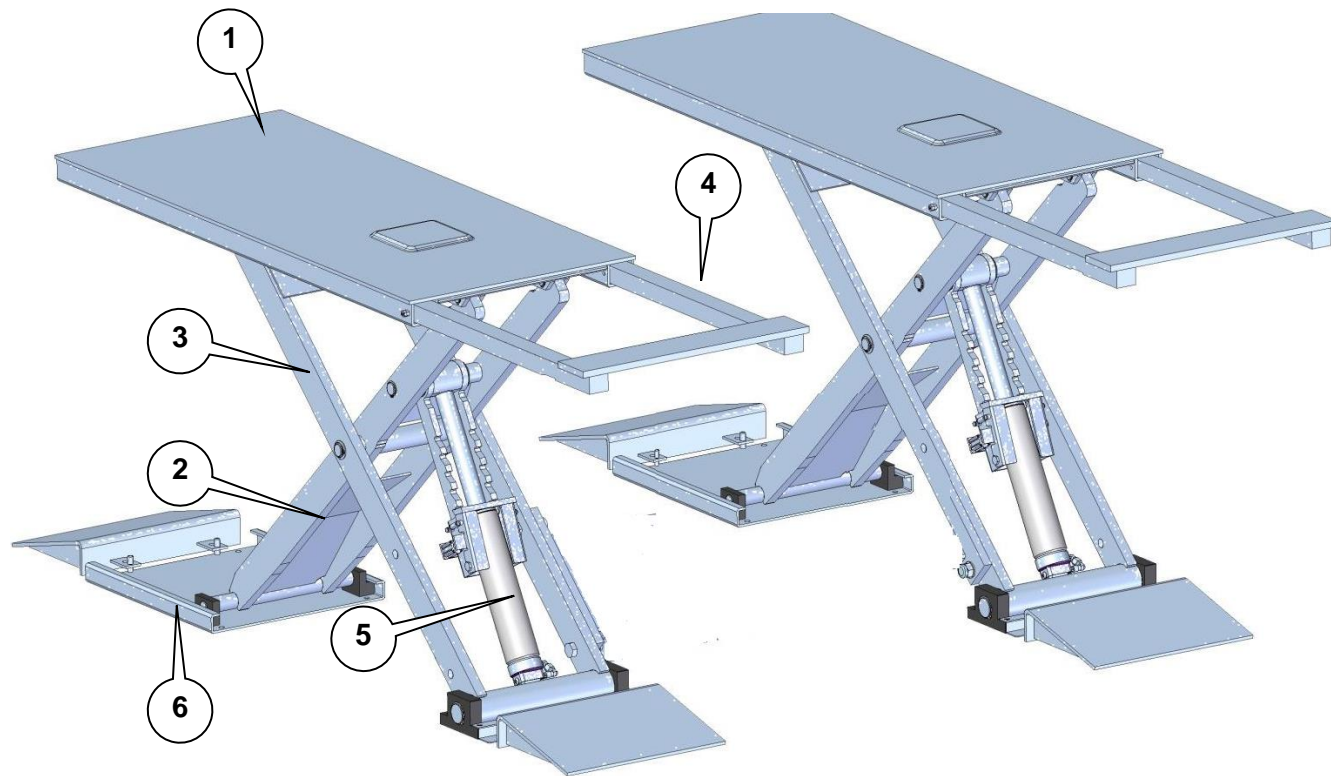

2.4. Overall dimensions

MINI 30VX
ABOVE GROUND

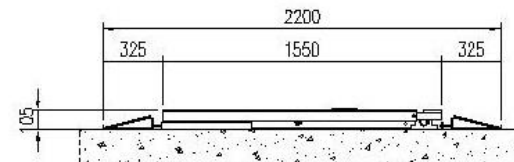
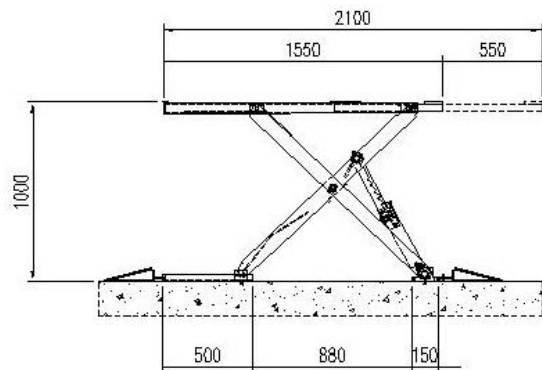

CONTROL PANEL FOR LIFT
INDICATIVE POSITION
CENTRALINA SOLLEVATORE
POSIZIONE INDICATIVA

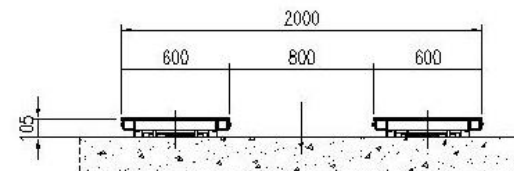
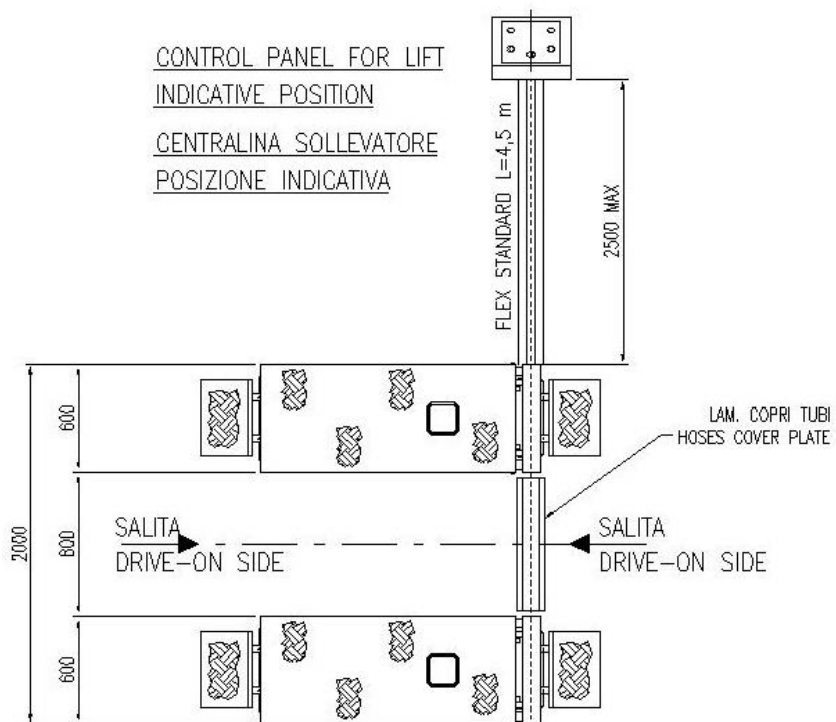

COD. FMINI30VX0010	REV. -
--------------------	--------

**MINI 30VX
FLUSHMOUNT**

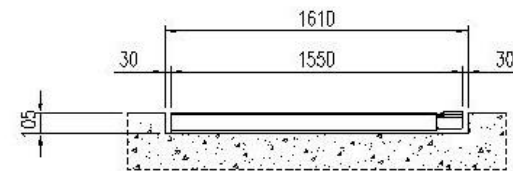
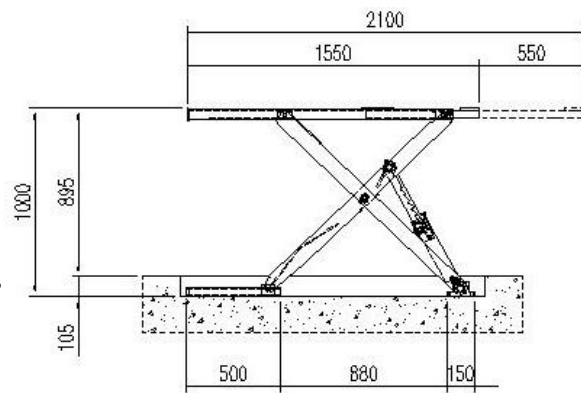

CONTROL PANEL FOR LIFT
INDICATIVE POSITION
CENTRALINA SOLLEVATORE
POSIZIONE INDICATIVA



FLEX STANDARD L=4,5 m

2500 MAX

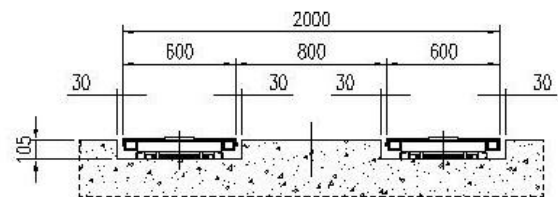

SALITA
DRIVE-ON SIDE

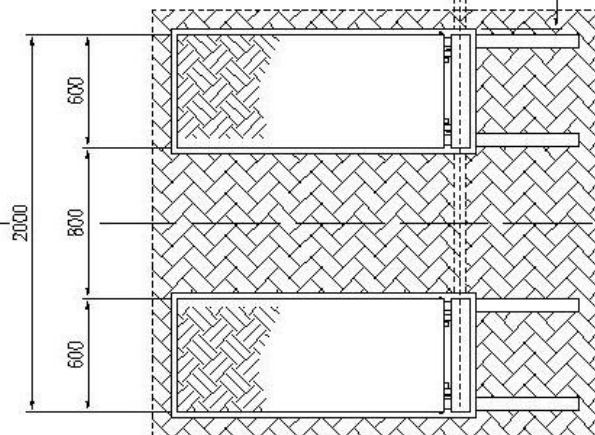

SALITA
DRIVE-ON SIDE

cod. FMINI30VX0050	REV. -
--------------------	-----------

2.5. *Loading conditions*

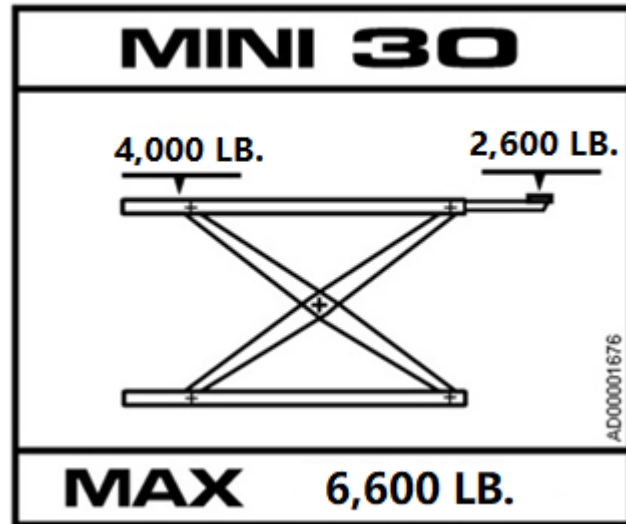

CONTACT CLEARANCE

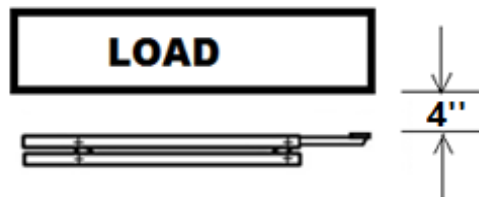

3. SAFETY

Addressees:

- USER;
- OPERATOR / SPECIALISED TECHNICIAN.

3.1. General safety regulations



For instant consultation by the operator, this manual must:

- be kept in a well-known, easily accessible place
- be kept in good condition

Before proceeding with installation and use of the machine, the user must read the manual carefully, especially the safety rules.







The machine should be used by authorised, trained personnel only. The user (owner and/or employee) must make sure that the fitter has provided:

- all accessories
- the spares provided with the lift
- this use and maintenance manual





Use as described in this manual only. Always use the accessories recommended by the manufacturer.



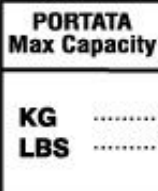

O.M.E.R. S.p.A. declines all responsibility for non-compliance with the indications given in this manual.

The main safety rules are shown below:

	Read all instructions carefully
	Put the main switch to the zero position when the machine is not in use. Never pull the electric cable to remove the plug from the socket.
	To reduce the risk of fires, avoid using the lift close to open drums of inflammable liquid (such as gas oil) and/or in explosive environments.
	Make sure the work area is adequately aired when using internal combustion engines.
	Avoid contact between parts of the body and/or clothing and moving parts.
	Protect the control unit adequately if used outdoors.

3.2. *Precaution*

	<p>When loading the lift never exceed the capacity shown on the ID plate on the lift.</p>
	<p>Never lift people.</p>
	<p>Any modifications to the lift must be authorised by the manufacturer.</p>
	<p>The equipment must be used by specifically trained and authorised personnel only.</p>
	<p>Do not tamper with the lift's upstroke and downstroke speeds, which have been adjusted by OMER during factory tests in compliance with applicable legislation.</p>

	<p>Always check the stability of hoisted vehicle.</p>
	<p>Do not use the lift in the event of hindrances to operation or hazardous conditions.</p>
	<p>Check the lift carefully after long periods of inactivity before putting it back into service.</p>
	<p>The lift comes complete with an instruction manual and warnings designed to last over time. Ask the manufacturer for a replacement immediately if damaged or destroyed.</p>

3.3.



IMPROPER USE

NEVER lift vehicles using equipment other than that envisaged by the manufacturer

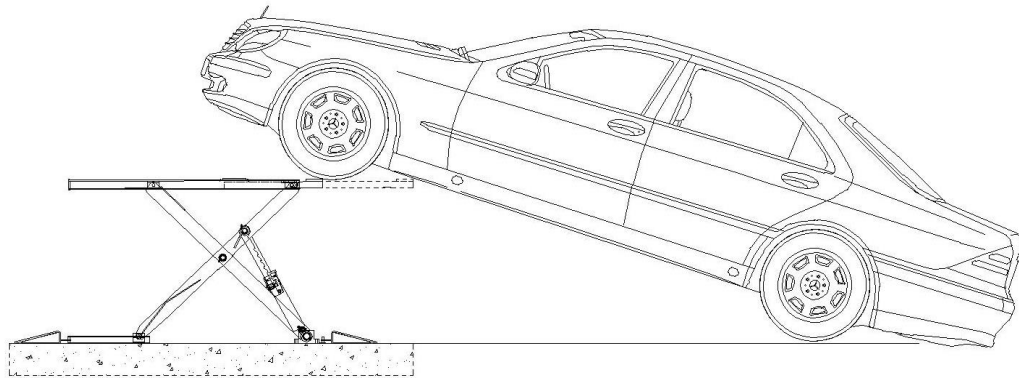
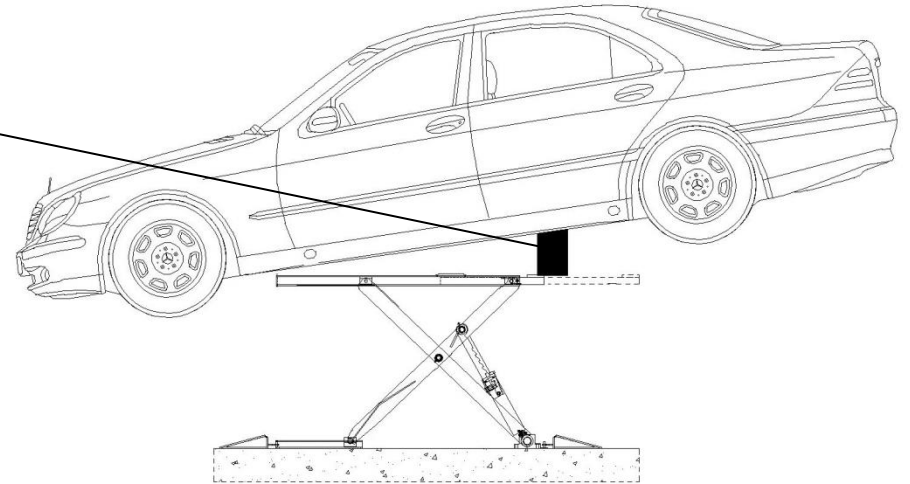

NEVER lift vehicles that are only partially on the lift

3.4. Safety device features

SAFETY DEVICE	COMPOSED OF	POSITION	IN THE EVENT OF ...	EFFECT ON MAIN LIFT
MECHANICAL ANTI-FALL DEVICE	Rack jack	In both hydraulic cylinders of the 2 lifts	Leakage on the hydraulic circuit or breakage of a component	Accidental descent is blocked with a maximum displacement of 100 mm.
HYDRAULIC PARACHUTE DEVICE	Parachute valve	On each hydraulic cylinder of the lift.	Breakage of hoses.	The valve blocks descent when the speed reaches a value preset by the Manufacturer.
SIGNALS	Stickers and plates	See paragraph: <i>Stickers and plates</i>	-	Draw attention to residual risks and precautions for use.

3.5. Stickers and plates

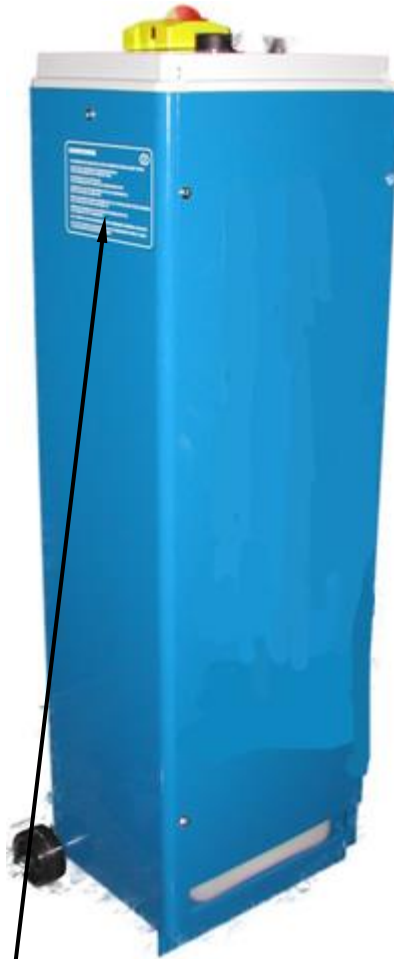

SAFETY RULES (GB)

- THE LIFT MAY BE OPERATED BY AUTHORIZED PERSONNEL ONLY.
- READ THE INSTRUCTION MANUAL CAREFULLY BEFORE OPERATING THE LIFT.
- THE LIFT SHOULD BE POSITIONED SO AS TO AVOID UNINTENTIONAL MOVEMENTS.
- BEFORE OPERATING THE LIFT, MAKE SURE THE WORK AREA IS FREE FROM OBSTACLES.
- BEFORE LIFTING THE VEHICLE, MAKE SURE IT IS CORRECTLY POSITIONED BY SLIGHTLY RAISING THE LIFT.
- WHILE THE LIFT IS IN MOTION, THE OPERATOR SHOULD KEEP MOVING PARTS UNDER OBSERVATION.
- KEEP OUT OF RANGE WHILE THE LIFT IS IN MOTION.
- ACCESS TO THE VEHICLE OR THE RAISED LIFT PLATFORM OTHER THAN BY THE MEANS PROVIDED IS PROHIBITED.

AD00001828

**ATTENZIONE
CAUTION
ACHTUNG
ATTENTION
ATENCIÓN**

(I) TOGLIERE LA TENSIONE PRIMA DI APRIRE IL QUADRO ELETTRICO.
(GB) TURN-OFF THE POWER BEFORE OPENING THE ELECTRIC BOX.
(D) DIE SPANNUNG AUSSCHALTEN BEVOR DEN SCHALTAFEL ZU ÖFFNEN.
(F) COUPER L'ALIMENTATION ELECTRIQUE AVANT D'OUVRIR LE COFFRET.
(E) QUITAR LA CORRIENTE, ANTES DE ABRIR EL CUADRO ELECTRICO.

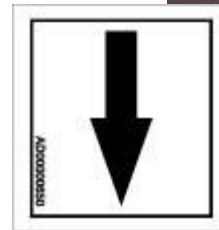
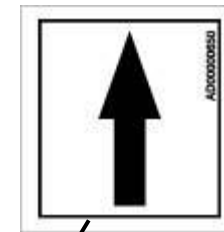

**PREMERE SALITA PER 2 cm PRIMA DI PREMERE DISCESA
PRESS LIFTING FOR 2 cm BEFORE PRESSING LOWERING
DRÜCKEN SIE AUFFAHRT FÜR 2 cm VOR ABFAHRT ZU DRÜCKEN
POUSSER LEVAGE POUR 2 cm AVANT DE POUSSER DESCENTE
EMPUJAR SUBIDA DURANTE 2 cm ANTES DE EMPUJAR BAJADA**

AD00001828



4. INSTALLATION

Addressees:

- OPERATOR / SPECIALISED TECHNICIAN.

4.1. *Transport and handling*

The packaged lift must only be transported using dedicated hoisting equipment with a greater capacity than the lift to be handled.

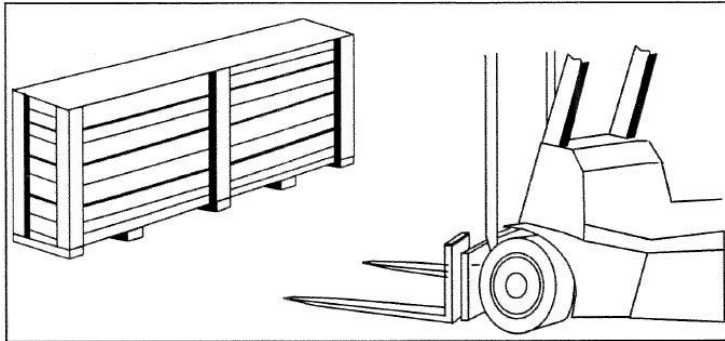

The equipment is wrapped in bubble pack to protect the components wooden crates or pallets are used in special cases.

PROCEED AS FOLLOWS:

- protect the electric control panel from exposure to the elements
- protect against blows and do not use the electronic control panel for hoisting
- protect the corners and ends of the piece to be transported with suitable material (Bubble pack - cardboard).
- harness using dedicated straps

PACKING LIST

VERSION OF LIFT	<p>MINI 30VX is usually sent in 3 packages:</p> <ul style="list-style-type: none">✓ Lift✓ Control unit✓ Accessories <p>The packages may vary according to:</p> <ul style="list-style-type: none">• the size of the lift;• the type of shipment;• the packaging used, subject to customer's request;• the destination country.
MINI 30VX	



DURING TRANSPORT THE CAGE (OR PACKED LIFT) MUST BE SECURED PROPERLY TO PREVENT IT FROM MOVING AROUND ON THE FLOOR OF THE VEHICLE USED TO TRANSPORT IT.

4.2. Place of installation

The free space around the table must satisfy applicable regulations and be no less than 700 mm.

The control unit must be positioned so that the operator has a full view over the lift area.

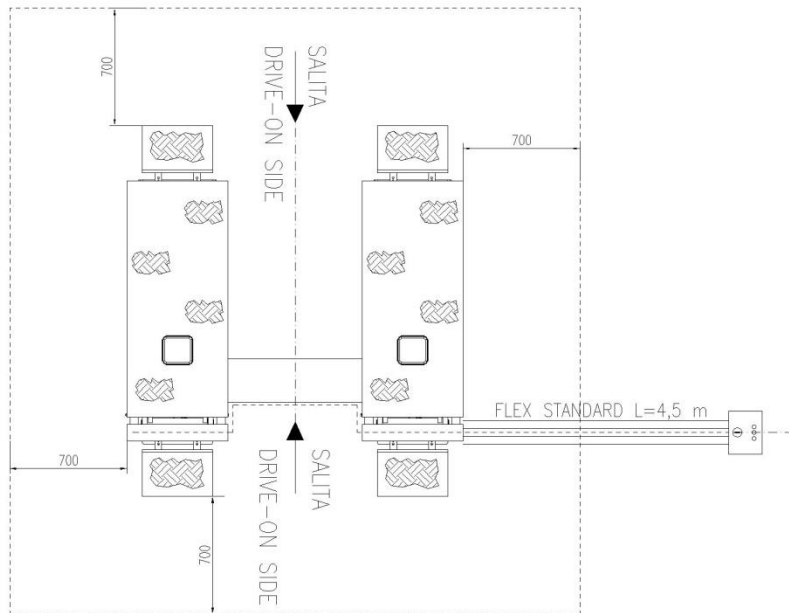

WORK AT A ROOM TEMPERATURE
OF -10° TO 40 ° C.

To install the anchor capsules, the foundation must have the following characteristics:

FOUNDATION	Tamped
THICKNESS OF CONCRETE	≥ 14 cm (5.5 inches)
CONCRETE RESISTANCE CLASS	≥ C 25
IMPROVED ADHERENCE STEEL GIRDERS	Type FeB 44 K
REINFORCEMENT GIRDERS FOR LARGE SURFACES	Electro welded mesh
REINFORCEMENT GIRDERS FOR SMALL SURFACES	Bent irons
FLATNESS	± 1 / 1000

If the floor characteristics are not available, foundations must be provided underneath the lift's clamping holes.

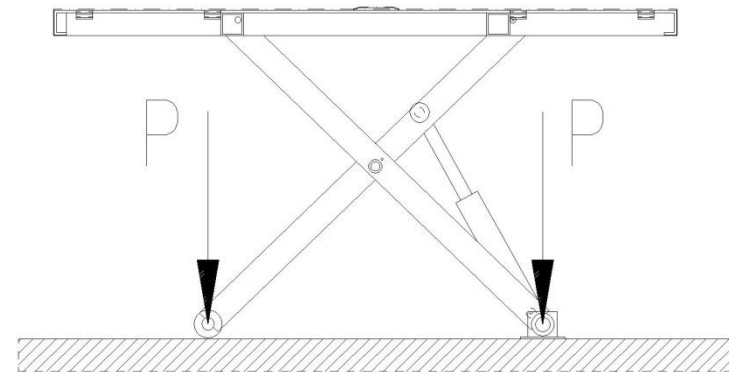

4.3. Connecting the lift

Follow the sequence of operations given below:

1. the case of the MINI 30 , please install the torsion bar
(see paragraph : Installation of torsion bar)
2. connect the hoses provided, which lead out of the control unit with their respective inputs to the lift
(see paragraphs: *Pneumatic, Hydraulic, Electrical connection*).
3. Fasten to the floor with mechanical screw anchors
(see paragraph: *Anchorage capsule installation*).
4. Carry out all due tests before using the lift.
(see paragraphs: *Check and Checks before use*)

The control unit must be positioned:

- so that the operator has a full view over the lift are
- at least one meter by raised vehicle.

4.4. Connecting the lift's commands

4.4.1. Hydraulic connections

- Joint the hoses with the specific joint into the hydraulic unit (see photo)



4.4.1.1. MINI 30 VX

- Screw the hoses from the lift to the hydraulic control unit.



4.4.2. Electric connection

The electric supply system must include:

- a main switch with a circuit breaker;
- fuses or thermal magnet protection suited to the machine's characteristics;
- device against accidental contact, for protection.

The switch must be positioned in the immediate vicinity of the machine in full compliance with local accident prevention regulations.

Power cables must have a suitable section for absorbing current, without deviations for other utilities.

Electric systems must be created according to the state of the art by a qualified electrician who must check the earthing system's efficiency.

The power cable must be locked in the dedicated cable gland and the electric panel must be carefully closed to assure the envisaged IP 54 protection.

Only connect the machine to type approved sockets with an earth cable of proven efficiency.

Periodically have qualified personnel check the correct tightening of the electric cables of the various components.

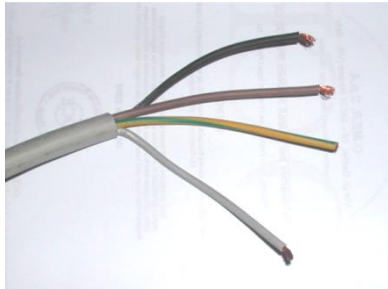

The electric power cable is CEI 20-22 II compliant and has four suitable-section wires.

Attention:

- power the lift's electrics system using a line fitted with a mains switch and without any other junctions.
- The devices fitted to provide protection against short circuits must consider the features of the electrical equipment:

NOMINAL POWER	kW	2.3	
VOLTAGE	V	230	
No. of phases		1	
FREQUENCY	Hz	60	
NOMINAL CURRENT	A	9,5	
PICKUP CURRENT	A	38	
	FUSE (DELAYED)	A	20
	FUSE (FAST)	A	25

Warnings for the installation of electric cables between the control unit and lift:

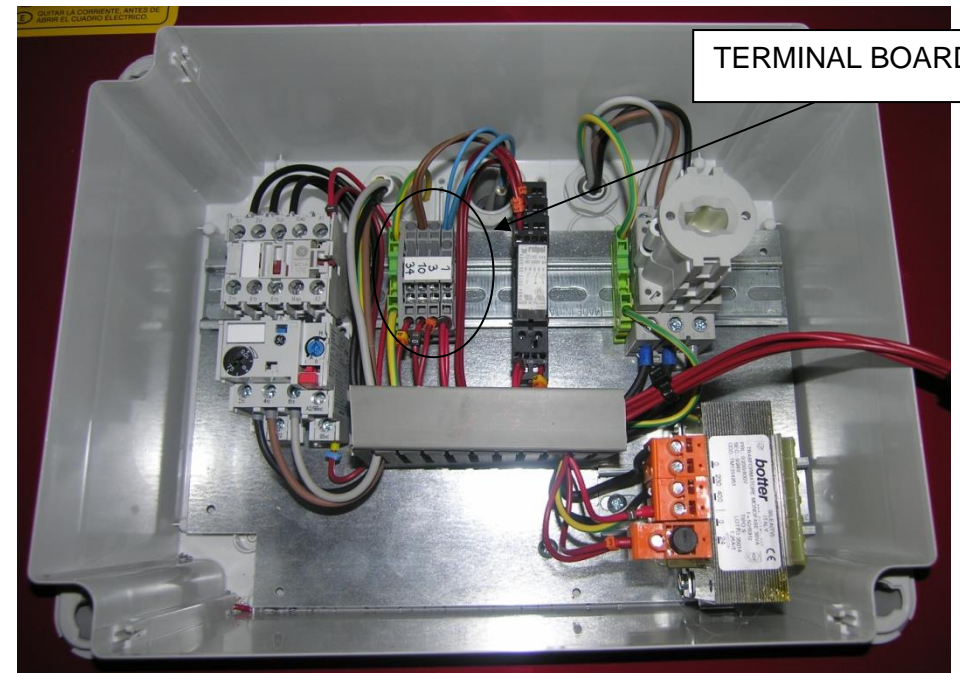

4.5. Filling of the hydraulic circuit

ONLY IN THE CASE OF MINI 30VX

1. Fill the oil tank
2. Turn the taps on
3. Push button PS till max height of the lift.
4. Push button PD till the lift gets to ground level and keep them pushed for 10 seconds more to allow air comes out.
5. Repeat points 3-4 for 2 or 3 times.
6. Push button PS
7. till max height of the lift; keep pushing till the motor goes under stress.
8. Turn the taps off

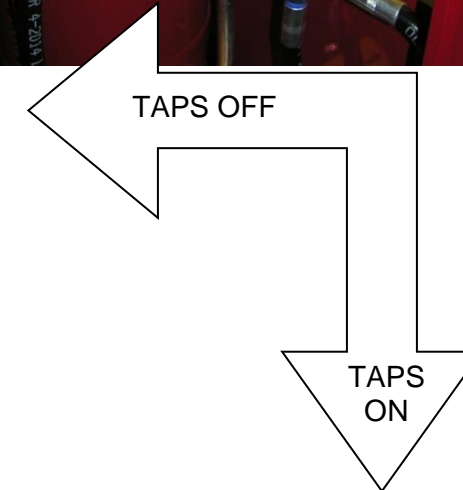
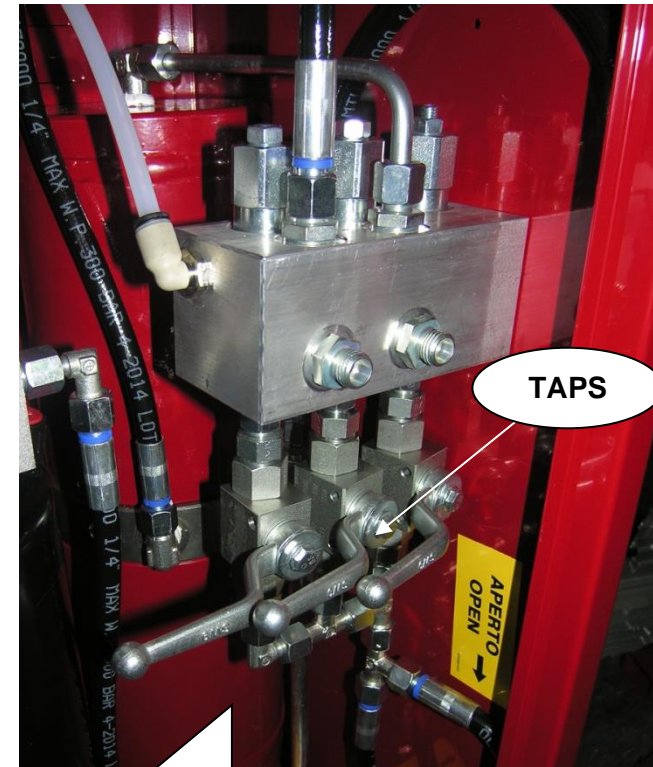

4.6. Anchorage capsule installation

1. Drill hole;
2. Clean the inside of the hole;
3. Insert anchorage capsule into the hole and hammer until it reaches the end;
4. Tighten the pin with a wrench.

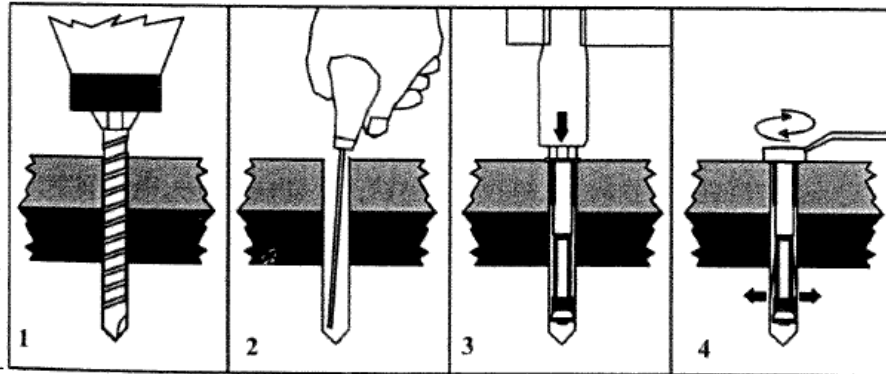

TYPE OF ANCHOR CAPSULE			
DRILL SIZE	A	in	3/8"
INSTALLATION TORQUE	B	ft.lb	30
NOMINAL EMBEDMENT	C	in	2-3/8"
THREAD LENGTH	D	in	2/1/2"
NUMBER OF PINS		No.	16
START TWISTING MOMENT			To be agreed with manufacturer

Choosing pin length on untiled floor.

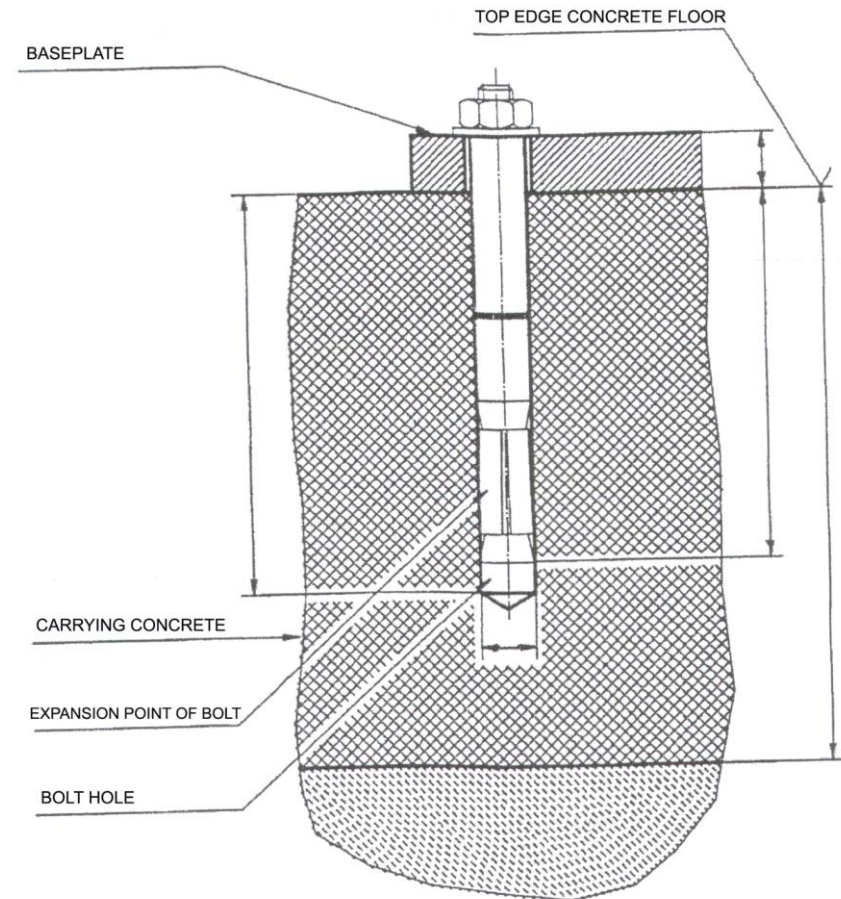

4.7. Checks before use

Having completed installation of the table, the following tests must be performed before it can be used for work:

	TESTS	STANDARDS	
1	Table levelling using spirit level.	Max 0.5 mm per meter.	<input type="checkbox"/>
2	Sturdiness of anchors fastening to the floor.	Tightening torque (50 Nm)	<input type="checkbox"/>
3	Pneumatic connections.	Diagram (see: <i>Pneumatic diagram paragraph</i>)	<input type="checkbox"/>
		Air leakage	<input type="checkbox"/>
4	Hydraulic connections.	Diagram (see: <i>Hydraulic Diagram paragraph</i>)	<input type="checkbox"/>
		Oil leakage	<input type="checkbox"/>
		Pressure	<input type="checkbox"/>
5	Wiring. connections.	Diagram (see: <i>Wiring Diagram</i>)	<input type="checkbox"/>
6	Safety devices.	(See: <i>Safety device features paragraph</i>)	<input type="checkbox"/>
7	The compressed air system must be powered by filtered and lubricated air	Presence of a filtering system.	<input type="checkbox"/>
8	Oil level.	Oil level rod	<input type="checkbox"/>
9	Direction of rotation of motor.	Arrow on motor	<input type="checkbox"/>
10	Plant cable and piping protection.	Cable and pipe runs provided.	<input type="checkbox"/>
11	Load vehicles with suitable dimension, in agreement with the features of the lift.	Loading conditions (see paragraph: <i>Loading conditions</i>)	<input type="checkbox"/>
12	Never load vehicles weighing more than the lift's nominal capacity.	Capacity indicated on plate.	<input type="checkbox"/>

4.8. ***Final testing***

The static and dynamic load tests with overloads are performed at the Manufacturer's premises.

The user may perform nominal load tests (with a $\pm 10\%$ tolerance admitted for maximum valve calibration) with distribution of the loads as described in the *Loading conditions* paragraph of the installation, use and maintenance manual.

Tests can be carried out with the following "overloading factors"

DINAMIC TEST	overload	100%
--------------	----------	------

With loading distributed according the foreseen scheme of the machine in the charter "*Loading conditions*".

To test the unit, the maximum valve calibration pressure must be increased by approximately 15%, checking the value on a manometer (not supplied).



5. USE





Adressees:

- USER;
- OPERATOR / SPECIALISED TECHNICIAN.

5.1. Operation commands.

I	SYSTEM MAIN SWITCH
PS	TABLE UP BUTTON By pressing the button PS , the lift starts the lifting.
PD	TABLE DOWN BUTTON:  PRESS LIFTING FOR 2 cm BEFORE PRESSING LOWERING By pressing the button PD , the lift starts the lowering and the buzzer sounds (BZ)

5.2. Residual risks

	HAZARD	WHO	CONDITION	RISK
	PIPE BREAKING	Maintenance technician	MAINTENANCE	Contact with squirts of pressurised oil
	AIR ELIMINATION FROM CYLINDERS			
	PIPES LOOSENING			
	ELECTRIC SHOCK	Maintenance technician	MAINTENANCE	Contact with live components
	SHEARING	Maintenance technician	MAINTENANCE	Shearing of hands and feet with lift is in movement.
	TIPPING OVER OF THE LOAD	Maintenance technician	MAINTENANCE	During manual lowering, check that the load moves smoothly, without being thrown out of balance. Operate the valves so that the bridge is realigned step by step.
	REDUCED VISIBILITY	Operator	OPERATING	Possible third-party damage



6. MAINTENANCE

Addressees:

- USER;
- OPERATOR / SPECIALISED TECHNICIAN.



The lift organs, control and safety devices should be checked periodically by the user to assure ongoing efficiency.
All routine maintenance operation should be performed by trained staff operating in full safety.

6.1. Routine maintenance

We recommend the following ordinary routine maintenance operations

	WHERE	WHAT	MACHINE STATUS	HOW	TYPE OF GREASE	TYPE OF LUBRICANT
80 h	UNDER PLATFORM	SLIDERS	OFF	GREASE	MOLYCOTE G-4700	
80 h	STRUCTURE	PINS AND SUPPORTS	OFF	LUBRICATE GREASE	MOLYCOTE G-4700	
80 h	HYDRAULIC CIRCUIT	CYLINDER - TUBE UNIONS	IN MOTION	VISUAL INSPECTION		
12 months	HYDRAULIC UNIT	TANK + FILTER	OFF	CLEAN		
12 months	HYDRAULIC UNIT	TANK	OFF	OIL CHANGE		AGIP LH 46 ESSO OSO H 46
12 months	STRUCTURE	BUSHES	OFF	CHECK OF THE WEAR		

Periodically check the electrical safety devices and report any faults to the Service Centre.

LUBRICATION POINTS (repeat symmetrically)

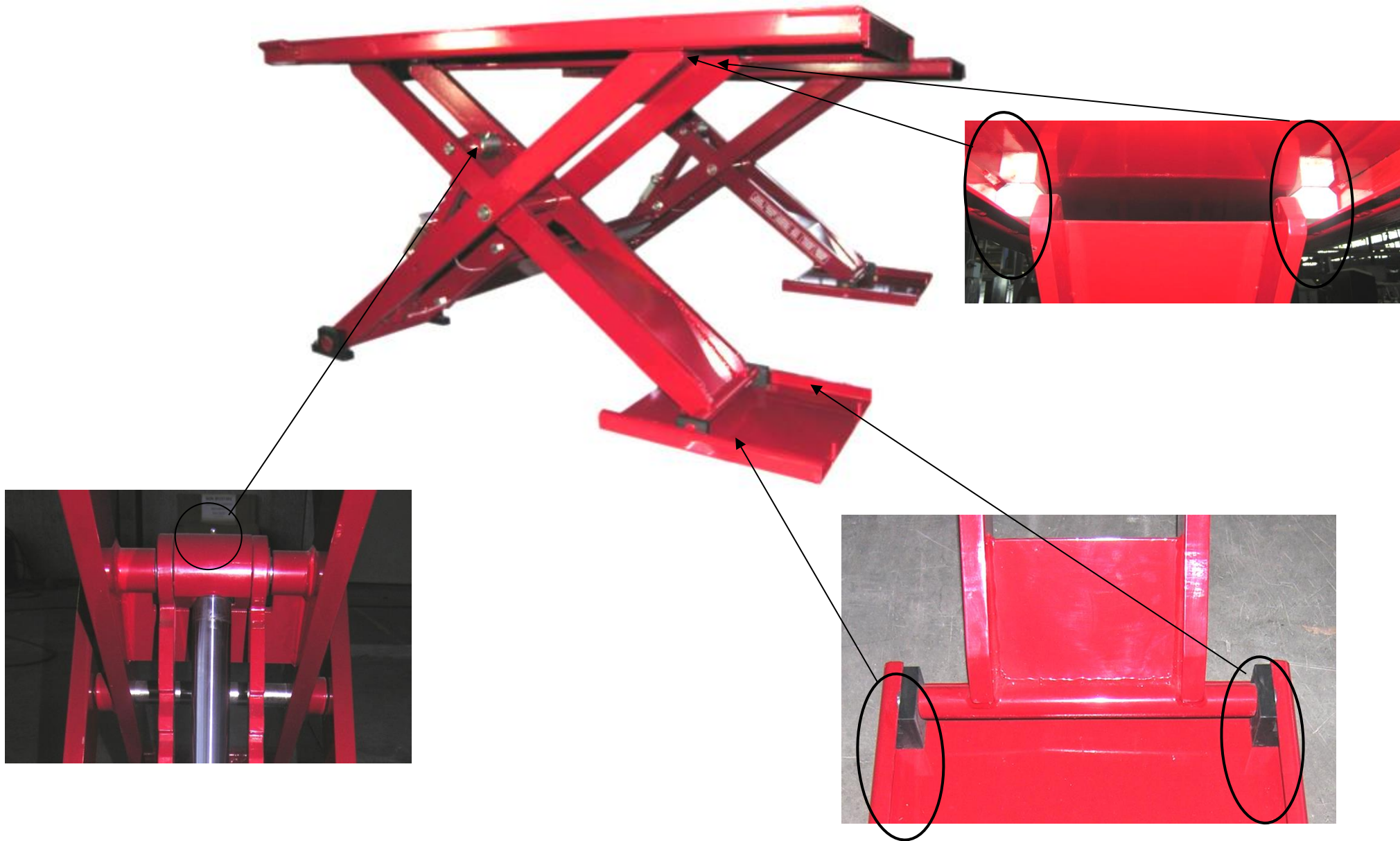

6.2. *Table adjustment procedures*

6.2.1. **Maximum pressure valve calibration**



The calibration of the valve must be executed by specialized people and authorized by the manufacturer. After the calibration the valve must be sealed for example with sealing wax.

- 1) Take the table to maximum height.
- 2) Connect a pressure gauge in line with one of the 2 tubes.
- 3) Loosen the nut by turning two revolutions anticlockwise (A)
- 4) Keeping the up command pressed, check the pressure on the pressure gauge.
- 5) Adjust pressure with a proper key (screwdriver or wrench):
Turn clockwise to increase calibration pressure
Turn anticlockwise to reduce calibration pressure
- 6) When the pressure is equal to P, fix the loosened nut at point 3 and reset everything

PRESSURE	P	Psi	4060
----------	---	-----	------

MINI 30 VX

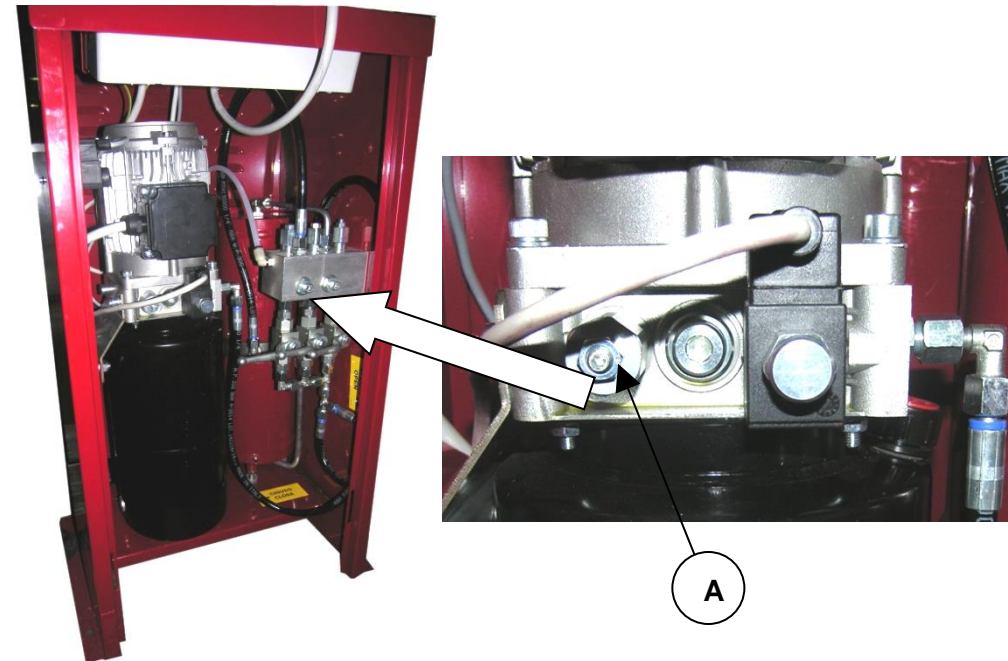

6.2.2. Parachute valve



The calibration of the valve must be executed by specialized people and authorized by the manufacturer.

THE CALIBRATION DISTANCES MUST BE ESTABLISHED BY THE MANUFACTURER.

1. Remove the valve (1) on the bottom of the piston using the key provided (2)
2. Loosen the washer and lock nut (3) beneath the valve.
3. Move the plate of the valve (4) closer or further away as desired, checking the height with the dedicated thickness gauge (5).
4. Reassemble and test.

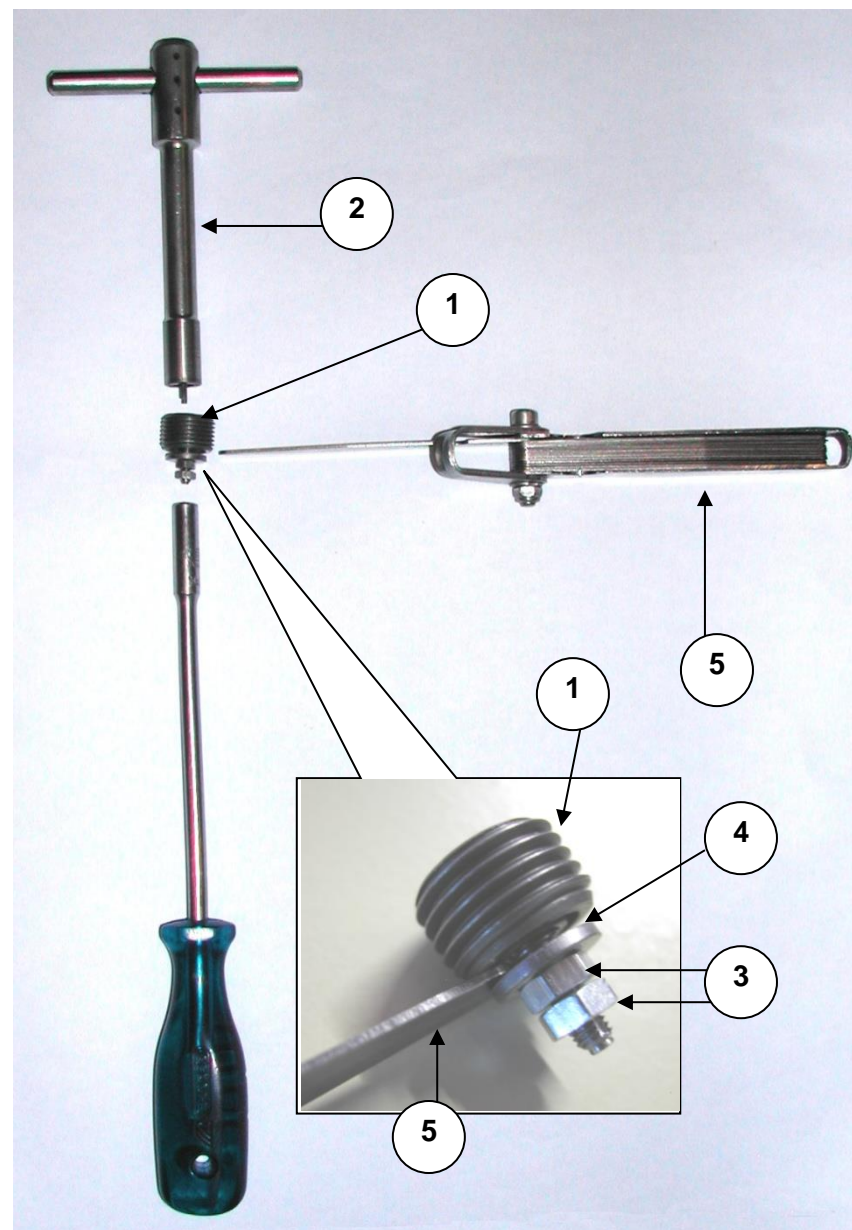
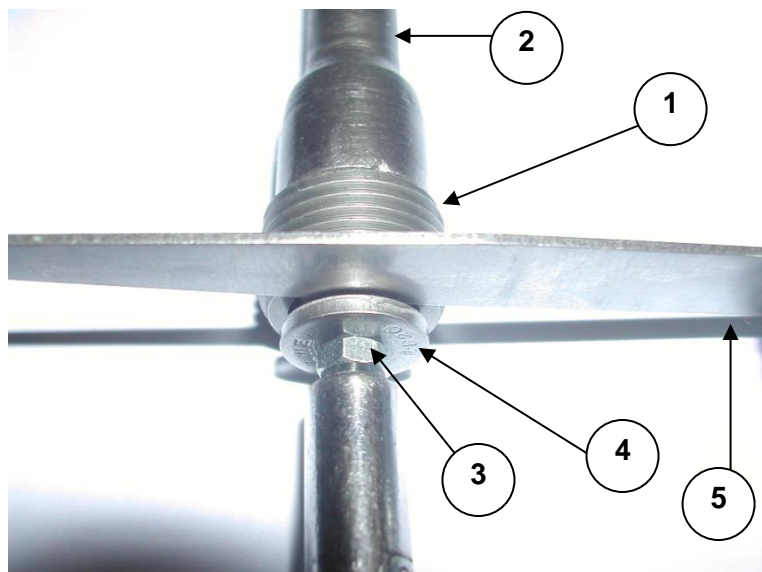

6.3. Safety manoeuvres

MANUAL DOWNSTROKE MANOEUVRE WITH HAND PUMP (accessory available on request)



Operations to be performed to lower raised platform with vehicle on in the case of a blackout:

- unscrew the lock nut on valve EV1, fully unscrew the knurled pin (see photograph);
- pump until the safety jacks move away from the block position;
- activate jack opening using the dedicated manual valve on solenoid valve EV2 (turn screw **A** through 90°);
- allow the table to lower;
- to restore tighten the knurled pin of EV1

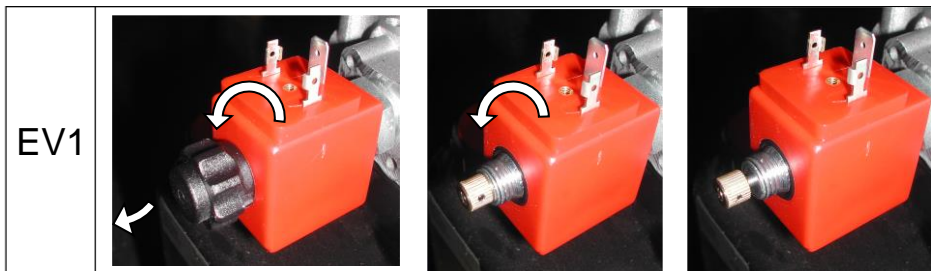

MINI 30 VX

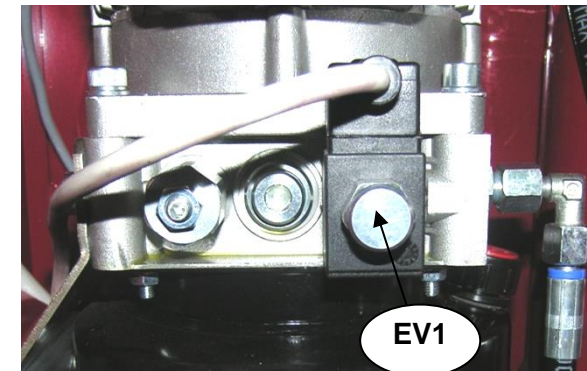
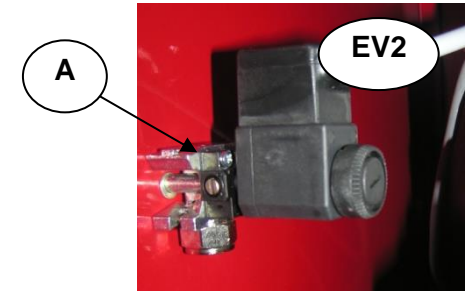

6.4. *Abnormal operation*

WHAT HAPPENS	WHERE	CHECK
The lift does not rise and the motor does not start	<ul style="list-style-type: none"> a. FUSES b. THERMAL RELAY c. TRANSFORMER d. MOTOR e. CONTACTOR 	<ul style="list-style-type: none"> a.1. line fuse blown. a.2. 24-volt fuse blown. b.1. thermal relay tripped, re-cock. c.1. transformer burnt out, does not emit 24 volt. d.1. motor short-circuited or burnt out. e.1. contactor C1 burnt out
The lift does not rise and the motor starts.	<ul style="list-style-type: none"> a. HYDRAULIC PUMP b. DISCHARGE VALVE c. LIMIT VALVE d. MOTOR 	<ul style="list-style-type: none"> a.1. o-ring seal broken. a.2. key broken. a.3. aspiration tube broken. a.4. clamping screws loose. a.5. check oil leakage. a.6. check the pressure value b.1. EV1 remains open. c.1. limit valve broken. d.1. Check that the motor turns in the direction shown by the arrow.
The lift does not lower and the pressure is normal.	<ul style="list-style-type: none"> a. TRANSFORMER b. HYDRAULIC VALVE c. ELECTRIC VALVE d. MECHANICAL SAFETY DEVICES 	<ul style="list-style-type: none"> a.1. transformer burnt out, does not emit 24 volt. b.1. EV1 blocked. b.2. check the parachute valves on the bottom of the dual effect cylinders. c.1. EV1 24 V coil burnt out. d.1. mechanical safety devices mechanically blocked.
Metallic noise	a. BUSHING	a.1. bushing wear
Raising intermittently	a. PINS	a.1. pins damage

7. INSTALLATION REPORT

Model: MINI 30VX

Serial no.:

Installation date:

Control operations to be performed by the skilled/authorized technician in the presence of the user		Reference chapter	Control unit	Main lift	Auxiliary lift	Shunting box/lift	Power supply/lift	Pit	Control performed
1	Integrity of the various lift parts	2.2	◆	◆	◆	◆			□
2	Presence of ID label and stickers	3.4	◆	◆	◆				□
3	For EMBEDDED lifts: - diameter of the PVC pipe (pipe and cable duct) - pit dimensions - presence of a drain	2.3						◆	□
4	Minimum distance of 27 ½ inches between fixed parts of the installation site and mobile parts of the lift	4.2	◆	◆	◆				□
5	Position of control unit (visibility for operator)	4.2	◆						□
6	Power supply voltage	4.4.3					◆		□
7	Type of electric power supply cables	4.4.3					◆		□
8	Electrical protection	4.4.3	◆				◆		□
9	Pneumatic power supply line pressure	2.1	◆				◆		□
10	Diameter of pneumatic power supply pipes	4.4.2	◆				◆		□
12	Sealing of pneumatic circuit	4.4.2	◆	◆	◆	◆	◆		□
13	Oil level in hydraulic circuit	2.1	◆						□
14	Sealing of hydraulic circuit	4.4.1	◆	◆	◆				□
15	Functioning of the controls	5.1	◆						□
16	Greasing of guides	6.3		◆	◆				□
17	Synchronous function of mechanical safety devices	6.2.2.1		◆					□
18	Condition of hydraulic hoses, pneumatic hoses and electrical cables	4.4	◆	◆	◆	◆			□
19	Lift levelling	4.5		◆	◆				□

Control operations to be performed by the skilled/authorized technician in the presence of the user		Reference chapter	Control unit	Main lift	Auxiliary lift	Shunting box/lift	Power supply/lift	Pit	Control performed
20	Stop the main lift at 20 inches from the ground	3.3		◆					▣
22	Stop if the brace misalignment exceeds 50 mm	6.4.2		◆	◆				▣
23	Acoustic warning system function (beeper)	6.4.3	◆						▣
24	Hand pump function	6.5	◆						▣
25	Installation zone cleaning	4.2	◆	◆	◆	◆		◆	▣
26	Lifting of one or more vehicles	2.4		◆	◆				▣
27	Training for use and presentation of the instructions	6	◆	◆	◆				▣
28	Training for maintenance (lubrication...)	6	◆	◆	◆	◆		◆	▣
29	Storing of the instructions	6	◆						▣

Any comments are listed in the Technical report - The user must report these notes in the Safety Logbook.

Authorized technician (company name, address, telephone no.)		Customer (company name, address, telephone no.)	
Name of technician	Signature of technician		

8. PERIODIC MAINTENANCE REPORT

Model: MINI 30 VX

Serial no.:

Installation date:

Control operations to be performed by the skilled/authorized technician in the presence of the user		Reference chapter	Control unit	Main lift	Auxiliary lift	Shunting box/lift	Power supply/lift	Pit	Control performed					
									1	2	3	4	5	
									1	Integrity of the various lift parts	2.2	◆	◆	◆
2	Presence of ID label and stickers	3.4	◆	◆	◆									
3	For EMBEDDED lifts: - diameter of the PVC pipe (pipe and cable duct) - pit dimensions - presence of a drain	2.3						◆						
4	Minimum distance of 27 ½ inches between fixed parts of the installation site and mobile parts of the lift	4.2	◆	◆	◆									
5	Position of control unit (visibility for operator)	4.2	◆											
6	Power supply voltage	4.4.3					◆							
7	Type of electric power supply cables	4.4.3					◆							
8	Electrical protection	4.4.3	◆				◆							
9	Pneumatic power supply line pressure	2.1	◆				◆							
10	Diameter of pneumatic power supply pipes	4.4.2	◆				◆							
12	Sealing of pneumatic circuit	4.4.2	◆	◆	◆	◆	◆							
13	Oil level in hydraulic circuit	2.1	◆											
14	Sealing of hydraulic circuit	4.4.1	◆	◆	◆									
15	Functioning of the controls	5.1	◆											
16	Greasing of guides	6.3		◆	◆									
17	Synchronous function of mechanical safety devices	6.2.2.1		◆										
18	Condition of hydraulic hoses, pneumatic hoses and electrical cables	4.4	◆	◆	◆	◆								
19	Lift levelling	4.5		◆	◆									

Control operations to be performed by the skilled/authorized technician in the presence of the user		Reference chapter	Control unit	Main lift	Auxiliary lift	Shunting box/lift	Power supply/lift	Pit	Control performed					
									1	2	3	4	5	
20	Stop the main lift at 20 inches from the ground	3.3		◆										
22	Stop if the brace misalignment exceeds 50 mm	6.4.2		◆	◆									
23	Acoustic warning system function (beeper)	6.4.3	◆											
24	Hand pump function	6.5	◆											
25	Installation zone cleaning	4.2	◆	◆	◆	◆		◆						
26	Lifting of one or more vehicles	2.4		◆	◆									
27	Training for use and presentation of the instructions	6	◆	◆	◆									
28	Training for maintenance (lubrication...)	6	◆	◆	◆	◆		◆						
29	Storing of the instructions	6	◆											

Any comments are listed in the Technical report - The user must report these notes on the Safety Logbook.

	1	2	3	4	5
Company name of Authorized technician					
Technician's name and signature					
Date of inspection					

16. LIFT ILLUSTRATIONS and PARTS LIST

TABLE 1A COMPRESSED AIR CIRCUIT DIAGRAM

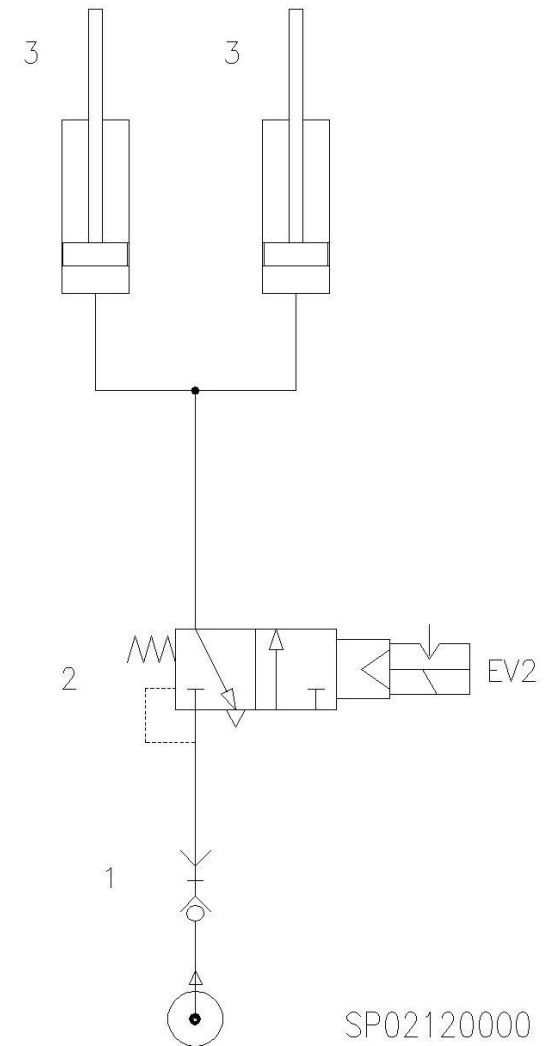

SP02120000

TABLE

1b

COMPRESSED AIR SYSTEM

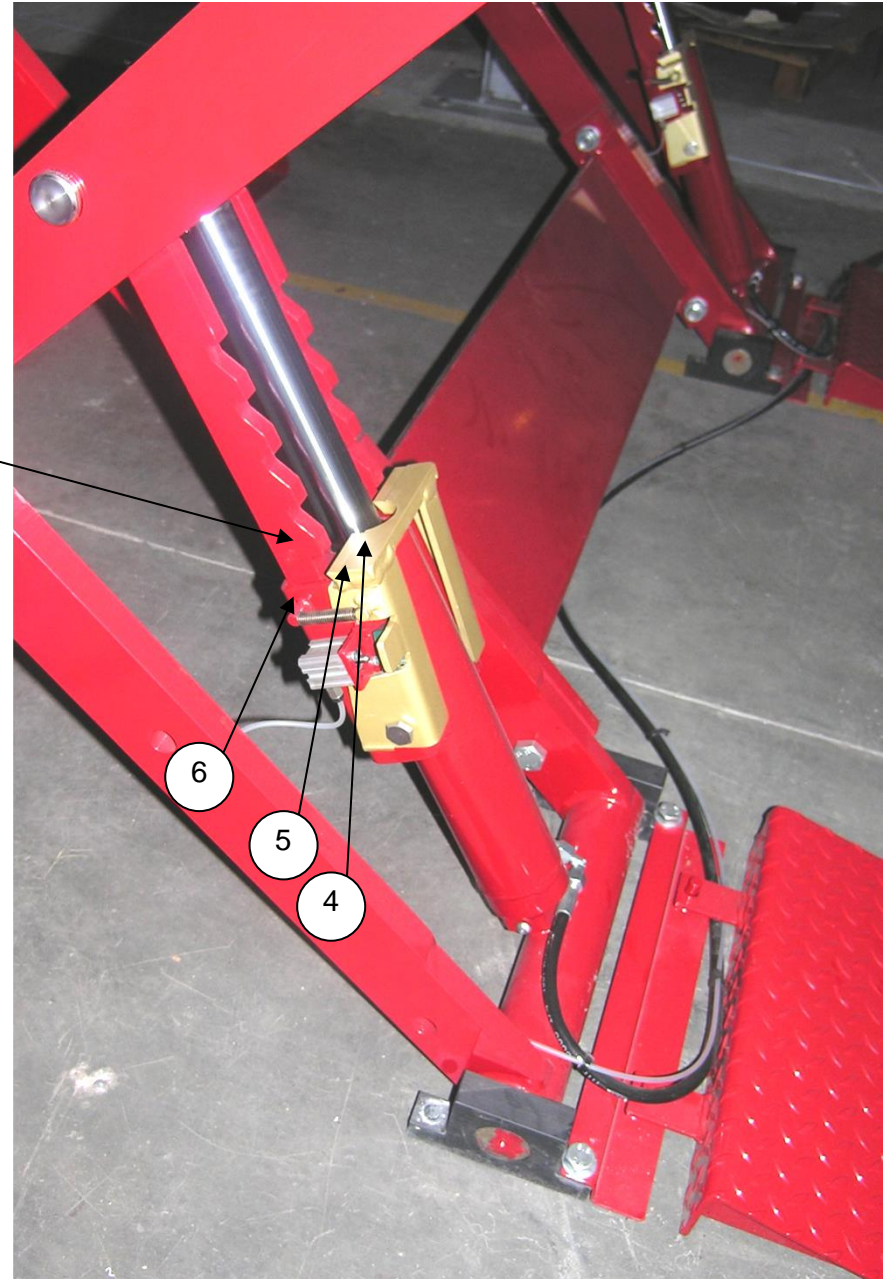
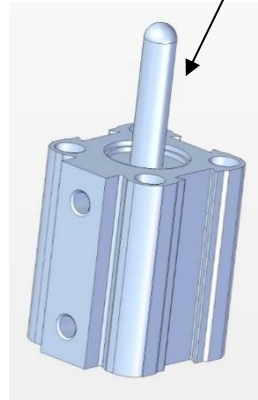

Ref.	Abbr.	Description	Type	Qty	Code	Qty recommended spare parts
1		Tee-piece union	1/8" M x Ø4 x Ø4	1	1266120009	
2	EV2	Safety locks solenoid valve (pneumatic type)		1	1281320020	1
3		Cylinders (mechanical safety devices on lifting cylinders)		2	1251041005R	2
4		Screw	T.C.E.I. M4X16	4	1011040160	
5		Linear nipple	M05X04	2	1265010109	
6		Hose	Ø4	12 mt	1291060008	

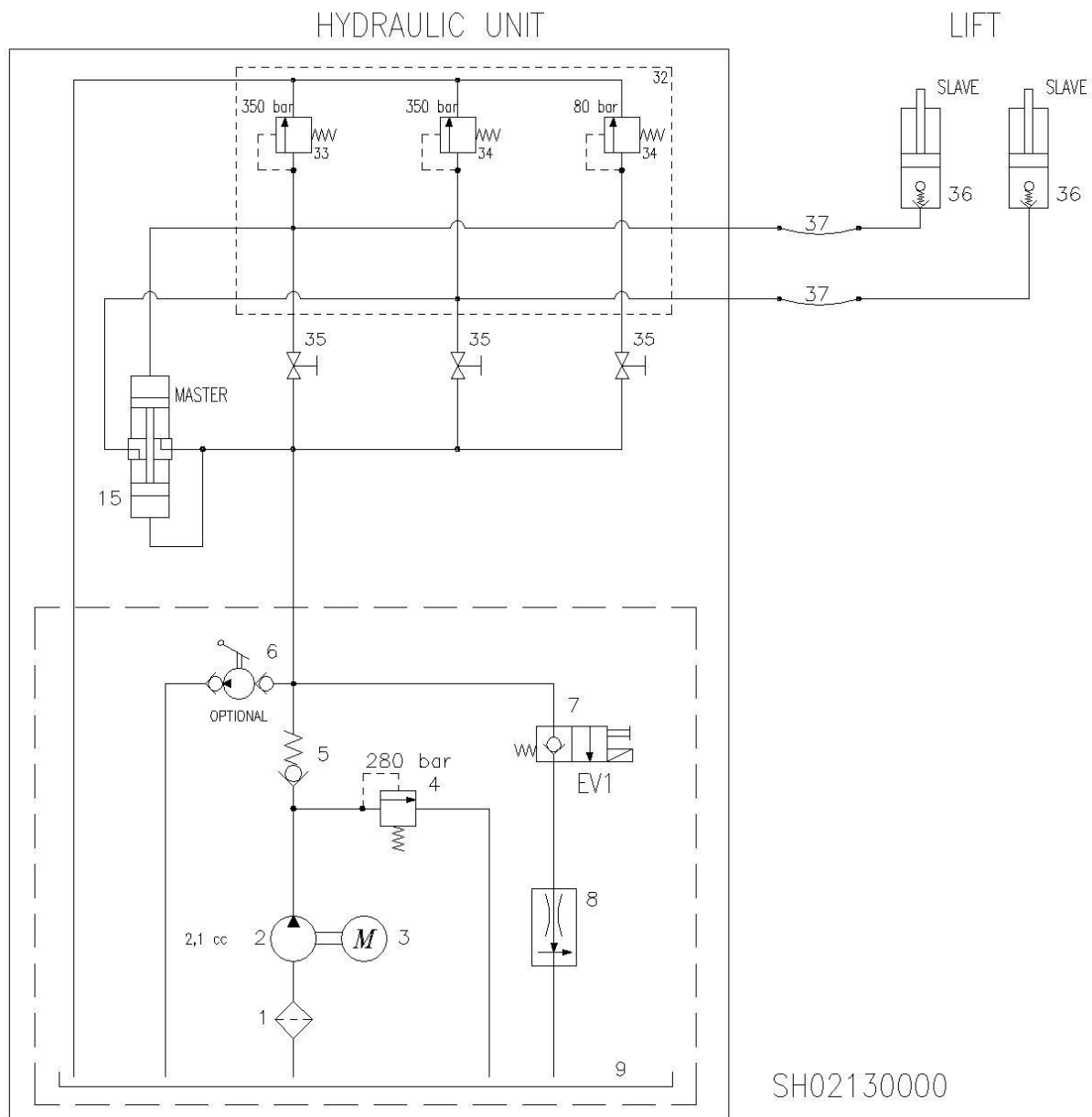

MINI 30 VX

SH02130000

TABLE

2b

HYDRAULIC CONTROL UNIT

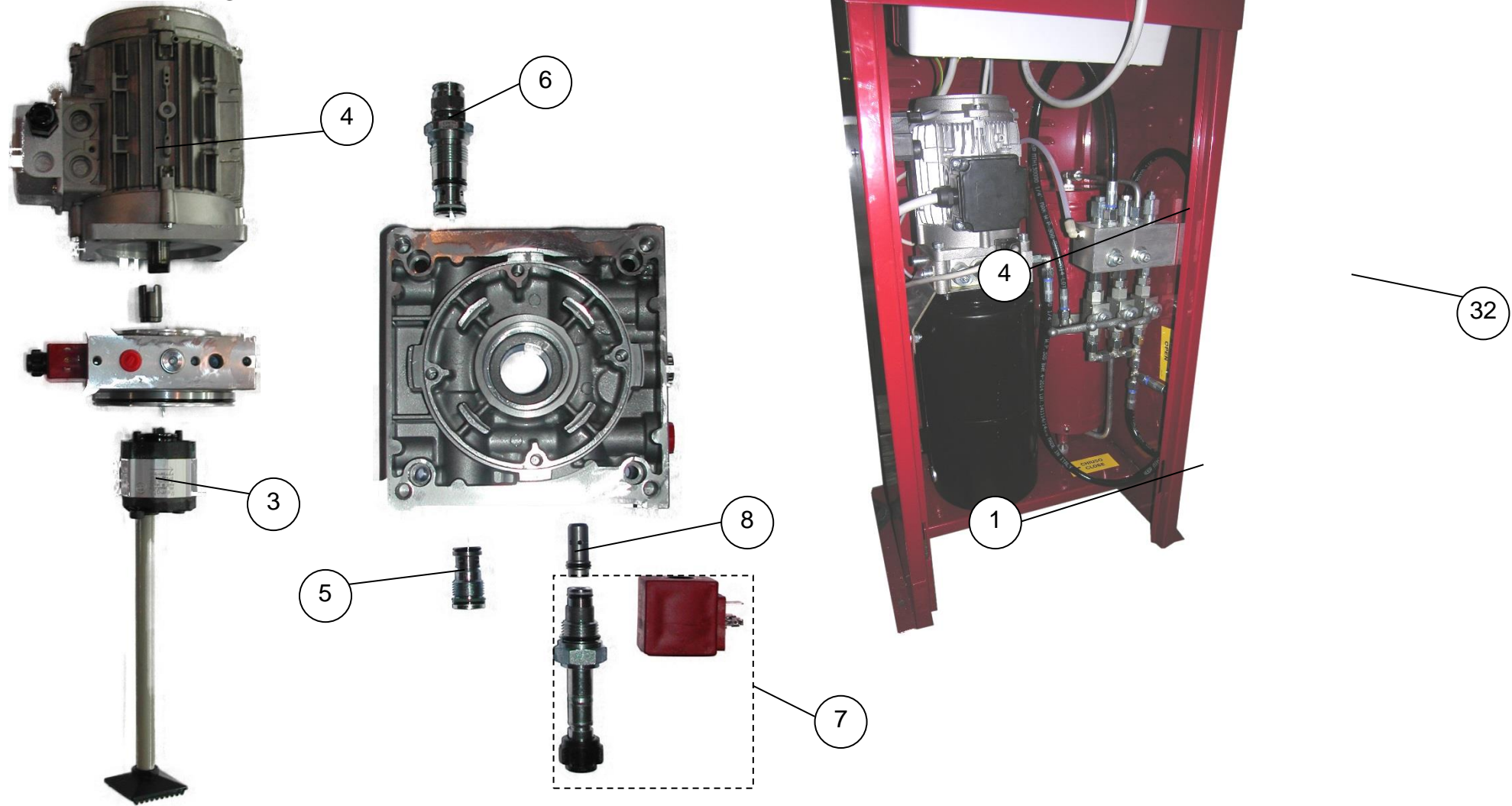

Pos.	Abbr.	Description	Type	Q.ty	Code	Q.ty recommended spare parts
					1120130030R	1
3		Gear pump		1	1211002100R	1
4	M1	Electric motor		1	1351040030R	1
5		Check valve		1	1901900045R	1
6		Relief valve		1	1120160100 + 1281490130	1
7	EV1	Downstroke solenoid valve	KIT	1	1901901930R	1
8		Throttling		1	1281000180R	1

15	MASTER	Hydraulic cylinder		1	3023121670	
32		Hydraulic block		1	3036025099	
33		Relief valve	80 bar	1	1120160100R	1
34		Relief valve	350 bar	2		
35		Cock		3	1251120000	
36	SLAVE	Hydraulic cylinder		2	Tavola/Table 4	
37		Flex hose		2	1201404500	
40		Linear nipple	M1/4"X8	5	1161030008	
41		Linear nipple	1/4"MXC OD.8	6	1161260007	
42		Tee-piece union	14X1,5	2	1164120008	
43		Tee-piece union	8X8X8	1	1166020008	

MOTORE/MOTOR

POS.	V	Hz	Phase	Pow (KW)
4	230	60	1	1.5

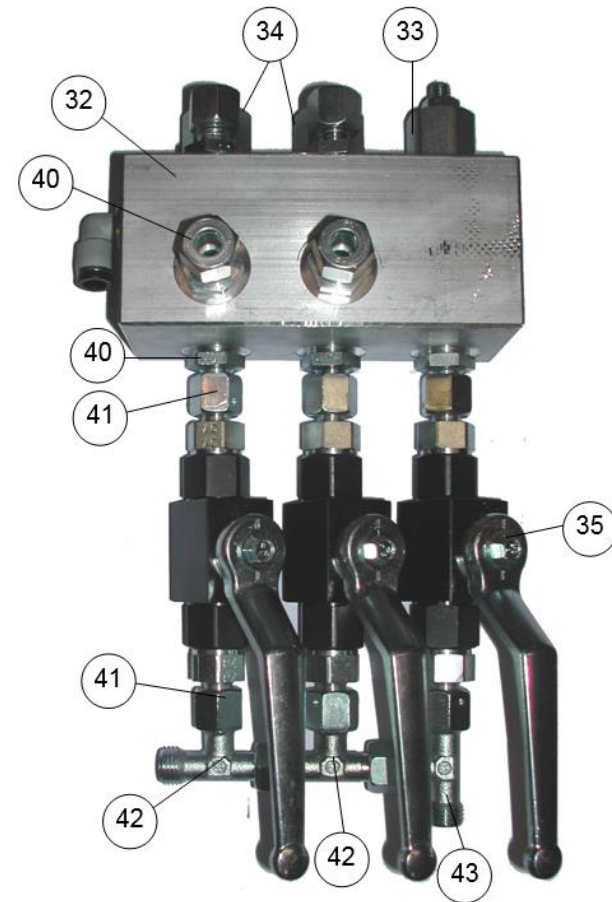
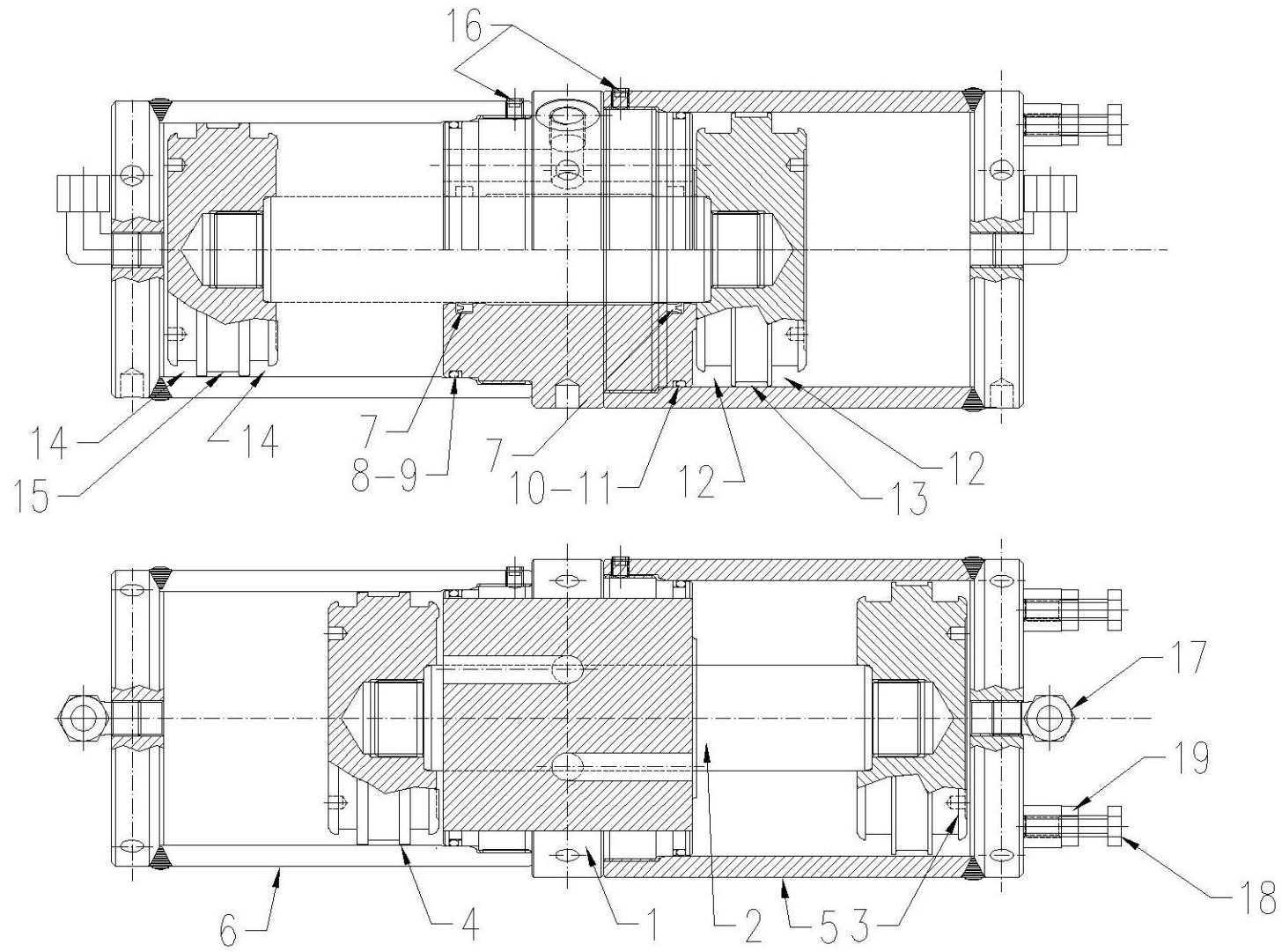
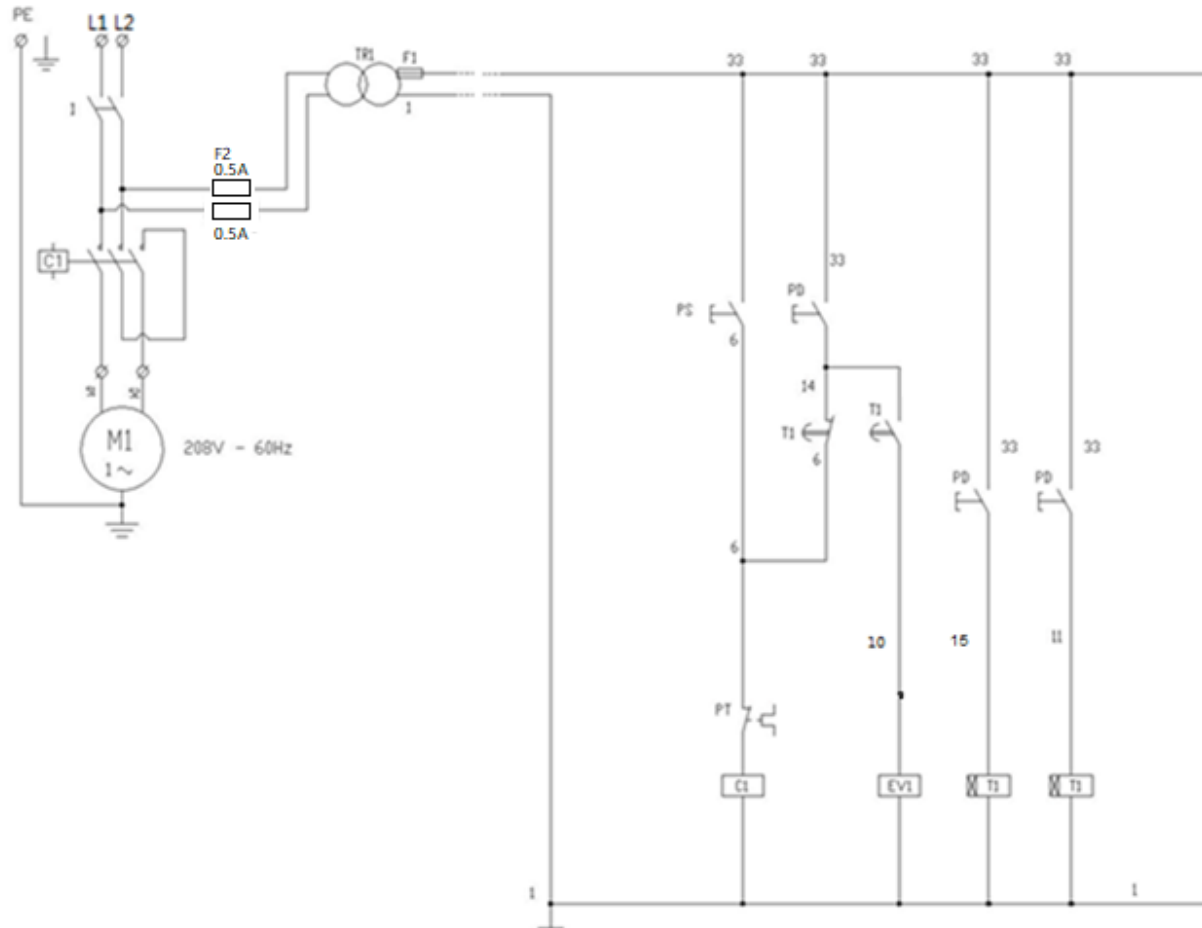

TABLE 2C OIL DIVIDER CYLINDER



Pos	Description	Type	Q.ty	Code	Q.ty recommended spare parts
1	Holder	Ø150 L=120	1	3036900556	
2	Cylinder rod	Ø50 L=258	1	3023121673	
3	Holder	Ø130	1	3036900565	
4	Holder	Ø120	1	3036900570	
5	Jacket	Ø130	1	3023121671	
6	Jacket	Ø120	1	3023121674	
	Seal pack		1	3023121670KR	1
7	Seal	50x60x8	2		
8	Seal OR	113.90x3.53	1		
9	Piston ring		1		
10	Seal OR		1		
11	Piston ring		1		
12	Seal		2		
13	Guide band		1		
14	Seal		2		
15	Guide band		1		
16	Screw	M8 L=10	2	1023080103	
17	Elbow joint	3/8 Mx Ø12	4	1162080007	
18	Screw	M10x40	3	1003100400	
19	Nut	M10	3	1052100000	

TABLE 3A CONSOLE WIRING DIAGRAM



Abbr.	Description
PD	Table down button
PS	Up button
M1	Electric motor
RT	Overload thermal relay
C1	Contactor
TR1	Transformer
F1	Fuse
EV1	Lowering control solenoid valve
EV2	Safety locks solenoid valve (pneumatic type)

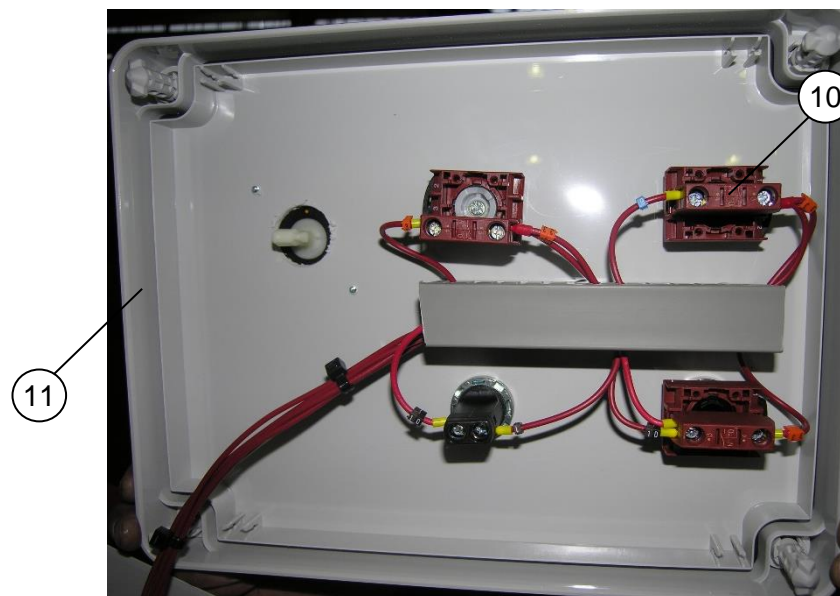
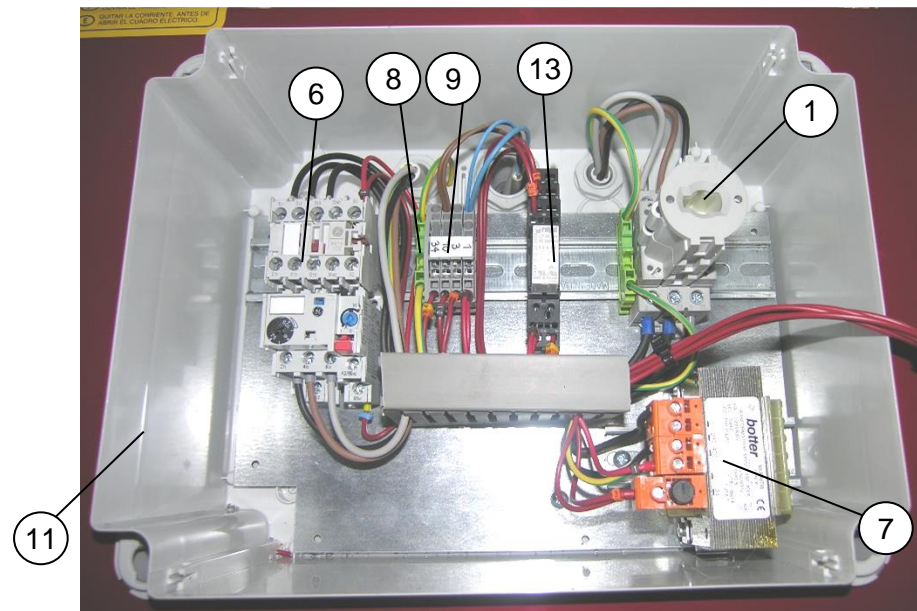

Ref.	Abbr.	Description	Qty	Code	Q.ty recommended spare parts
1	I	Main switch	1	1371040050	
2	PD	Table down button	1	1481010040	
3	PS	Up button	1	1481010010	
5	RT	Overload thermal relay	1	1391000010	
6	C1	Contactora	1	1381000010R	1
7	TR1+F1	Transformer	1	1361390000R	1
		Fuse			
8		YG terminal board	2	1421020000	
9		Terminal board			
10		NO contacts	1	1411000010	
11		Perforated plastic box	1	1491110000	
13	RFOT	Relay	1	1391080004R	1

TABLE

4

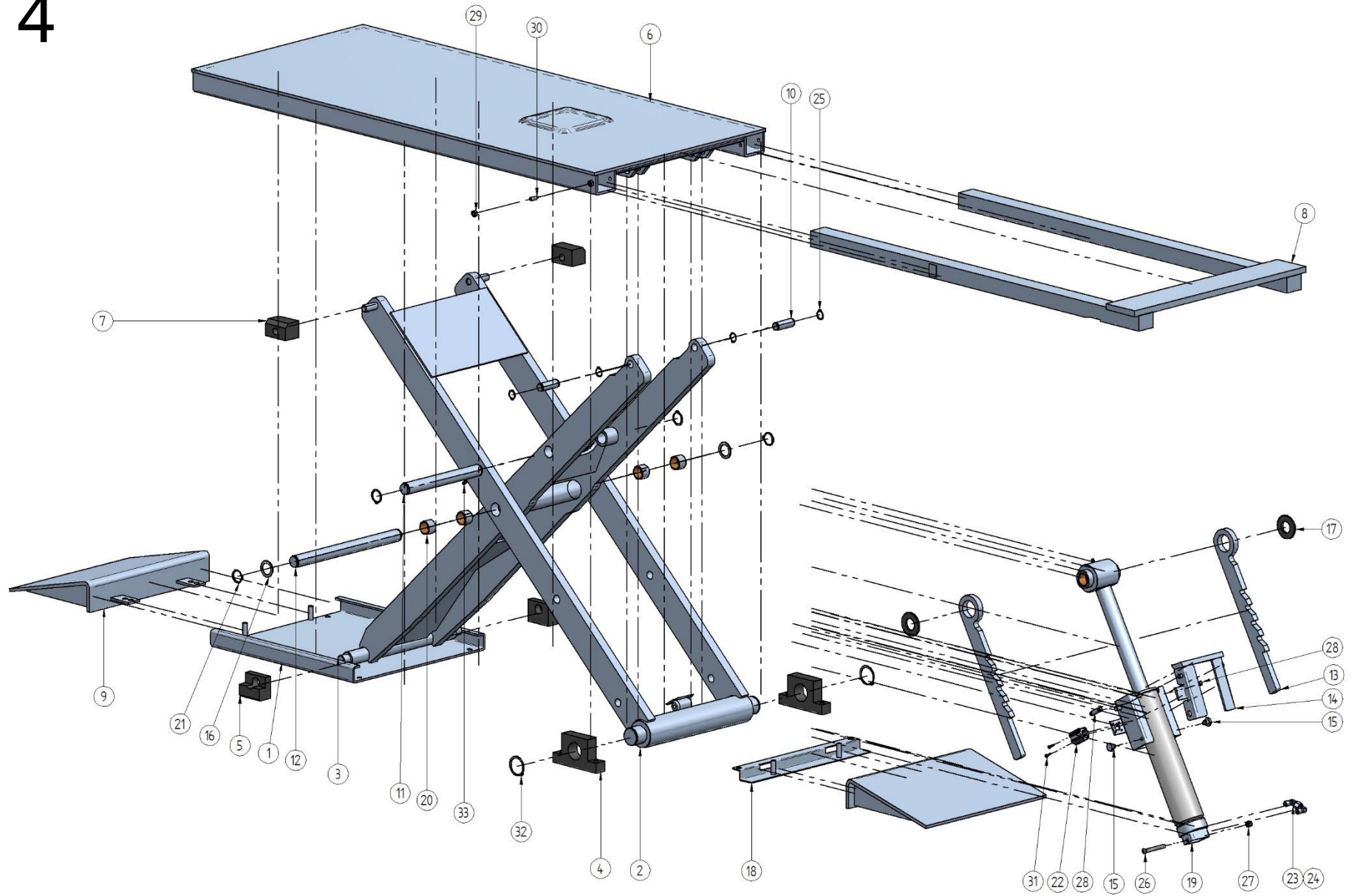

Pos.	Description	Tipo Type	Q.tà Q.ty	Codice Code	Q.tà ricambi raccomandati Q.ty recommended spare parts
1	Base		1	3023121610	
2	Arm	FISSO - FIXED	1	3023121620	
3	Arm	MOBILE	1	3023121630	
4	Support		2	3028150110	
5	Sliding block		2	3023120260	2
6	Platform		1	3023121640	
7	Sliding block		2	3023121693	2
8	Extension		1	3023121650	
9	Drive on ramp		2	3023120400	
10	Pin		2	3023121286	
11	Pin		1	3023121691	
12	Pin		1	3023121690	
13	Safety lock		2	3023121686	
14	Plate		1	3023121682	
15	Screw		2	3036020191	
16	Spacer		2	3022101110	
17	Spacer		2	3023121694	
18	Ramp fastening		1	3023121613	
19	Cylinder		1	3023121660	
20	Bushing	Glycodur GLY.PG 303425F	4	1141160000	4
21	Clamping ring	Ø30 UNI7436-E	4	1071300004	
22	Pneumatic cylinder	WS0 160 014 S	1	1251041005	1
23	Elbow joint	1-4M x 1-4M P-WEV	1	1162030008	
24	Elbow joint	1-4M x Tubo 8 P-WV	1	1162310008	
25	Clamping ring	Ø20 UNI 7435-E	4	1071200003	
26	Screw	TBEI UNI ISO 7380 M8x50	1	1034080700	
27	Nut	M8 UNI 7473	1	1056080000	
28	Spring washer	De10 df1 L=28	2	3000504470	
29	Nut	tipo 1 UNI EN ISO 4032 A M8	1	1052080000	
30	Screw	STEI UNI 5925 M08x25	1	1022080253	
31	Screw	TCEI UNI5931 M4x16	2	1011040160	
32	Clamping ring	Ø45 UNI 7435-E	2	1071450003	
33	Greasing nipple	UNI 7663 A - M6	1	1141030000	

TABLE 5 LIFTING CYLINDER

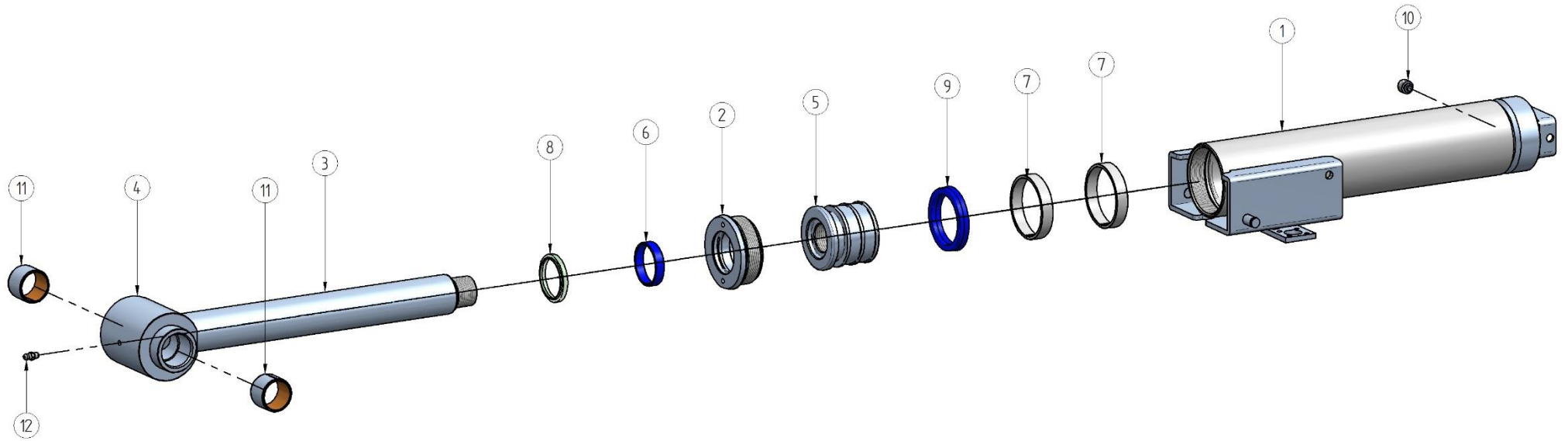

Pos.	Description	Type	Q.ty	Code	Qty recommended spare parts
1	Jacket		1	3023121661	
2	Ring nut		1	3023121665	
3	Cylinder rod		1	3023121663	
4	Rod connection		1	3023121666	
5	Holder		1	3023121664	
	Seal pack		1	3023121660K	1
6	Guide band	Guarnitec TF03-9720 9,7x2 Di=40 L=131			
7	Guide band	Guarnitec TF 03-12830 12,8x3 De=65 L=192			
8	Screaper ring	GHM316-157188 48.6x43x40x5.3			
9	Seal	TTU1757 - 65x50x11			
10	Stop valve	1/4" LB1C	1	1281220011	
11	Bushing	Glycodur GLY.PG 303425F	2	1141160000	
12	Greasing nipple	UNI 7663 A - M6	1	1141030000	