

coats®



Model:

4TLM6R4

6,000 lb. (2721 kg)

MID RISE

Installation / Operation & Service Parts Manual

**READ the Manual Thoroughly Before Installing,
Operating, Servicing, or Maintaining the Lift**

SAVE this MANUAL and ALL INSTRUCTIONS

Total Automotive Lifting Solutions Inc.
2300 Speers Rd. Oakville, Ontario L6L 2X8
Phone: (905) 847-1198 Fax: (905) 891-1214
www.TLSLifts.com

Part Number : D-MR-06
Effective: SEP., 2017

Lift Purchase Buyers Agreement

Warranty

Each product comes with a two (2) year parts warranty with five (5) years warranty on the structure. The parts warranty is limited to defects in workmanship and material. The warranty does not cover misuse, abuse, overloading, lack of maintenance, and inappropriate use or "normal wear and tear". Warranty parts must be returned to manufacturer for inspection to qualify for warranty. Shipping costs are the owner's responsibility.

Freight Damage

Each lifting product is carefully inspected before being loaded by our shipping department. Any damage to the product must be noted on the shipping companies "bill of lading" and signed by the driver. It is the owner's responsibility to advise manufacturer within **48 business hours**, of any shipping damage.

Installation

At the purchase request, delivery and installation can be arranged by a professional contractor. It is the owner's responsibility to approve the completion of the work done and that the product is working properly. If there is a dispute with the work being done the owner must advise our office within **24 business hours**.

Lift Maintenance

Every lifting product will require ongoing adjustment and maintenance. It is normal that the lifting cables will require adjustment to ensure that the lift operates level. Periodic adjustments are the owner's responsibility. If the owner requires the assistance of a lift technician, a service charge will be paid directly for a service call. The lift is manufactured with a baked on power coat finish. It is recommended to maintain this finish that scratches are periodically touched up with automotive style paint. All non-painted services should be kept clean and lubricated to prevent rust or corrosion.

Service Calls

Onsite service of your lifting product can be arranged by a qualified lift service technician. The owner will be responsible for paying the contractor directly for this service at the time the work is completed. It is the owner's responsibility to return any parts to manufacturer for warranty consideration.

Your new lift will provide years of dependable service if installed, operated and maintained properly. Read and follow all safety, installation, operation, and maintenance instructions in this manual before installing and operating the lift. In addition, read and follow all safety and other information included on and with the lift before operating the lift. **Keep this manual in a secure place for future reference, training and service part identification.**

TABLE of CONTENTS

1. Unloading Procedure & Lift Package Contents	page 4
2. Important Safety Instructions	page 5
3. General Requirements & Lift Specifications	page 7
4. Installation And Operation Instructions	page 8
5. Troubleshooting	page 20
6. Lift Installation Diagrams & Parts Lists	page 22

IMPORTANT: It is the shop owner's responsibility to provide a satisfactory installation area for the lift. Lifts should only be installed indoors on level concrete floors with a minimum of 4 inches (102mm) and 3000 psi (20.7MPa) concrete that has been aged a minimum of 30 days. Please consult a qualified individual if any doubt exists concerning proper installation and subsequent safe operation of the lift. Do not install the lift on asphalt or outdoors.

Prior to installation, it is the shop owner's responsibility to provide constant electrical power in the correct voltage, phase, etc., and all wiring for electrical hook-up of the lift. The shop owner must insure that the electrical installation conforms to local building and safety codes. Where required, the shop owner will provide an electrical isolation switch located in close proximity to the lift. This switch will have an emergency stop capability and isolate electrical power from the lift for servicing requirements.

Hydraulic oil cannot be shipped with the lift and will be supplied by either the shop owner or the installer. ISO 32 hydraulic oil (10W non detergent hydraulic oil) must be used to fill the reservoir tank before operating the lift.

It is the shop owner's responsibility to train all operators in lift operation and safety.

1. UNLOADING PROCEDURE and LIFT PACKAGE CONTENTS

For your information:

All lift components are grouped together in one package held at each end by steel frames.

Unpacking Procedure:

When the lift arrives on site:

- ✓ If possible have the lift unloaded in the installation area.
- ✓ Check for freight damage and report immediately to the trucking company who delivered the lift.
- ✓ Check for missing parts and report immediately to the factory.

Main Components include:

- ✓ Lift Assembly – 1pc
- ✓ Powerpack Assembly – 1 pc

Accessory and Hardware Box includes:

- ✓ Rubber Stack Lifting Pad Assembly – 4 pc
- ✓ Lifting Adapters – 4 pc
- ✓ Extended Lifting Adapters – 4 pc
- ✓ Hydraulic Hose w/ Fittings – 1pc
- ✓ Hardware Box
- ✓ Owner's Manual

2. IMPORTANT SAFETY INSTRUCTIONS

When using your garage equipment, basic safety precautions should always be followed, including the following:

1. Read all instructions
2. Do not operate equipment with a damaged cord or if equipment has been dropped or damaged – until it has been examined by a qualified service person
3. To reduce risk of fire, do not operate equipment in the vicinity of open containers of flammable liquids (gasoline)
4. Adequate ventilation should be provided when working on operating internal combustion engines
5. Keep hair, loose clothing, fingers, and all parts of body away from moving parts
6. To reduce the risk of electric shock, do not use on wet surfaces or expose to rain
7. Use only as directed in this manual. Use only manufacturer's recommended attachments
8. ALWAYS WEAR SAFETY GLASSES. Everyday eyeglasses only have impact resistant lenses, they are not safety glasses

Basic common sense safety precautions should always be followed when installing, operating and maintaining the lift as a risk of fire, electric shock, injury or death may be present.

In addition:

1. Only trained and authorized personnel should position a vehicle and operate the lift.
2. Inspect the lift daily. Do not operate if potential problems have been identified or lift malfunctions. Do not operate if lift has damaged or broken components. Never walk or work under the lift unless all safety locks are completely engaged.
3. Never overload the lift. The hydraulic system on this lift is not designed to be a load holding device. Mechanical safety locks must be engaged before proceeding under the lift for vehicle servicing or lift maintenance. Never override operating controls. This is unsafe and will void the warranty.
4. Before driving a vehicle onto the lift, insure that the lift and lift area is clear of all debris and that all oil and grease has been cleaned from runway surfaces.
5. Always chock wheels and set parking brake before lifting vehicle.
6. When using a jack(s) to raise a vehicle, position jack lifting pads to contact vehicle manufacturers recommended lifting points. Raise jack slowly until all pads contact the vehicle. Confirm that the vehicle is stable on the jack(s) before raising to desired working height.
7. Important: Removal or installation of heavier parts can change the vehicle's center of gravity on the jack(s) resulting in a critical load shift. The vehicle may then be unstable. Plan ahead for this possibility to insure continued safety and refer to the vehicle manufacturer's service manual for recommended procedures.
8. Always keep the lift area free of obstructions and debris. Grease and oil spills should be cleaned up immediately.
9. Never raise a vehicle on the lift with passengers inside. Before lowering, check the lift

and lift area and remove all obstructions. Before removing vehicle from the lift or lift area, confirm an unobstructed exit.

10. DO NOT PERFORM ANY MAINTENANCE OR INSTALLATION OF ANY COMPONENTS WITHOUT FIRST ENSURING THAT ELECTRICAL POWER HAS BEEN DISCONNECTED AT THE SOURCE OR PANEL AND CANNOT BE RE-ENERGIZED UNTIL ALL MAINTENANCE AND/OR INSTALLATION PROCEDURES ARE COMPLETED (ANSI 244.1).

SAVE THESE INSTRUCTIONS

3. GENERAL REQUIREMENTS & LIFT SPECIFICATIONS

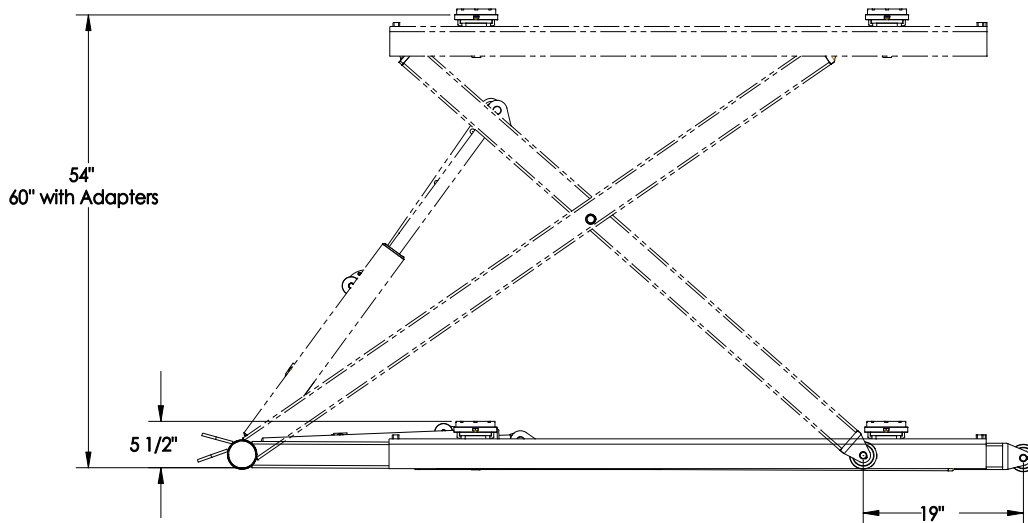
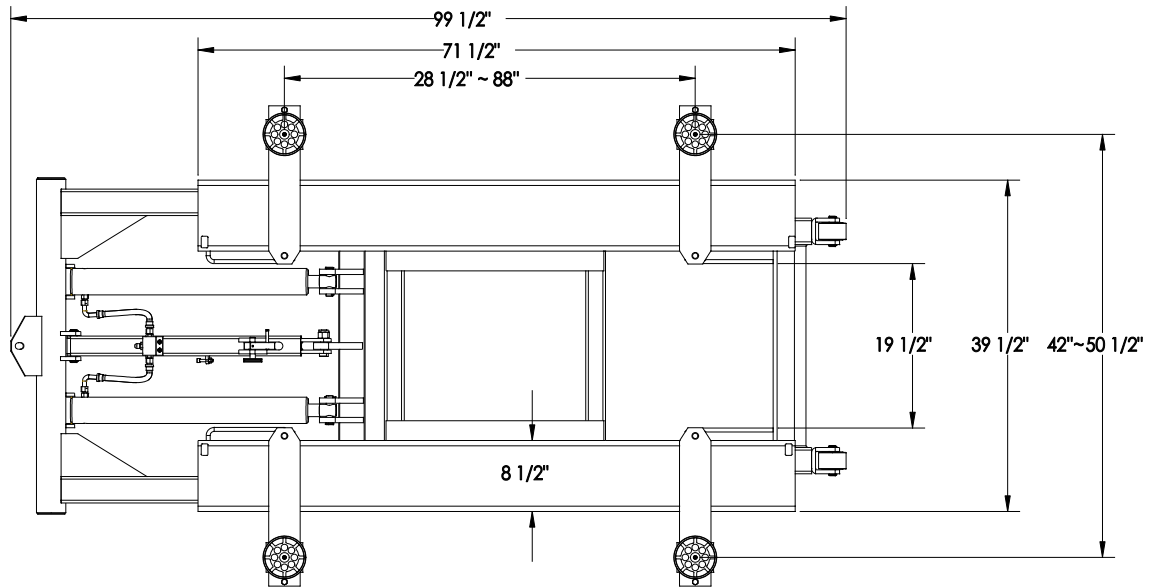

6,000 (2727 kg) Capacity – 1,500 lbs. Each Lifting Pad

Constant supply of 230V or 115V 1PH 60Hz 20A electrical power is required for this lift.

Whenever you find the following warning sign in this guide, pay the utmost attention and follow the relevant safety rules.



ATTENTION: Read the following directions with the utmost attention. Non-observance of described procedures/practices can cause serious damages to bystanders.



IN THE EVENT OF RAISED VEHICLE FALLS FROM THE LIFT, RUN AWAY TO A SAFE DISTANCE.



DO NOT STAND UNDER THE VEHICLE ON THE LIFT WHILE LIFT IS OPERATING.
DEATH OR SERIOUS INJURY MAY OCCUR.



DO NOT LIFT ONE SIDE OF THE VEHICLE.
POSSIBILITY OF VEHICLE OVERTURN AND/OR DAMAGE TO LIFT MAY HAPPEN.



DO NOT PLACE ANY POLES UNDER THE VEHICLE AND LOWER IT TO DISMANTLE THE PART FROM THE RAISED VEHICLE.



DO NOT MODIFY ANY SAFETY SYSTEMS OF HOIST.
IF SAFETY DEVICE MALFUNCTIONS, SERIOUS ACCIDENT MAY OCCUR.



DO NOT SHAKE A RAISED VEHICLE EXCESSIVELY.
DANGER OF VEHICLE FALLING FROM LIFT MAY OCCUR.



DO NOT PLACE FEET UNDER ANY MOVING PART OF LIFT WHILE LOWERING.



DO NOT OPERATE A LIFT WITH PEOPLE ON IT.



LIFT TO BE USED BY TRAINED OPERATOR ONLY



ELECTRICAL SHOCK MAY OCCUR WHEN OPENING CONTROL BOX



AUTHORIZED PERSONNEL ONLY IN LIFT AREA



ALWAYS USE SAFETY STANDS WHEN REMOVING OR INSTALLING HEAVY COMPONENTS



DO NOT SPRAY WATER DIRECTLY ONTO LIFT.



READ OPERATING AND SAFETY MANUALS BEFORE USING LIFT



DO NOT OPERATE A DAMAGED LIFT



PROPER MAINTENANCE AND INSPECTION ARE NECESSARY FOR SAFE OPERATION

WORK AREA

1. **Keep your work area clean and well lit.** Cluttered benches and dark areas invite accidents.
2. **Do not operate power equipment in explosive atmospheres, such as in the presence of flammable liquids, gases, or dust.** Power equipment can create sparks which may ignite flammables.
3. **Keep bystanders, children, and visitors away while operating power equipment.** Distractions can cause you to lose control.

PERSONAL SAFETY

1. **Stay alert. Watch what you are doing, and use common sense when operating power equipment. Do not use power equipment while tired or under the influence of drugs, alcohol, or medication.** A moment of inattention while operating power equipment may result in serious personal injury.
2.  **RISK OF ENTANGLEMENT! Dress properly. Do not wear loose clothing or jewelry. Contain long hair. Keep your hair, clothing, and gloves away from moving parts.** Loose clothes, jewelry, or long hair can be caught in moving parts.
3. **Avoid accidental starting. Be sure the Power Switch is off before plugging in.** Plugging in power equipment with the Power Switch on invites accidents.
4. **Remove adjusting keys or wrenches before turning on power equipment.** A wrench or a key that is left attached to a moving part of power equipment may result in personal injury.
5. **Do not overreach. Keep proper footing and balance at all times.** Proper footing and balance enables better control of the power equipment in unexpected situations.
6. **Use safety equipment. Always wear ANSI approved safety impact eye goggles underneath a full face shield.**

TOOL USE AND CARE

1. **Use clamps (not included) or other practical ways to secure and support the workpiece to a stable platform.** Holding the work by hand or against your body is unstable and may lead to loss of control.

2. **Do not force power equipment. Use the correct equipment for your application.** The correct equipment will do the job better and safer at the rate for which it is designed.
3. **Do not use power equipment if the Power Switch does not turn it on or off.** Any equipment that cannot be controlled with the Power Switch is dangerous and must be repaired or replaced.
4. **Disconnect the Power Cord Plug from the power source before making any adjustments, changing accessories, or storing the power equipment.** Such preventive safety measures reduce the risk of starting the equipment accidentally.
5. **Store idle equipment out of reach of children and other untrained persons.** Power equipment is dangerous in the hands of untrained users.
6. **Maintain power equipment with care.** Properly maintained equipment are less likely to fail and are easier to control. Do not use damaged power equipment. Tag damaged power equipment "Do not use" until repaired.
7. **Check for misalignment or binding of moving parts, breakage of parts, and any other condition that may affect the power equipment's operation. If damaged, have the equipment serviced before using.** Many accidents are caused by poorly maintained power equipment.
8. **Use only accessories that are recommended by the manufacturer for your model.** Accessories that may be suitable for one power equipment may become hazardous when used on another power equipment.

SERVICE

1. **Tool service must be performed only by qualified repair personnel.** Service or maintenance performed by unqualified personnel could result in a risk of injury.
2. **When servicing a tool, use only identical replacement parts. Follow instructions in the "Inspection, Maintenance, And Cleaning" section of this manual.** Use of unauthorized parts or failure to follow maintenance instructions may create a risk of electric shock or injury.

ELECTRICAL SAFETY

1. **Grounded tools must be plugged into an outlet properly installed and grounded in accordance with all codes and ordinances. Never remove the grounding prong or modify the plug in any way. Do not use any adapter plugs. Check with a qualified electrician if you are in doubt as to whether the outlet is properly grounded.** If the tools should electrically malfunction or

break down, grounding provides a low resistance path to carry electricity away from the user.

2. **Double insulated tools are equipped with a polarized plug (one blade is wider than the other). This plug will fit in a polarized outlet only one way. If the plug does not fit fully in the outlet, reverse the plug. If it still does not fit, contact a qualified electrician to install a polarized outlet. Do not change the plug in any way.** Double insulation  eliminates the need for the three wire grounded power cord and grounded power supply system.
3. **Avoid body contact with grounded surfaces such as pipes, radiators, ranges, and refrigerators.** There is an increased risk of electric shock if your body is grounded.
4. **Do not expose power tools to rain or wet conditions.** Water entering a power tool will increase the risk of electric shock.
5. **Do not abuse the Power Cord. Never use the Power Cord to carry the tools or pull the Plug from an outlet. Keep the Power Cord away from heat, oil, sharp edges, or moving parts. Replace damaged Power Cords immediately.** Damaged Power Cords increase the risk of electric shock.
6. **When operating a power tool outside, use an outdoor extension cord marked "W-A" or "W".** These extension cords are rated for outdoor use, and reduce the risk of electric shock.

GROUNDING

WARNING!

Improperly connecting the grounding wire can result in the risk of electric shock. Check with a qualified electrician if you are in doubt as to whether the outlet is properly grounded. Do not modify the power cord plug provided with the tool. Never remove the grounding prong from the plug. Do not use the tool if the power cord or plug is damaged. If damaged, have it repaired by a service facility before use. If the plug will not fit the outlet, have a proper outlet installed by a qualified electrician.

GROUNDED TOOLS: TOOLS WITH THREE PRONG PLUGS

1. Tools marked with "Grounding Required" have a three wire cord and three prong grounding plug. The plug must be connected to a properly grounded outlet. If the tool should electrically malfunction or break down, grounding provides a low resistance path to carry electricity away from the user, reducing the risk of electric shock. **(See Figure A.)**
2. The grounding prong in the plug is connected through the green wire inside the cord to the grounding system in the tool. The green wire in the cord must be the only wire connected to the tool's grounding system and must never be attached to an electrically "live" terminal. **(See Figure A.)**
3. Your tool must be plugged into an appropriate outlet, properly installed and grounded in accordance with all codes and ordinances. The plug and outlet should look like those in the following illustration. **(See Figure A.)**

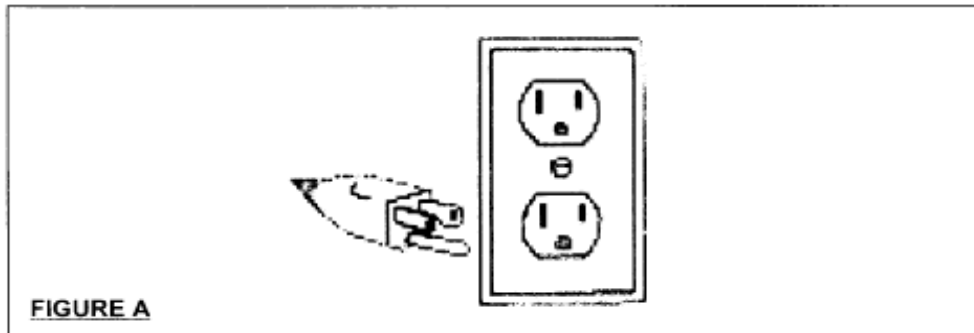

FIGURE A

EXTENSION CORDS - 115 VOLT

1. **115 volt Double Insulated** power equipment can use either a two or three wire 115 volt extension cord.
2. As the distance from the supply outlet increases, you must use a heavier gauge extension cord. Using extension cords with inadequately sized wire causes a serious drop in voltage, resulting in loss of power and possible tool damage. **(See Figure B, next page.)**
3. The smaller the gauge number of the wire, the greater the capacity of the cord. For example, a 14 gauge cord can carry a higher current than a 16 gauge cord. **(See Figure B.)**
4. When using more than one extension cord to make up the total length, make sure each cord contains at least the minimum wire size required. **(See Figure B.)**
5. If you are using one extension cord for more than one tool, add the nameplate amperes and use the sum to determine the required minimum cord size. **(See Figure B.)**
6. If you are using an extension cord outdoors, make sure it is marked with the suffix "W-A" ("W" in Canada) to indicate it is acceptable for outdoor use.
7. Make sure your extension cord is properly wired and in good electrical condition. Always replace a damaged extension cord or have it repaired by a qualified electrician before using it.
8. Protect your extension cords from sharp objects, excessive heat, and damp or wet areas.

REQUIRED MINIMUM EXTENSION CORD GAUGE - 115 VOLT					
NAMEPLATE AMPERES (At Full Load)	EXTENSION CORD LENGTH				
	25 Feet	50 Feet	75 Feet	100 Feet	150 Feet
0 - 2.0	18	18	18	18	16
2.1 - 3.4	18	18	18	16	14
3.5 - 5.0	18	18	16	14	12
5.1 - 7.0	18	16	14	12	12
7.1 - 12.0	18	14	12	10	-
12.1 - 16.0	14	12	10	-	-
16.1 - 20.0	12	10	-	-	-

* Based on limiting the line voltage drop to five volts at 150% of the rated amperes.

FIGURE B

EXTENSION CORDS - 230 VOLT

1.  **IMPORTANT!** If the Scissor Lift is to be powered by a 230 volt, grounded, electrical outlet, a 230 volt grounded Power Cord (not included) must be wired to the Motor (1A). Also, a 230 volt, grounded, Power Cord Plug (not included) must be attached to the Power Cord. **THIS WIRING PROCEDURE MUST ONLY BE DONE BY A QUALIFIED, CERTIFIED ELECTRICIAN.**
(See Figure C, next page.)

REQUIRED MINIMUM EXTENSION CORD GAUGE – 230 VOLT				
NAMEPLATE AMPERES (At Full Load)	EXTENSION CORD LENGTH			
	0-25 Feet	25-50 Feet	50-100 Feet	100-150 Feet
6	18	16	14	12
8	18	16	12	10
10	18	14	12	10
12	16	14	10	8
14	16	12	10	8
16	16	12	10	8
18	14	12	8	8
20	14	12	8	6
22	14	10	8	6
24	14	10	8	6
26	12	10	8	6
28	12	10	6	4
30	12	10	6	4

FIGURE C

SYMBOLOLOGY









	Double Insulated
	Canadian Standards Association
	Underwriters Laboratories, Inc.
	Volts Alternating Current
	Amperes
	No Load Revolutions Per Minute (RPM)



FIGURE D

SPECIFIC SAFETY RULES

1.  **DANGER!** Make sure you know the weight of the vehicle you are going to lift *before* using the Scissor Lift. Do not exceed the maximum lift capacity (6,000 pounds at 48" elevation) for the Scissor Lift. Overloading the Scissor Lift could cause personal injury and/or property damage. Be aware of

dynamic loading! If a weight suddenly falls onto the Scissor Lift, it may create for a brief instant an excess load which may result in personal injury and/or damage to the vehicle and Scissor Lift.

2.  **WARNING!** Use the Scissor Lift only in well ventilated areas. Carbon monoxide exhausted from running vehicle engines is a colorless, odorless fume that, if inhaled, can cause serious personal injury or death.
3. **Make sure to read and understand all instructions and safety precautions as outlined in the manufacturer's manual for the vehicle you are lifting.** All four Rubber Saddles (39B) of the Scissor Lift must be used when lifting a vehicle. Always use the manufacturer's recommended lifting points.
4. **Do not use the Scissor Lift on any asphalt surface.** Make sure the Scissor Lift is used on a dry, oil/grease free, flat, level, **CONCRETE** surface capable of supporting the weight of the Scissor Lift, the vehicle being lifted, and any additional tools and equipment. The concrete floor surface should have a minimum thickness of 5". The concrete must have a minimum strength of 4,000 PSI, and should be aged at least 30 days prior to use. Do not use the Scissor Lift on concrete expansion seams or on cracked, defective concrete.
5. **Always examine the Scissor Lift for structural cracks, bends, damage to the hydraulic hoses and electrical wiring, and any other condition that may affect the safe operation of the Lift.** Do not use the Scissor Lift even if minor damage is detected.
6. **IMPORTANT!** Operation (raising or lowering) of the Scissor Lift can be immediately stopped at any time by releasing pressure on the Power Switch located on the Motor (1A).
7. **Make sure the Oil Tank (13A) is completely filled (approx. 6.5 quarts) with a premium quality hydraulic oil prior to operating the Scissor Lift.**
8. **Always allow at least two seconds after the Motor (1A) starts to raise or lower the Scissor Lift.** Failure to do so may cause the Motor to burn out.
9. **Prior to beginning a job, make sure the Safety Lock Assembly (36B) and its Safety Catches are in the proper position.** NEVER work underneath a vehicle without using additional safety support devices (i.e., jack stands) to support the vehicle.
10. **Always keep hands, fingers, and feet away from the moving parts of the Scissor Lift when applying or releasing a load.** Remain clear of the Scissor Lift when raising or lowering a vehicle.
11. **Use extreme caution when applying or releasing a load.** Never allow the load to suddenly release. Slowly and carefully apply and release the load.
12. **Never leave the Scissor Lift unattended when the Lift is under a load.** Whenever the Scissor Lift is under a load there is a very large amount of force that has been stored in the Outside/Inside Scissors (24B, 25B) which must be controlled until the load is relaxed.
13. **Before driving a vehicle onto the Scissor Lift make sure the Lift is fully lowered.** Before driving a vehicle onto the Scissor Lift, position the Plates (42B) and Rubber Saddles (39B) inward. Do not hit or run over the Plates and Rubber Saddles, as this could damage the vehicle. Make sure the Scissor Lift is fully lowered before driving the vehicle off.

14. **Should any weight component be removed from, or added to the vehicle, use a jack stand (not included) to support the over balanced end during the maintenance procedure.** Do not operate the Scissor Lift if the vehicle load tilts or binds during the up or down movement. Always position the vehicle with the center of gravity midway between the Rubber Saddles (39B). Avoid excessive rocking of the vehicle while it is in its raised position.
15. **Never lift a vehicle with anyone inside it.** Do not allow others in the lift area while operating the Scissor Lift. Do not allow anyone to ride on the Scissor Lift while it is being raised or lowered.
16. **When lifting a vehicle raise the Rubber Saddles (39B) slowly until the Rubber Saddles securely contact the vehicle manufacturer's recommended lifting points.** Then, lift the vehicle to the desired working height. ALWAYS lift the vehicle high enough for the Safety Lock Assembly (36B) to operate properly.
17. **Do not use the Scissor Lift as a permanent stand for a vehicle.** Use the Scissor Lift only while making repairs. Then, immediately remove the vehicle from the Scissor Lift.
18. **Before lowering the Scissor Lift, make sure tool trays, stands, and all other tools and equipment are removed from under the vehicle.**
19. **Make sure to squeeze and hold in on the Brake Lever (13B) before attempting to lower the vehicle.** Do not release pressure on the Brake Lever until the Scissor Lift is completely lowered.
20. **Before removing a vehicle from the Scissor Lift make sure the Plates (42B) and Rubber Saddles (39B) are moved inward to provide an unobstructed exit.**
21.  **WARNING!** People with pacemakers should consult their physician(s) before using this product. Operation of electrical equipment in close proximity to a heart pacemaker could cause interference or failure of the pacemaker.
22.  **WARNING!** This product contains or produces a chemical known to the State of California to cause cancer and birth defects (or other reproductive harm). (*California Health & Safety Code 25249.5 et seq.*)
23.  **WARNING!** The warnings, precautions, and instructions discussed in this manual cannot cover all possible conditions and situations that may occur. The operator must understand that common sense and caution are factors which cannot be built into this product, but must be supplied by the operator.

ASSEMBLY INSTRUCTIONS

NOTE: For additional references to the parts listed in the following pages, refer to the **Assembly Diagrams on pages 16, 17, and 18.**

Determine The Proper Scissor Lift Location:

1. **Do not use the Scissor Lift on any asphalt surface.** Make sure the Scissor Lift is used on a dry, oil/grease free, flat, level, **CONCRETE** surface capable of supporting the weight of the Scissor Lift, the vehicle being lifted, and any additional tools and equipment. The concrete floor surface should have a minimum thickness of 5". The concrete must have a minimum strength of 4,000 PSI, and should be aged at least 30 days prior to use. Do not use the Scissor Lift on concrete expansion seams or on cracked, defective concrete.

2. Make sure to check the desired location for possible obstructions such as a low ceiling, overhead lines, adequate working area, access ways, exits, etcetera.
3. Make sure to allow a minimum space of 14 feet in front and behind the Scissor Lift to accommodate all vehicles. Certain allowances should be made for special vehicle requirements or unusual floor plans.

To Attach The Hydraulic Pump To The Scissor Lift:

1. Locate the Hydraulic Pump unit (1A through 15A) in an area where it will be out of the way, is safe from damage and weather, and where it can be easily reached to operate. (See Figure E.)

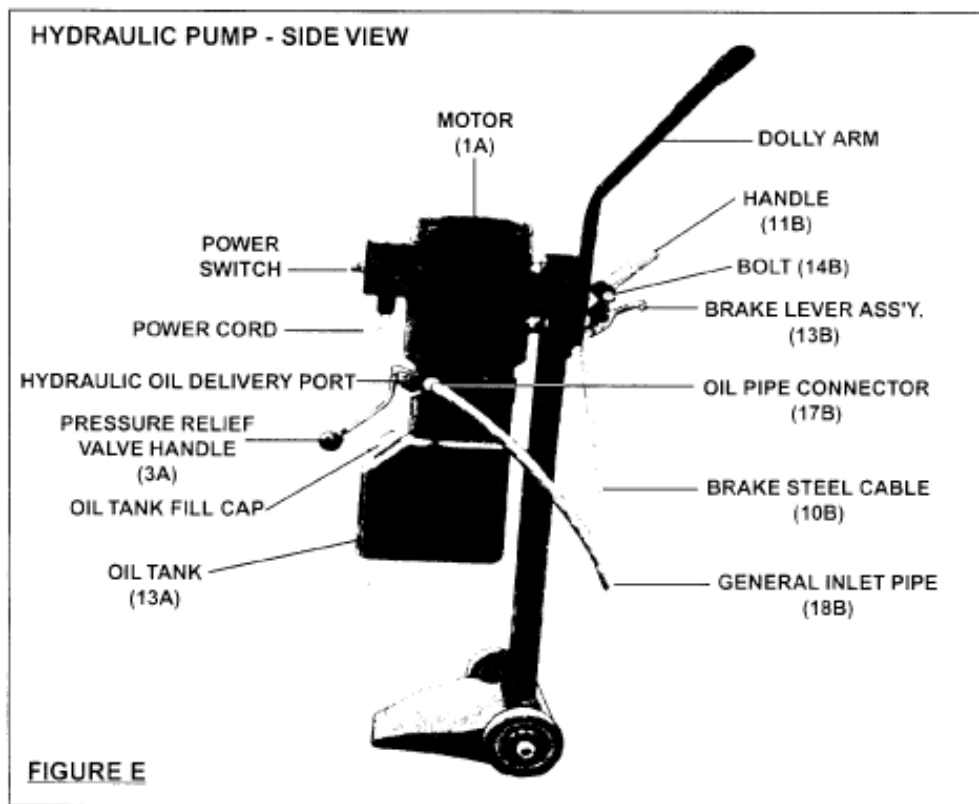

2. One end of the General Inlet Pipe (18B) has been pre-attached to the Scissor Lift by the manufacturer. To attach the remaining end of the General Inlet Pipe to the Hydraulic Pump wrap the male threads of the Oil Pipe Connector (17B) with about 4" of pipe thread seal tape (not included). Remove the Oil Filler Nut Cap (4A) from the threaded Hydraulic Oil Delivery Port. Then, wrench tighten the Oil Pipe Connector into the Hydraulic Oil Delivery Port. (See Figure E.)
3. One end of the Brake Steel Cable (10B) has been pre-attached to the Scissor Lift by the manufacturer. The Brake Lever Assembly (13B) is located on the remaining end of the Brake Steel Cable, and must be attached to the Handle (11B) of the Dolly. To do so, slide the Brake Lever Assembly onto the Handle. Then, secure the Brake Lever Assembly to the Handle by tightening the Bolt (14B). (See Figure E.)

To Fill The Oil Tank With Hydraulic Oil:

1. The hydraulic Oil Tank (13A) has a holding capacity of 6.5 quarts. To fill the Oil Tank, squeeze and hold the Brake Lever (13B) to release any load on the Scissor Lift. Remove the Oil Tank Fill Cap on the Oil Tank. Add a premium quality hydraulic oil until the level of the oil is even with the Oil Tank's fill hole. Then, replace the Oil Tank Fill Cap. **(See Figure E.)** Before the first use and before all subsequent uses, check the hydraulic oil tank to make sure the Oil Tank is properly filled.



TO HELP PREVENT SERIOUS INJURY AND/OR DEATH, READ AND UNDERSTAND ALL WARNINGS AND INSTRUCTIONS BEFORE USE.

OPERATING INSTRUCTIONS

Check The Safety Lock Assembly:

1.  **WARNING!** Never operate the Scissor Lift if the Safety Lock Assembly (1C through 11C) is not working properly. **(See Figure F, next page.)**
2. Plug the Power Cord of the Lift into a properly grounded, 3-hole, electrical receptacle and allow several seconds for the Motor (1A) to warm up. **(See Figure E.)**
3. Squeeze and release the Brake Lever (13B) several times and, while doing so, observe that the Safety Lock Assembly (1C through 11C) operates properly in response to the Brake Lever. Then, release pressure on the Brake Lever. **(See Figures E and F.)**
4. Press on the Power Switch and hold, and observe that the Safety Lock Assembly (1C through 11C) "clicks" into place as the Scissor Lift rises. **NOTE:** There are *safety catches* on the Safety Lock Assembly as the Scissor Lift rises. Once the Safety Lock Assembly locks into each of these safety catches, you must *squeeze and hold in* on the Brake Lever (13B) to lower the Scissor Lift. **(See Figures E and F.)**
5. Once the Scissor Lift is fully elevated, release pressure on the Power Switch. **(See Figure E.)**
6. Without squeezing the Brake Lever (13B), press in on the Pressure Relief Valve Handle (3A) and hold. Observe that the Scissor Lift will not lower, as the Safety Lock Assembly (1C through 11C) is engaged. **CAUTION! If the Safety Lock Assembly does not engage, fully lower the Scissor Lift and have a qualified service technician immediately repair the Safety Lock Assembly.** **(See Figures E and F.)**
7. Should the Safety Lock Assembly (1C through 11C) *not* operate as described in Step #6, raise the Scissor Lift slightly to take pressure off the safety catches. Then, while squeezing the Brake Lever (13B) lower the Scissor Lift fully to the floor. **NOTE:** When working properly, you must BOTH squeeze in and hold the Brake Lever and press in and hold the Pressure Relief Valve Handle (3A) to lower the Scissor Lift. **(See Figure E.)**

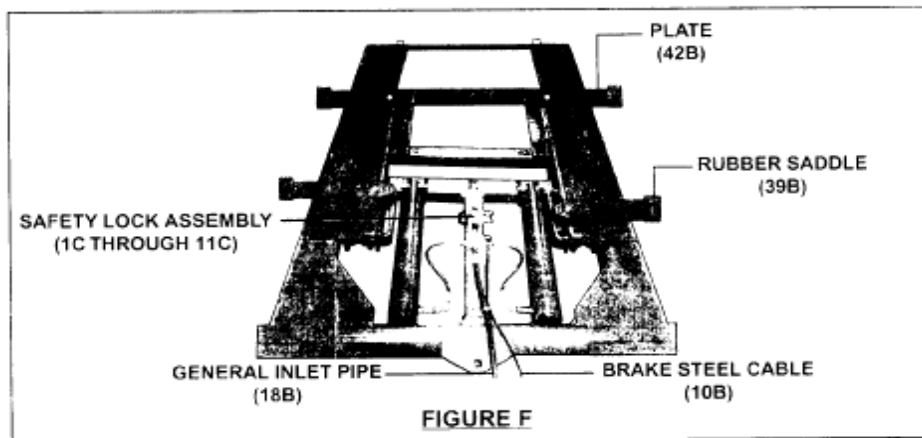

To Position, Lift, And Lower A Vehicle On The Scissor Lift:

1. Before driving a vehicle onto the Scissor Lift make sure that the Lift is fully lowered, and position the Plates (42B) and Rubber Saddles (39B) *inward*. (See Figure F.)
2. Drive the vehicle over the Scissor Lift while keeping the vehicle parallel with the Lift and aligning the center of gravity of the vehicle with the center of the Lift. **NOTE:** The "Center of Gravity" (COG) of the vehicle is the balance point at which there is equal weight in front of and behind the COG, and equal weight on both sides of the COG. The COG is not necessarily the dimensional center of the vehicle, but is often slightly toward the engine from the dimensional center of the vehicle. (See Figure G.)
3. Turn off the vehicle's engine and engage the parking brake of the vehicle.
4. Read the vehicle owner's manual to identify the recommended vehicle lifting points.
5. Move the Plates (42B) outward, and position the Rubber Saddles (39B) to contact the vehicle lifting points. (See Figures F and G.)
6. **WARNING!** Do not lift the vehicle if you cannot establish secure and level lifting points. Do not use sub-standard shims or other devices in place of approved and recommended Rubber Saddle (39B) adapters. Never use the Scissor Lift without the Rubber Saddles in place on each Plate (42B) and in contact with the lifting points of the vehicle. (See Figure F.)

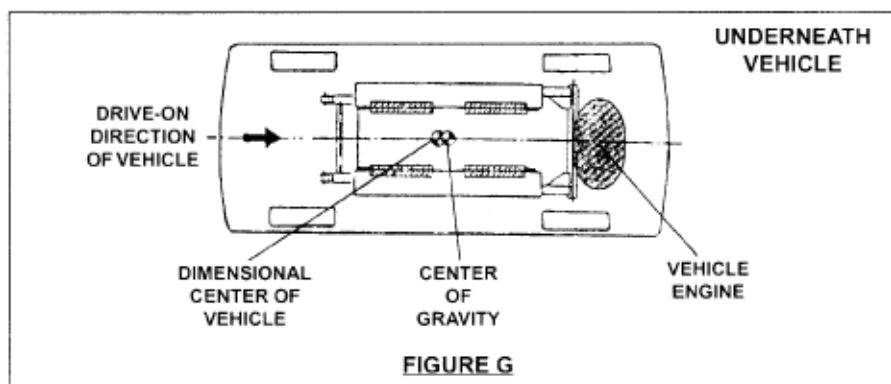

7. Once the Rubber Saddles (39B) have been positioned under the vehicle lifting points, operate the Power Switch to lift the vehicle slightly, and test to make sure the vehicle is well balanced and the contact between the Rubber Saddles and vehicle lifting points are secure. Then, proceed to lift the vehicle to the desired height. (See Figure F.)
8. **NOTE:** When the vehicle has been lifted to the desired height, and the Safety

Lock Assembly (1C through 11C) has locked in place, make sure to install proper safety jack stands (not included), under the vehicle once it is lifted to the desired height, as an additional safety measure.

9. Once the repair work to the vehicle is completed make sure to remove all tools, safety jack stands, and materials from under the vehicle and Scissor Lift. Also, make sure the work area is clear and it is safe to lower the vehicle.
10. To lower the Scissor Lift, use the Power Switch and raise the vehicle slightly to take weight off the Safety Lock Assembly (1C through 11C). Then, release pressure on the Power Switch. **(See Figure E.)**
11. Stand well away from the Scissor Lift and vehicle. Then squeeze and hold in the Brake Lever (13B) while at the same time pushing in and holding the Pressure Release Valve Handle (3A) to slowly lower the Scissor Lift all the way down to the floor. **(See Figure E.)**
12. Move the Rubber Saddles (39B) and Plates (42B) inward, out of the path of the vehicle. **(See Figure F.)**
13. Disengage the vehicle parking brake. Start the vehicle's engine, and drive the vehicle off the Scissor Lift slowly and carefully.

INSPECTION, MAINTENANCE, AND CLEANING

1.  **WARNING!** Always unplug the Power Cord from its electrical outlet before performing any inspection, adjustments, maintenance, or cleaning.
2. **Before each use**, inspect the general condition of the Scissor Lift. Check for loose screws, misalignment or binding of moving parts, cracked or broken parts, damaged electrical wiring and hoses, and any other condition that may affect its safe operation. If abnormal noise or vibration occurs, have the problem corrected before further use.
Do not use damaged equipment.
3. **Daily:** With compressed air or a vacuum, remove all dirt and debris from the Scissor Lift. Also, use a detergent or mild solvent to remove oil and grease from the unit. Then, use a premium quality, machine oil to lubricate all moving parts.
4. **Daily:** Check the level of hydraulic oil in the Oil Tank. The Oil Tank (13A) has a holding capacity of 6.5 quarts. To fill the Oil Tank, squeeze and hold the Brake Lever (13B) to release any load on the Scissor Lift. Remove the Oil Tank Fill Cap on the Oil Tank. Add a premium quality hydraulic oil until the level of oil is even with the Oil Tank's fill hole. Then, replace the Oil Tank Fill Cap. **(See Figure E.)**

LIFT PROBLEM TROUBLESHOOTING GUIDE

The following are some suggestions to consider if problems are encountered with the lift. Please call a Trained Lift Service Person for further clarification and information.

Problem	Possible Causes	Solutions
Lift Will Not Raise or Lower	<ol style="list-style-type: none"> 1. Blown fuse or circuit breaker 2. Incorrect voltage to motor 3. Bad wiring connections 4. "UP" switch burned out 5. Motor windings burned out 	<ol style="list-style-type: none"> 1. Replace fuse or reset/replace circuit breaker 2. Supply correct voltage to motor 3. Repair and insulate all connections 4. Replace switch 5. Replace motor
Lift Will Not Raise	<ol style="list-style-type: none"> 1. Air in oil or low oil level 2. Lowering Valve leaks 3. Motor runs backward 4. Pump damaged 5. Pump will not prime 6. Relief Valve leaks 7. Voltage to motor incorrect 8. Lift overloaded 	<ol style="list-style-type: none"> 1. Check fluid level, oil seal, bleed system 2. Clean valve or replace 3. Check for correct wiring 4. Repair or replace pump 5. Check fluid level and pick-up tube; replace pump 6. Clean Relief Valve (replace if necessary) 7. Supply correct voltage to motor 8. Verify that loaded vehicle weight does not exceed rated lift capacity
Lift Will Not Lower	<ol style="list-style-type: none"> 1. Mechanical locks are engaged 2. Obstruction under lift or in glide block tracks 3. Faulty lowering valve 	<ol style="list-style-type: none"> 1. Raise unit slightly and disengage mechanical locks 2. Carefully remove obstruction - clean glide block tracks 3. Replace valve
Lift Will Not Hold Pressure	<ol style="list-style-type: none"> 1. Contamination in system 2. Internal Cylinder leaks 3. Lowering Valve leaks 4. Check Valve leaks 5. External leaks 	<ol style="list-style-type: none"> 1. Check oil level, bleed cylinders, remove Contamination, replace oil seal 2. Check fitting, replace cylinder 3. Contaminated fluid, handle binds, clean valves 4. Clean check valve (replace if necessary) 5. Check all fittings and repair leaks
Lift Will Not Raise A Vehicle	<ol style="list-style-type: none"> 1. Low hydraulic fluid 2. Malfunction of pressure relief valve 3. Insufficient electrical voltage 4. Lift overload 5. Motor is running backwards 6. Air in hydraulic oil 7. Pump will not prime 8. Pump is damaged 9. Faulty lowering valve 	<ol style="list-style-type: none"> 1. Lower lift. Using ISO grade 32 hydraulic oil, fill the powerpack reservoir to 1" below the top 2. Clean pressure relief valve. if problem continues, call a service technician 3. Confirm a 208/230 volt power supply to the lift 4. Check that vehicle weight is evenly distributed And does not exceed rated capacity. 5. Confirm proper motor rotation - rewire if required 6. Check oil seal and bleed hydraulic system 7. Check hydraulic oil level and pick-up tube. Replace pump if required 8. Repair or replace pump 9. Clean or replace valve

Problem	Possible Causes	Solutions
Slow Drift Down	<ol style="list-style-type: none"> 1. Mechanical safety locks not engaged 2. Powerpack lowering valve contamination 3. Hydraulic system leaks 	<ol style="list-style-type: none"> 1. Raise lift to engage all safety locks then lower lift and confirm all safety locks are engaged 2. Back flush powerpack by opening manual over-right valve. Engage "up" switch and down lever at the same time and run approximately 10 seconds 3. Check cylinder and all fittings for any hydraulic oil leak

Replace all worn or broken parts and components only with manufacturer approved/supplied parts and components

Replacement parts may be purchased from your local lift supplier or the manufacturer at 1 - 877 - 799 - LIFT (5438) or (905) 847 - 1198

COATS®



Model:

4TLM6R4

6,000 lb. (2721 kg)

MID RISE

Lift Illustrations & Parts Lists

**for installation & service part reference
SAVE this MANUAL and ALL INSTRUCTIONS**

Total Automotive Lifting Solutions Inc.
2300 Speers Rd. Oakville, Ontario L6L 2X8
Phone: (905) 847-1198 Fax: (905) 891-1214
www.TLSLifts.com

Part Number : D-MR-06
Issue 002 Effective: April 15 , 2009
Supersedes Issue 002 - February 1 , 2009

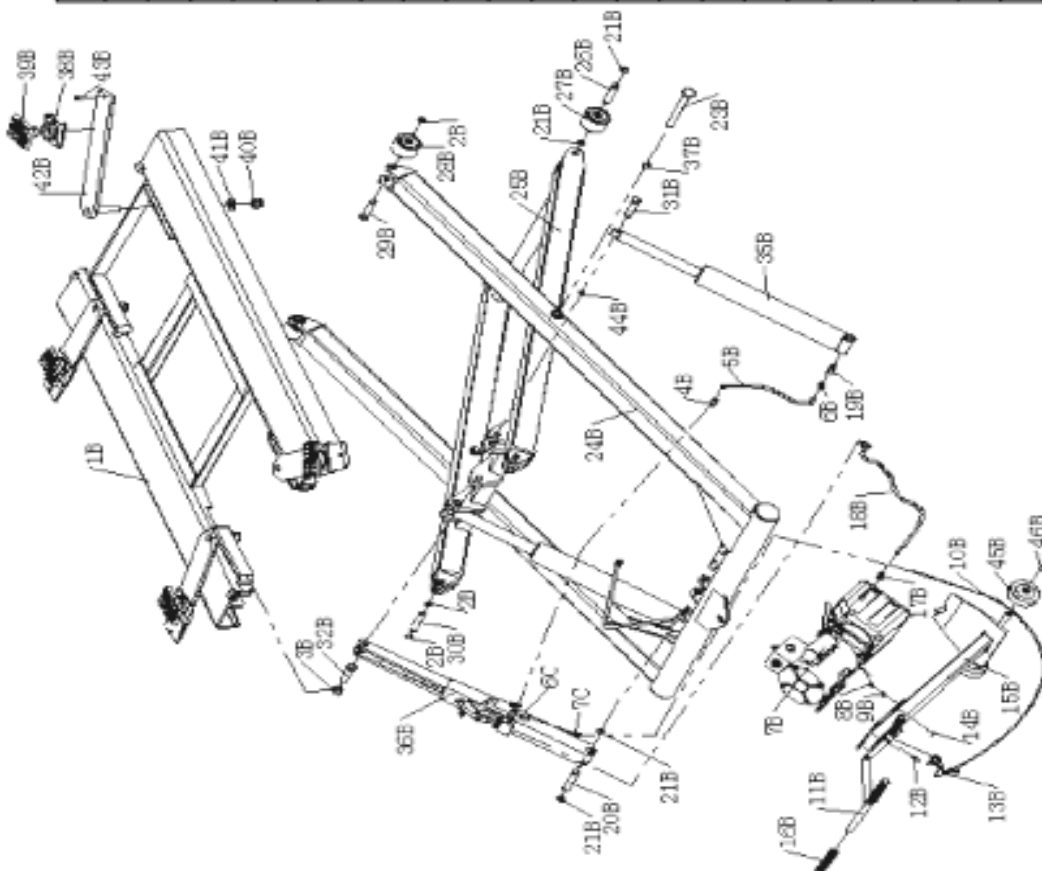

ITEM	DESCRIPTION	QTY
1B	Table	1
2B	Retaining ring	6
3B	Locking nut	1
4B	Oil pipe connector	3
5B	Branch inlet pipe	2
6B	Oil pipe connector	2
7B	Oil supply fitting	1
8B	Nut	4
9B	Washer	4
10B	Braque steel cable	1
11B	Handle	1
12B	Hex screw	4
13B	Brake brnb	1
14B	Bolt	4
15B	Transmission holder	1
16B	Rubber cap	1
17B	Oil pipe connector	1
18B	General inlet pipe	1
19B	Check valve	2
20B	Safety locking pin	1
21B	Retaining ring	6
23B	Scissor pin	2
24B	Scissor outside	1

ITEM	DESCRIPTION	QTY
25B	Scissor inside	1
26B	Wheel pin	2
27B	Big wheel	2
28B	Small wheel	2
29B	Wheel pin	2
30B	Conecion pin	2
31B	Cylinder pin	2
32B	Safety locking pin	1
33B	Bolt	1
34B	Nut	1
35B	Cylinder assembly	2
36B	Safety locking assembly	1
37B	Retaining ring	2
38B	Saddle holder	4
39B	Rubber saddle	4
40B	Locking nut	4
41B	Washer	4
42B	Plate	4
43B	Bolt	4
44B	Ring	2
45B	Wheel	2
46B	Nut	2

* Easily Worn Parts

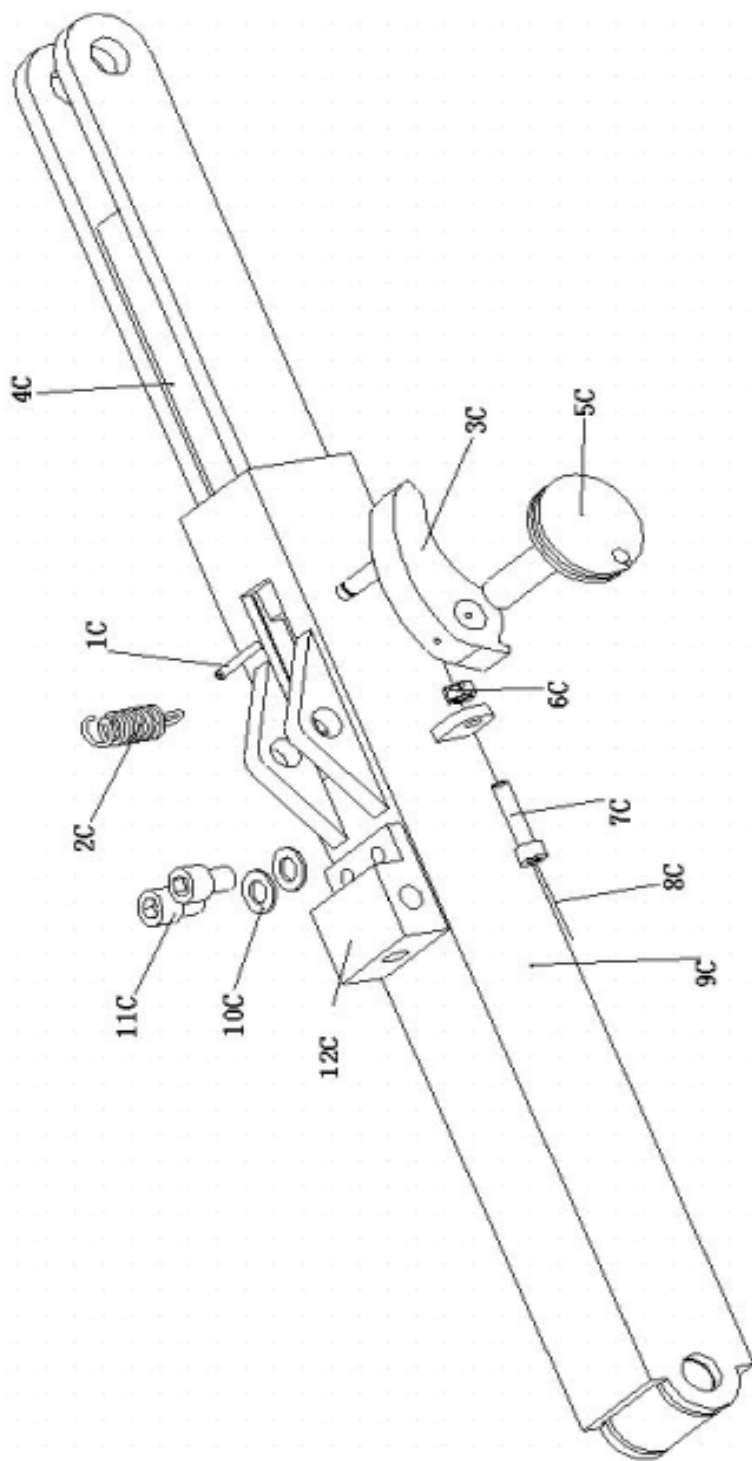

ITEM	DESCRIPTION	QTY
1C	Pin	1
2C	Spring	1
3C	Lock block	1
4C	Lock pole	3

* Easily Worm Parts

Spare Parts List

ITEM	DESCRIPTION	QTY
5C	Lock wheel	1
6C	Nut	1
7C	Bolt	1
8C	Steel wire cable	1

ITEM	DESCRIPTION	QTY
9C	Lock sheath	1
10C	Washer	1
11C	Bolt	1
12C	Check valve	1

