

COATS®

20,000 lb. (9,090 kg)

Two Post Lift

Medium Duty Commercial Lifts Capable of
Safely Servicing Vehicles Small and Large

4T220SSR1 (20,000 lb.)



#4T220SSR1

Installation Manual Operation Manual Service Parts Manual

READ the manual thoroughly before installing, operating, servicing, or maintaining the lift. SAVE this MANUAL and ALL INSTRUCTIONS.

1601 J.P. Hennessy Drive, LaVergne, TN 37086 (800) 688-6496 or (615) 641-7533

Hennessy Canada: 2430 Lucknow Drive, Unit 9, Mississauga, Ontario L5S 1V3 (905) 672-9440 www.coatsgarage.com
HENNESSY INDUSTRIES INC. Manufacturer of AMMCO®, COATS® and BADA® Automotive Service Equipment and Tools.

Manual Part No.: 85611160 00

Revision: 6/17

READ THIS MANUAL BEFORE INSTALLATION AND/OR OPERATION!

This is a vehicle lift operation manual and no attempt is made or implied herein to instruct the user in lifting methods to an individual application. Rather, the contents of this manual are intended as a basis for operation and maintenance of the lift as it stands alone or as it is intended and anticipated to be used in conjunction with other equipment.

Proper application of the equipment described herein is limited to the parameters detailed in the specifications and the uses set forth in the descriptive passages. The user assumes full responsibility for any equipment damage, personal injury or alteration of the equipment described in this manual or any subsequent damages.

Follow all safety, installation, operation, and maintenance instructions in this manual before installing and operating the lift. In addition, follow all safety and other information included on and with the lift before operating the lift. Keep this manual in a secure place for future reference, training and service part identification.

Insure this manual along with all operation, inspection and maintenance instructions are delivered to the owner/user/employer

WARNING:

Installation of equipment is hazardous. Only qualified personnel should perform installation procedures. Installers should familiarize themselves with equipment and installation procedure before attempting installation.

Decommission and disposal of product must be performed in accordance with local, state and/or federal regulations.

IMPORTANT

Owner/Employer Responsibility:

The Owner/Employer shall ensure that all lift operators are qualified and that they are trained in the safe use and operation of the lift using the manufacturer's operating instructions; ALI/SM 93-1, ALI SAFETY Tips card; ANSI/ALI ALOIM-1994, American National Standard for Automotive Lifts-Safety Requirements for Operation, Inspection and Maintenance; ALI/WL Series, ALI Uniform Warning Label Decals/Placards; and in the case of frame engaging lifts, ALI/LP-GUIDE, Vehicle Lifting Points/Quick Reference Guide for Frame Engaging Lifts.

The Owner/Employer shall establish procedures to periodically inspect the lift in accordance with the lift manufacturer's instructions and ANSI/ALI ALOIM-1994, American National Standard for Automotive Lifts-Safety Requirements for Operation, Inspection and Maintenance. The owner/employer shall also ensure that lift inspectors are qualified and that they are adequately trained in the inspection of the lift.

The Owner/Employer shall establish procedures to periodically maintain the lift in accordance with the lift manufacturer's instructions and ANSI/ALI ALOIM-1994, American National Standard for Automotive Lifts-Safety Requirements for Operation, Inspection and Maintenance. The owner/employer shall also ensure that lift maintenance personnel are **qualified** and that they **are adequately trained** by factory in the maintenance of the lift.

The Owner/Employer shall maintain the periodic inspection and maintenance records recommended by the manufacturer or ANSI/ALI ALOIM-1994, American National Standard for Automotive Lifts-Safety Requirements for Operation, Inspection and Maintenance.

The Owner/Employer shall display the lift manufacturer's operating instructions; ALI/SM 93-1, ALI Lifting it Right safety manual; ALI/ST-90 ALI Safety Tips card; ANSI/ALI ALOIM-1994, American National Standard for Automotive Lifts-Safety Requirements for Operation, Inspection and Maintenance; and in the case of frame engaging lifts, ALI/LP-GUIDE, Vehicle Lifting Points/Quick Reference Guide for Frame Engaging Lifts in a conspicuous location in the lift area convenient to the operator.

The Owner/Employer shall provide necessary lockout/tagout means for energy sources per ANSI Z244.1-1982 (R1993), Safety Requirements for the Lockout/Tagout of Energy Sources, before beginning any lift repairs.

The Owner/Employer shall not modify the lift in any manner without prior written consent of the manufacturer.

IMPORTANT SAFETY INSTRUCTIONS

When using your garage equipment, basic safety precautions should always be followed, including the following:

1. Read all instructions
2. Care must be taken as burns can result from touching hot parts
3. Do not operate equipment with a damaged cord or if equipment has been dropped or damaged – until it has been examined by a qualified service person
4. Do not let a cord hang over the edge of the table, bench, or counter or come in contact with hot manifolds or moving fan blades
5. If an extension cord is necessary, a cord with a current rating equal to or more than that of the equipment should be used. Cords rated for less current than the equipment may overheat. Care should be taken to arrange the cord so that it will not be tripped over or pulled
6. Always unplug equipment from electrical outlet when not in use. Never use the cord to pull the plug from the outlet. Grasp plug and pull to disconnect.
7. Let equipment cool completely before putting away. Loop cord loosely around equipment when storing
8. To reduce risk of fire, do not operate equipment in the vicinity of open containers of flammable liquids (gasoline)
9. Adequate ventilation should be provided when working on operating internal combustion engines
10. Keep hair, loose clothing, fingers, and all parts of body away from moving parts
11. To reduce the risk of electric shock, do not use on wet surfaces or expose to rain
12. Use only as directed in this manual. Use only manufacturer's recommended attachments
13. ALWAYS WEAR SAFETY GLASSES. Everyday eyeglasses only have impact resistant lenses, they are not safety glasses
14. To reduce the risk of injury, close supervision is necessary when this product will be used around children. (Pertains to cabinets only)
15. To reduce the risk of injury, never overload the drawers or shelves. Refer to markings for the proper load on receptacles.

SAVE THESE INSTRUCTIONS

AUTOMOTIVE LIFT

SAFETY INSTRUCTIONS

Please read and post these tips in a place where the operator will see and be constantly reminded of their importance.

REFER TO THE OPERATING, INSPECTION AND MAINTENANCE INSTRUCTIONS above.

1. When positioning vehicle, do not hit or run over lift arms, adapters or axle supports.
2. Remove passengers prior to raising vehicle. Never raise vehicle with anyone inside it.
3. Operating valves, switches and locking devices are designed for maximum safety. Never attempt to block open or override them.
4. Never overload your lift beyond stated lifting capacity.
5. Do not allow customers or by-standers to operate lift or to be in lift area during its operation.
6. Be sure work area around lift is clear - free of obstruction, debris, grease and oil.
7. Never attempt to operate a lift if it appears to be malfunctioning or if broken or damaged parts are evident.
8. Load lift carefully. Check to be sure the lifting pads are in secure contact with vehicle before raising to desired working height.
9. After lifting the vehicle to desired height, ALWAYS lower the unit onto the mechanical safety locks. The forming of good operational work habits will eliminate oversights in the use of provided safety devices.
10. Completely release locking devices before attempting to lower lift and stand clear while lowering.
11. Before removing vehicle from lift area, position arms, adapters or axle supports to assure that vehicle or lift will not be damaged.
12. Care must be taken as burns can occur from touching hot parts.
13. Do not operate equipment with a damaged power cord or if the equipment has been damaged in any way until it has been examined by a qualified serviceman.

**DO NOT LIFT VEHICLES OR OTHER
OBJECTS IN THIS MANNER.**

**FAILURE TO PLACE ALL FOUR ARMS
PROPERLY UNDER THE VEHICLE
MAY CAUSE STRUCTURAL DAMAGE
NOT COVERED UNDER WARRANTY.**

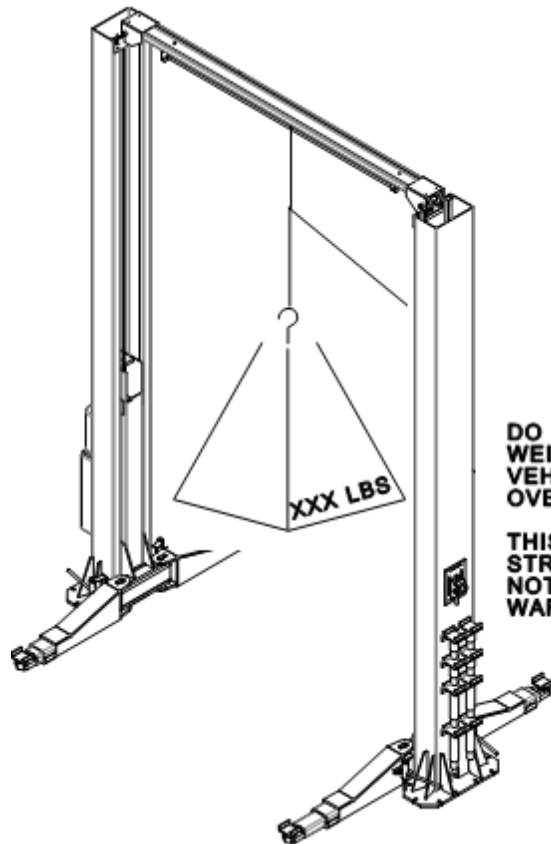
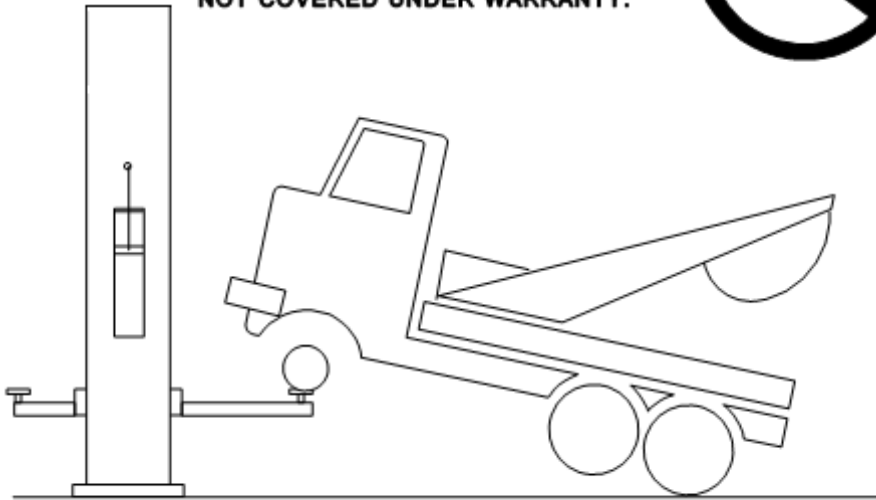

**DO NOT LIFT OR SUSPEND
WEIGHT, OBJECTS OR
VEHICLES FROM THE
OVERHEAD STRUCTURE.**

**THIS MAY CAUSE
STRUCTURAL DAMAGE
NOT COVERED UNDER
WARRANTY.**

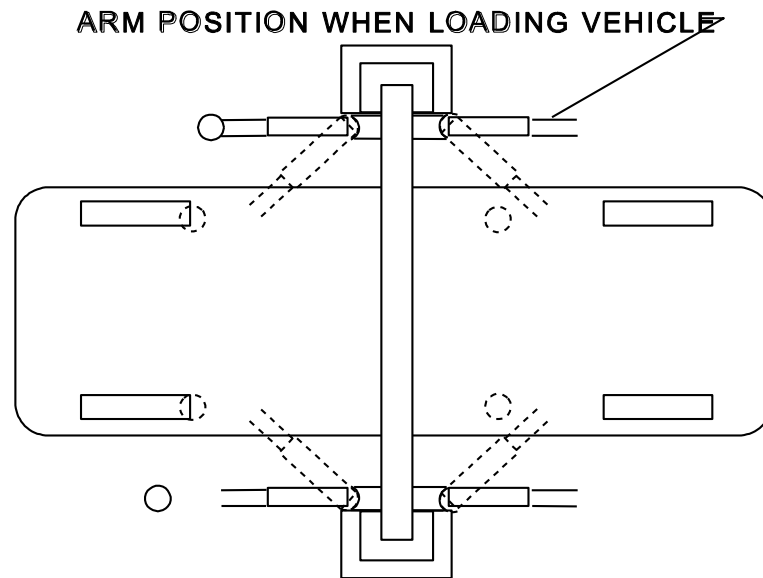

SPECIAL INSTRUCTIONS: - The lift is a two-post, frame engaging, surfaced mounted, 20,000 lbs. capacity lift. The intended use is to lift motor vehicles within the stated lifting capacity. For long wheelbase vehicles such as limousines, cargo vans, light trucks with toolboxes, extended and dual cab light trucks, etc.

1. Do not lift without first finding the vehicle's center of gravity.
2. Do not exceed the stated capacity of the lift.
3. Do not operate the lift if the load is not stable.
4. Observe overhead clearance for obstructions when lifting light trucks with ladder racks, cranes, campers, etc.
5. Always use all four arms when lifting a vehicle and follow the vehicle manufacturer's guide lines for recommended lifting points.
6. Height extenders may be needed for proper frame engagement when lifting light trucks and vans.
7. Do not use wood, bricks, homemade extenders, etc. Use extenders manufactured for specific use with the lift.

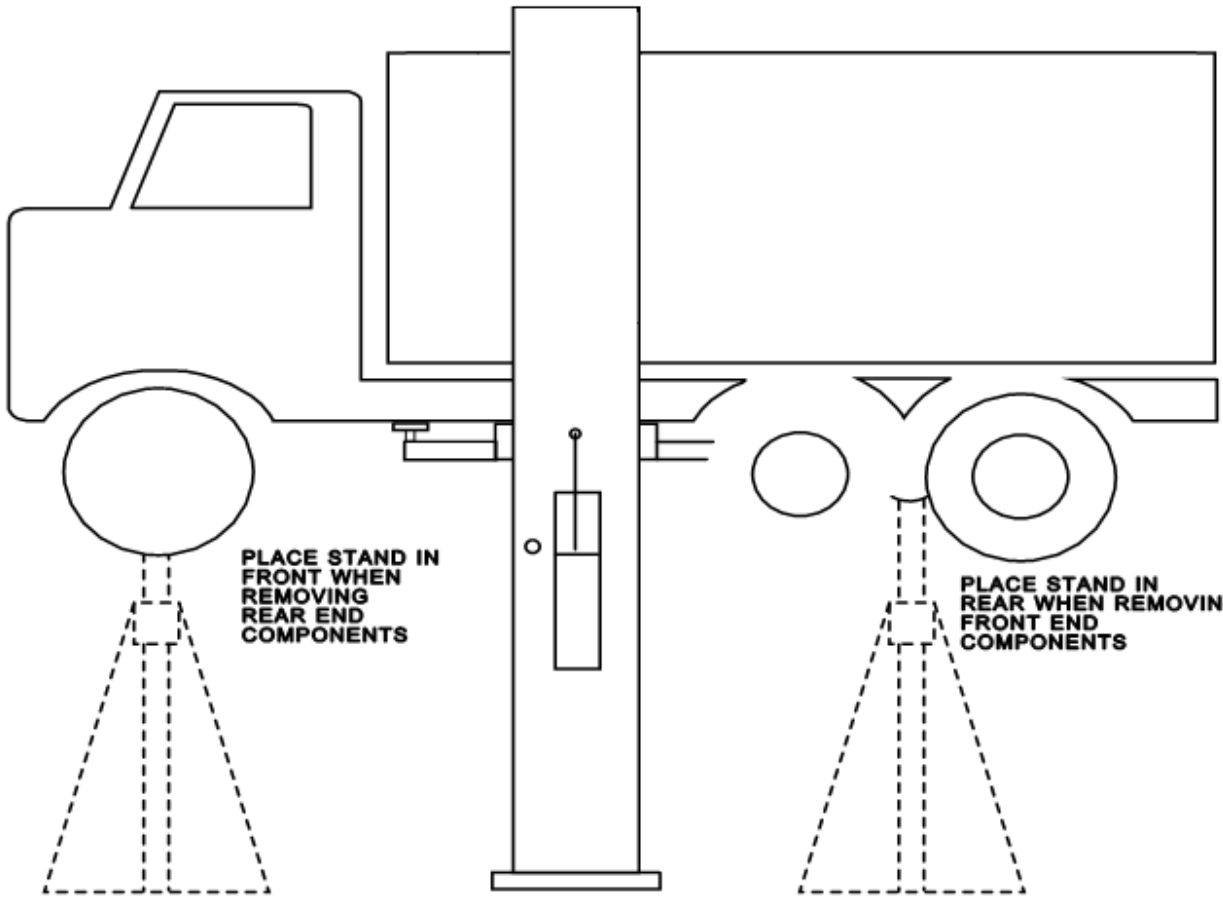

CAUTION: SHOULD ANY SIGNIFICANT WEIGHT COMPONENT BE REMOVED OR ADDED AFTER THE VEHICLE IS RAISED, USE JACK STAND(S) TO SUPPORT THE OVER BALANCED END AS SHOWN IN THE FIGURE ABOVE.

IMPORTANT WARNINGS:

1. Do not operate the lift unless safety locks are functioning properly as evidenced by all safety locks dropping into the safety ladder slots when raising the carriages.
2. Do not operate the lift if the load tilts or binds during the up or down movement.
3. Always use all four arms when lifting a vehicle and follow vehicle manufacturer's guide lines for recommended lifting points.

INSPECTION AND MAINTENANCE PROCEDURES

This schedule is based on conditions found in the usual automotive service environment under normal usage (approximately 1200 cycles per year). In cases of high volume operation or areas with a high density of airborne debris, the schedule must be accelerated.

The maintenance is to be performed by factory trained lift service personnel only.

1. SAFETY LATCH WORKING / CHECK DAILY / ADJUST CABLE TENSION IF OUT OF SYNCHRONIZATION.
2. ARM PINS / CHECK SEMI-ANNUALLY / LUBE EVERY 6 MONTHS WITH GREASE.
3. LIFT ADAPTERS, REPLACE IF DAMAGED
4. ARM RESTRAINT RODS / CHECK MONTHLY / KEEP THREADS CLEAN AND RUST FREE.
5. SPINDLE PADS / CHECK MONTHLY / KEEP THREADS CLEAN AND RUST FREE. USE LIGHT OIL TO LUBRICATE.
6. COLUMN ANCHOR BOLTS / CHECK QUARTERLY / CHECK WEEKLY IN THE FIRST MONTH OF OPERATION, MIN 110 FT. LBS. OF TORQUE. IF UNABLE TO TIGHTEN STOP USING THE LIFT AND CONTACT INSTALLER.
7. FLOOR CRACKS EMULATING FROM UNDER COLUMNS / CONTACT INSTALLER
8. STRUCTURAL WEAR, CRACKS OR VISUALLY OUT OF PLUMB / CONTACT FACTORY
9. EQUALIZATION CABLE / CHECK SEMI-ANNUALLY / SEE FOLLOWING PAGE FOR INSPECTION PROCEDURE.
10. CARRIAGE BEARINGS / CHECK SEMI-ANNUALLY / GREASE WITH LITHIUM RP #2. REPLACE BEARINGS WHEN CLEARANCE BETWEEN BEARING MOUNTING PLATES AND COLUMN IS LESS THAN 1/16".
11. HYDRAULIC FLUID / REPLACE EVERY TWO YEARS WITH ISO 32 OR EQUAL.

Call factory for technical assistance if lift becomes inoperative in the raised position.

Replace all worn or broken parts and components only with manufacturer approved/supplied parts and components

Replacement parts may be purchased from your local lift supplier or the manufacturer at: 1-877-799-LIFT (5438) or (905) 847-1198

EQUALIZATION CABLE INSPECTION

Without load on the arms raise the carriages in increments that will allow inspection of the entire cable. If the following conditions exist replace the cable:

1. When its diameter is less than 1 1/32".
2. If 3 or more element wires are broken in 1 strand.
3. If 6 or more element wires are broken in a strand lay.
4. Badly deformed or rusted.
5. Broken wires at the connection to threaded rods.

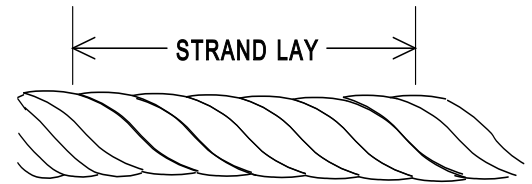

Inspect the lower column and vertical profile pulleys for broken excessive wear in the groove, bushing or axle. Annually lubricate the entire cable with light oil.

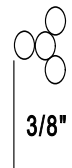

flanges,

If any of the cable is as shown in the following pictures, do not use.

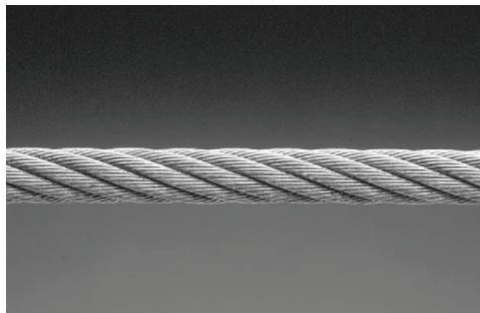

Typical Good Cable

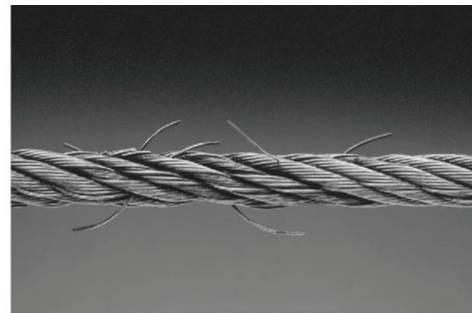

Cable With Broken Wires

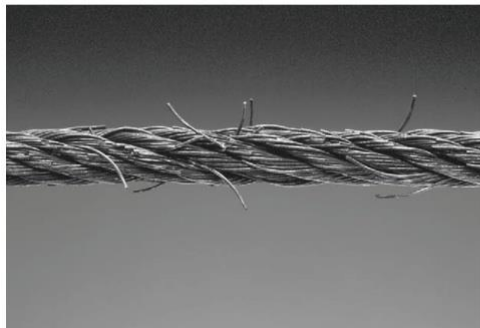

Cable With Severe Corrosion

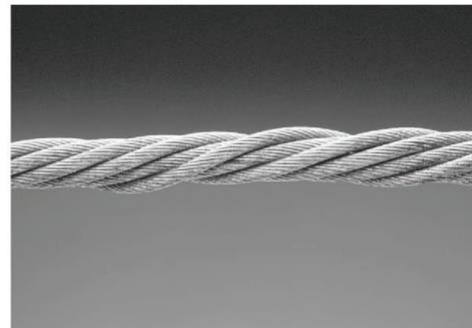

Cable With Necking

TROUBLESHOOTING GUIDE

The following are suggestions to consider if you have problems with the lift. Please call a qualified lift technician and/or a qualified electrician for further clarification and information.

Problem	Possible Causes	Solution
Lift Will Not Raise or Lower	<ol style="list-style-type: none"> 1. Blown fuse or circuit breaker 2. Tripped thermal overload 3. Incorrect voltage to motor 4. Bad wiring connections 5. "UP" switch burned out 6. Motor windings burned out 	<ol style="list-style-type: none"> 1. Replace fuse or reset/replace circuit breaker 2. Reset thermal overload 3. Supply correct voltage to motor 4. Repair and insulate all connections 5. Replace switch 6. Replace motor
Lift Will Not Raise	<ol style="list-style-type: none"> 1. Air in oil or low oil level 2. Lowering Valve leaks 3. Motor runs backward 4. Pump damaged 5. Pump will not prime 6. Relief Valve leaks 7. Voltage to motor incorrect 8. Lift overloaded 	<ol style="list-style-type: none"> 1. Check fluid level, oil seal, bleed system 2. Clean valve or replace 3. Check for correct wiring 4. Repair or replace pump 5. Check fluid level and pick-up tube - replace pump 6. Clean Relief Valve (replace if necessary) 7. Supply correct voltage to motor 8. Verify that loaded vehicle weight does not exceed rated lift capacity
Lift Will Not Lower	<ol style="list-style-type: none"> 1. Mechanical locks are engaged 2. Obstruction under lift or in glide block tracks 3. Faulty lowering solenoid valve 	<ol style="list-style-type: none"> 1. Raise unit slightly and disengage mechanical locks 2. Carefully remove obstruction - clean glide block tracks 3. Replace valve
Lift Will Not Hold Pressure	<ol style="list-style-type: none"> 1. Contamination in system 2. Internal Cylinder leaks 3. Lowering Valve leaks 4. Check Valve leaks 5. External leaks 	<ol style="list-style-type: none"> 1. Check oil level - bleed cylinders - remove contamination - replace oil seal 2. Check fitting, replace cylinder 3. Contaminated fluid, handle binds, clean valves 4. Clean check valve (replace if necessary) 5. Check all fittings and repair leaks
Lift Will Not Raise A Vehicle	<ol style="list-style-type: none"> 1. Low hydraulic fluid 2. Malfunction of pressure relief valve 3. Insufficient electrical voltage 4. Lift overload 5. Motor is running backwards 6. Air in hydraulic oil 7. Pump will not prime 8. Pump is damaged 9. Faulty lowering valve 	<ol style="list-style-type: none"> 1. Lower lift. Using ISO grade 32 hydraulic oil, fill the powerpack reservoir to 1" below the top 2. Clean pressure relief valve. if problem continues, call a service technician 3. Confirm a 208/230 volt power supply to the lift 4. Check that vehicle weight is evenly distributed and does not exceed rated capacity. 5. Confirm proper motor rotation - rewire if required 6. Check oil seal and bleed hydraulic system 7. Check hydraulic oil level and pick-up tube. Replace pump if required 8. Repair or replace pump 9. Clean or replace valve

Problem	Possible Causes	Solutions
Slow Drift Down	<ol style="list-style-type: none"> 1. Mechanical safety locks not engaged 2. Powerpack lowering valve contamination 3. Hydraulic system leaks 	<ol style="list-style-type: none"> 1. Raise lift to engage all safety locks then lower lift and confirm all safety locks are engaged 2. Back flush powerpack by opening manual over-right valve. Engage "up" switch and down lever at the same time and run approximately 10 seconds 3. Check cylinder and all fittings for any hydraulic oil leak
Lift Going Up Out of Level	<ol style="list-style-type: none"> 1. Lift installed on un-level floor 2. Cable(s) out of adjustment 	<ol style="list-style-type: none"> 1. Reinstall on level surface 2. re-adjust cables - Call service technician if problem persists
Anchors Will Not Stay Tight	<ol style="list-style-type: none"> 1. Holes drilled oversize 2. Concrete floor thickness or holding strength not sufficient 	<ol style="list-style-type: none"> 1. Relocate lift using the correct bit to drill holes 2. Break out old concrete and re-pour new foundation per lift installation instruction

Call factory for technical assistance if lift becomes inoperative in the raised position, and the maximum operating hydraulic pressure developed upon lifting the rated capacity.

Replace all worn or broken parts and components only with manufacturer approved/supplied parts and components

Replacement parts may be purchased from your local lift supplier or the manufacturer at: 1-877-799-LIFT(5438) or (905) 847-1198

IMPORTANT NOTICE!!

The floor on which the lift is to be installed must be a minimum thickness of 4" reinforced concrete with a minimum compressive strength of 4000 PSI. Lift should only be installed on level concrete floors with no more than 3° of slope.

Failure by the purchaser to provide the recommended mounting surface could result in unsatisfactory lift performance, property damage and/or personal injury.

A qualified person should be consulted to address seismic loads and other local or state requirements.

The lift is approved only for indoor use. Do not install the lift outdoors!

LIFT SPECIFICATIONS

20,000 lb. Capacity

Lowered Height - Standard Lift Pad:	5"
Raised Height - Standard Lift Pad:	76"
Raised Height with extended adapters:	85"
Lift Time:	70s
Shipping Weight:	3,500 lbs.
Concrete:	Min. 4", 4000 psi, aged for 30 days.
Electrical:	230V - 1 ph - 60 Hz - 25 A
AIR:	100 psi

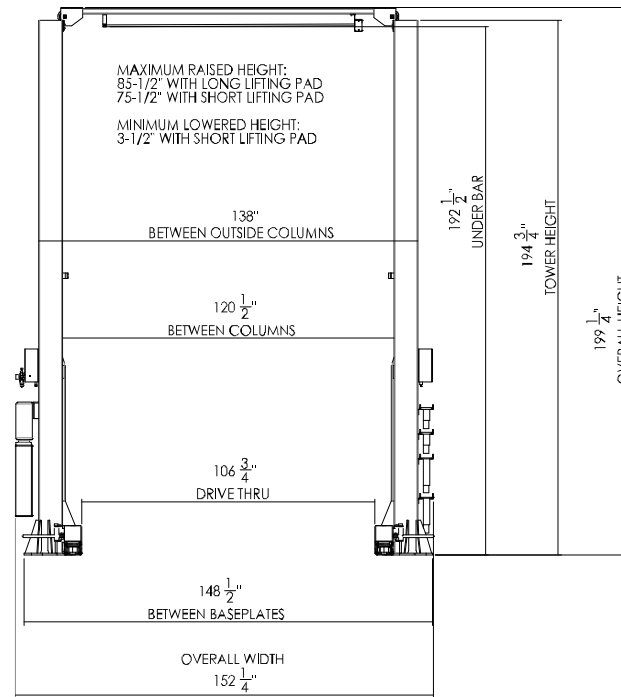
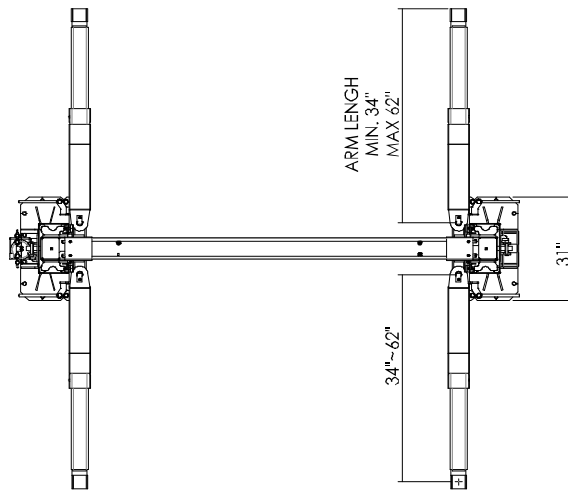

BAY DIMENSION REQUIREMENT

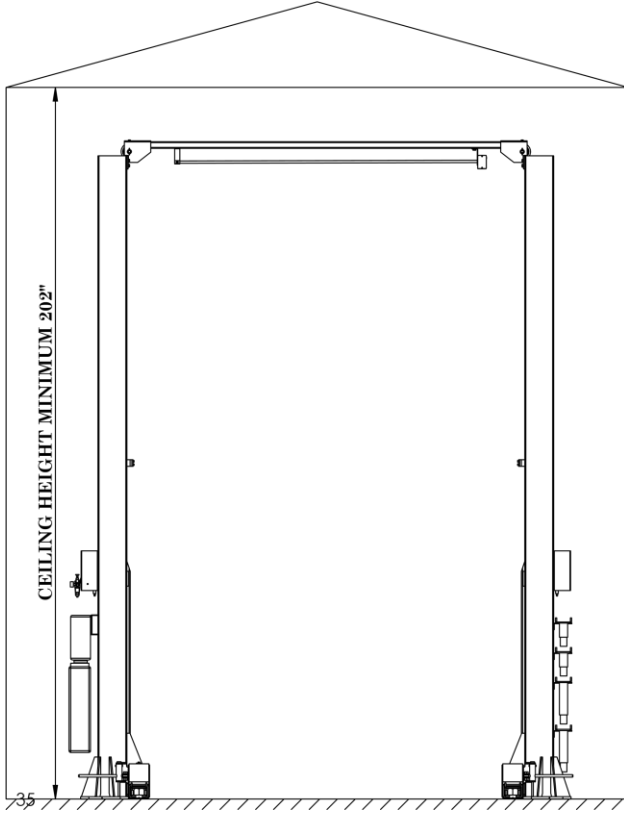
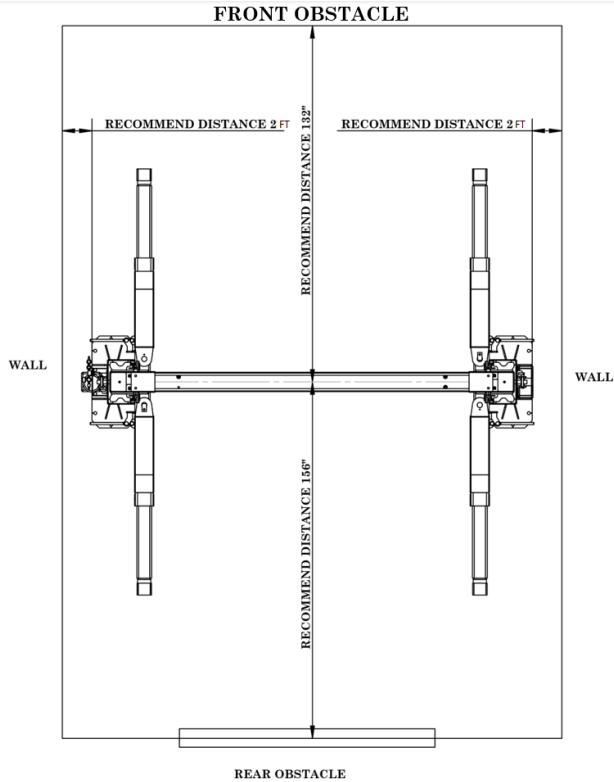

LIFT PACKAGE CONTENTS

Main Components include:

Columns assembly – 2 pc (one power side column, one non-power side column)
Arm Assemblies – 4 pc
Crossmembers Assembly – 1 pc
Accessories (see list below)

Accessory includes:

Powerpack – 1 pc
Lift Equalizing Cables – 2 pc
Hydraulic Hose – 3 pc
Air Cylinder – 2 pc
Air Line – 3 pc
Arm pin – 4 pc
Micro-switch for overhead shutoff bar (c/w mounting brackets and hardware)
3" Lifting Adapter – 4 pc
7" Lifting Adapter – 4 pc
12" Lifting Adapter – 4 pc
Adapter holder (brackets) – 4 pc
Overhead Safety Bar – 1 pc
Overhead Safety Bar Foam – 1 pc
Safety Lock Cover – 2 pc
WL 200 Series Safety Information Label Kit
ALI - "Lifting It Right" Manual
ALI - "Vehicle Manufacturer's Lifting Point Guide" (CD)
Automotive Lift Safety Tips Hang Card
Automotive Lift, Operation, Inspection and Maintenance Manual
Owner's Manual

Hardware Box includes: Fittings, bolts, washers, nuts, anchor bolts, etc.

GENERAL TOOLS FOR INSTALLATION:

Rotary hammer drill with 3/4" solid drill bit with carbide tip
4' Level
Hand Sledge
Pry Bar
Tape Measure
Chalk line
12' Ladder
Shortened 1/16" open-end Wrench
Vise Grips
Snap Ring Pliers
11/16" Open End Wrench

5/8" Open End Wrench
9/16" Socket and suitable ratchet
1/2" Socket and suitable ratchet
1 1/8" Deep Socket and suitable ratchet
4 Gal. Hydraulic fluid – ISO 32 or equivalent

LIFT INSTALLATION MANUAL

Insure the lift installation complies with ANSI/ALI ALIS, Safety Requirements for Installation and Service of Automotive Lifts.

COLUMN PLACEMENT

1. Placement of lift should be at least 12' from nearest obstacle, front to rear, plus any desired aisle or work area between vehicle and obstacle such as garage door, work bench, etc. Place a chalk line at the selected location, erect both columns in their respective locations outside baseplate to baseplate and square to chalk line. The control column may be placed on either side. (See Fig. 1).
2. Beginning with the control column, manually raise the carriage to the 2nd safety catch and stop. Drill holes and install concrete anchor bolts, but **DO NOT TIGHTEN** until column has been leveled, shim if necessary. If shims exceed 1/2", contact factory. Tighten anchor bolts a min. of 110 Ft. Lbs. **DO NOT INSTALL** anchor bolts for opposite control column at this time.
3. **VERTICAL AND HORIZONTAL PROFILE INSTALLATION** (See Fig. 2)
Place the horizontal profile (crossbeam) on the top of the towers by using the hooks on the ends of the crossbeam. Install the 1/2"x 1-1/2" bolts with flat washers, lock washers and nuts in the 4 holes. **DO NOT TIGHTEN BOLTS AT THIS TIME**. Install remaining vertical profile on opposite column. **DO NOT** tighten profile bolts at this time.
4. Confirm correct column placement dimension (See Fig. 1).
5. Manually raise the opposite control column carriage as described in step 2. **NOTE:** Both carriages must be at the same height. Drill holes and install concrete anchor bolts. Level with shims if necessary. Tighten anchor bolts.
6. Tighten all overhead vertical and horizontal profile bolts.
7. **CABLE INSTALLATION**
Confirm that both carriages are of equal height. Stand facing the carriage of the control column. Beginning with the short-threaded cable rod, run the cable up and over the vertical profile pulley, through the horizontal profile to the opposite column, down through the carriage, around the bottom column pulley and up through hole in the bottom of the carriage. The bottom column pulley must be removed and replaced. Continue to run the cable up and out the top of the carriage. Thread the 3/4 x 10 nut all the way on the short threaded rod. Pull the cable with the short rod back down to its normal position. Insert the long threaded rod through hole on top of carriage and thread 3/4 x 10 nut on by hand as far as possible. **DO NOT** tighten at this time. Repeat the above for 2nd cable. To complete tightening of the cables places a vise grip at least 6" above the 3/4 x 10 nut on the long-threaded rod and a 1 1/16" wrench on the 3/4 x 10 nut. Turn the rod with the vise grip to thread nut on rod. Tighten each cable until approximately 1/2" deflection is

present midpoint in the cable. If both safety latches fall in at the same time once the lift is operated up; no further cable adjustment is needed.

8. HYDRAULIC PIPES & AIR LINE (See Diagram 9 & 10)

Mount power unit to studs on the control column. Install the male elbow hydraulic fitting into the power. Connect the short flexible hydraulic hose to the fitting on the power unit. Connect the short hydraulic hose to the T fitting. Then connect the longer hose to the T fitting and the cylinder on the control side. Connect the other long flexible hydraulic hose to the T fitting. Then run the hose to the cylinder on the other side through the overhead cross beam and adapter brackets on the tower. Connect the hose to the cylinder. Tighten all fittings. Check the hose in the cross beam to make sure it is clear with the equalizing cables. Fill the oil tank with ISO 32 hydraulic fluid (15 liters).

Install the air valve with the pre-assembled air fittings into the bracket near the safety lock at both towers. Connect the 2 pre-assembled air hoses. Connect the 5/32 air hose (in hardware kit) to the 90-degree fitting on the air valve.

The input air should be clean, dry, regulated system and a min. of 75 PSI and a maximum not to exceed 100 PSI.

9. LIFT ARMS

Each lift arm has an eyebolt bracket for the threaded eyebolt. This bracket should correspond with the arm restraint device located on the side of the carriage. Grease and install arm axles. Insert the threaded eyebolt into arm-restraint device by pushing up on the arm-restraint contact pin line up eyebolt hole with bracket on arm and insert the 3/4 x 3" bolt from the top, secure with 3/4" nylock nut (See Fig. 3).

10. Establish electrical power 220 Volt, Single Phase. Use 10 gage. wire with 2 poles 30 amp breaker.

11. SAFETY OVERHEAD BAR

Attach micro switch to overhead safety bar bracket on power pack side of overhead cross-member. Wire power pack to shop electrical system by a **certified electrician**.

12. Operate the lift to full height.

To lower, depress the air valve palm button on the column and the hydraulic release lever on the pump. Raise and lower lift in full stroke for several times, then check the following:

- a) Both safety latches fall in at the same time.
- b) Both safety latches release properly.
- c) Hydraulic leaks.
- d) Arm - restraint function properly.
- e) Anchor bolt and all other nuts and bolts are tight.
- f) Safety Limit functions properly.

LIFT OPERATION:

Before lifting a vehicle, insure all operators are qualified, have been trained and are following all safety instructions. Read and follow the ALI "Lifting It Right" manual included with the lift. Always use the "Vehicle Lifting Points" reference guide when lifting a. Insure all materials stay up to date »» www.autolift.org/ (see example of SAE J2184 standard below)

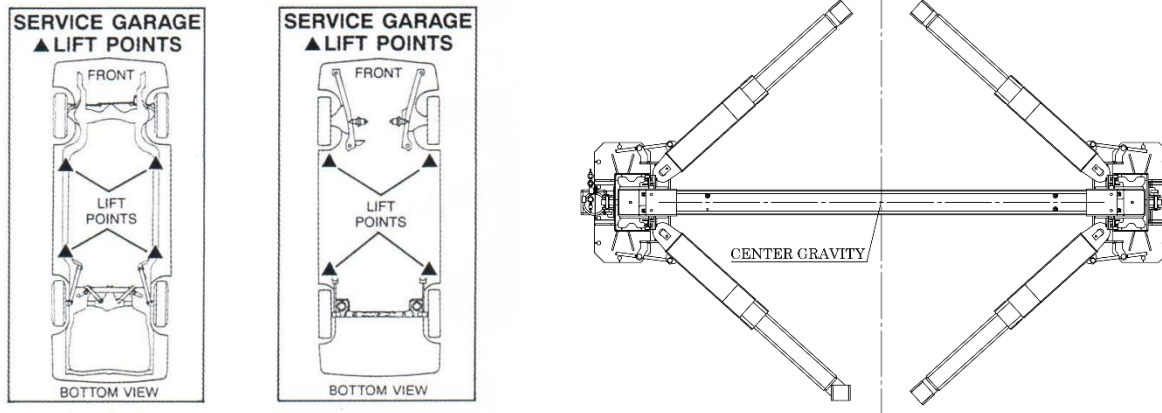

Typical Label Drawings

Reprinted with permission from SAE J2184

©2007 Society of Automotive Engineers, Inc.

Insure the vehicle is securely positioned on the lift using manufacturer's recommended lifting points. Insure all arm restraints are totally engaged. Never allow anyone under the lift when raising or lowering it with or without a vehicle. Always confirm safety locks on both sides of the lift are completely engaged before proceeding under a vehicle.

Lift electrical operating controls are located on the powerpack (one "up" button for raising the lift and one "down" lever for lowering the lift). Before lowering, slightly raise the lifting carriages to release pressure from both safety locks. Two hands must be used when lowering the lift. One hand must operate the safety lock release lever (located on the column above the powerpack) and one hand must operate the "down" lever. Make certain the safety locks do not accidentally re-engage while lift is being lowered. Customers and bystanders should not be in the lift area.

Important: Regularly inspect the hydraulic pressure developed upon the rated capacity, and make sure the pressure doesn't exceed the operating pressure (2,600 psi), as per ANSI/ALI ALCTV: 2017.

LIFT OPERATIONAL TEST WITH A TYPICAL VEHICLE:

To Raise Vehicle:

1. Lower carriages to the floor position.
2. Retract lifting arms to minimum length.
3. Swing arms away from the path of the vehicle. Before spotting the vehicle, consult "Quick Reference Guide, Vehicle Lifting Points for Frame Engaging Lifts" (ALI/LP-Guide).
4. During loading or spotting, center the vehicle between the columns as shown in figure above. Also see "Spotting the Vehicle and The Center of Gravity" in the "LIFT IT RIGHT" safety manual.
5. Swing arms under the vehicle. Position the vehicle support pads at the VEHICLE MANUFACTURER'S RECOMMENDED LIFTING POINTS. Beginning with some 1994 year models, auto makers will identify recommended lift points by placing a label on the vertical lock face plate of the front passenger side door. (ANSI/SAE J2184-OCT92)
6. Clear area around the lift.
7. Raise the vehicle until the vehicle support pads are in full contact, approximately 12 inches off floor. Check to see that vehicle is stable on the lift by moderately rocking the bumper. Recheck the position of the pads for any movement.
8. Raise the vehicle to the desired working elevation and release control button.
9. Lower lifting carriages until they completely contact the mechanical safety locks. The vehicle is now ready for service.

To Lower Vehicle:

1. Clear area around and under the lift of obstructions and warn personnel to stand clear.
2. Raise vehicle by at least 3 inches to clear the safety latches.
3. Press air switch to release safety lock and pull release lever.
4. No one must be under the vehicle when lowering as the safety locks are not engaged.
5. Lower the lift until arms have bottomed and are clear of the lifting points.
6. Swing the lifting arms from beneath the vehicle and fully retract the arms.
7. Remove the vehicle.

To Load an unusual Vehicle:

Call factory for technical support with vehicle spec before loading.

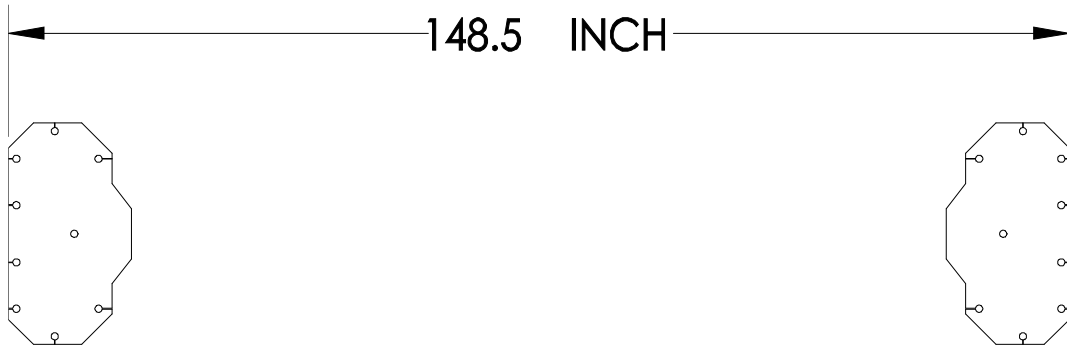

FIG. 1

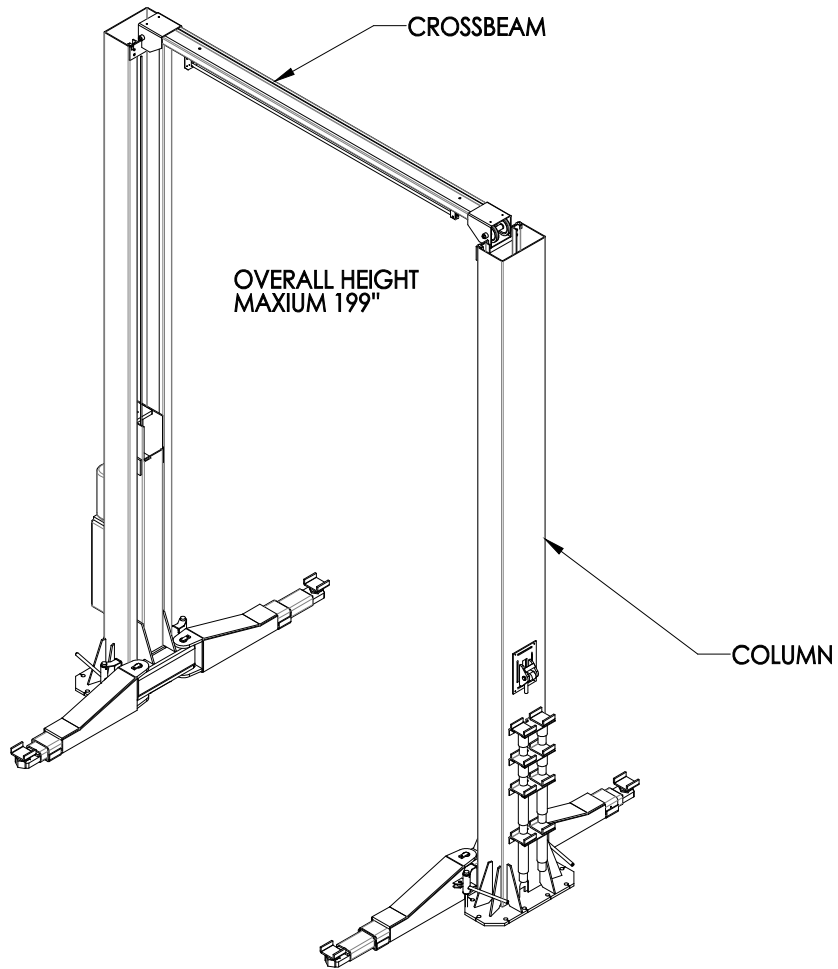

FIG. 2

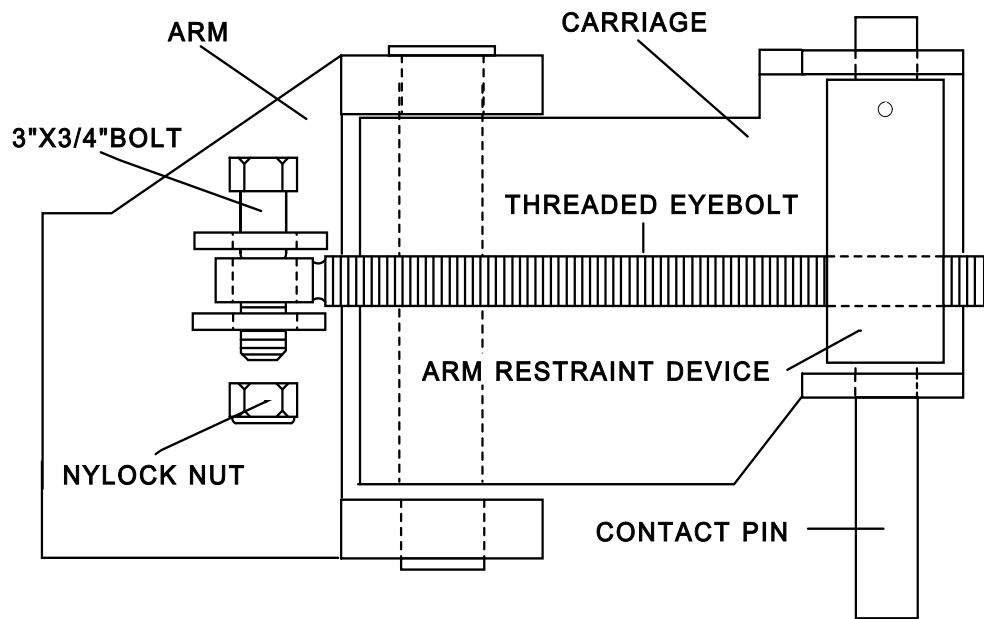

FIG. 3

LIFT ILLUSTRATIONS and PARTS LISTS

The diagrams below identify the main components and the order in which they are to be installed. Numbers correspond to installation diagrams found in the chart below and on following pages. Page numbers for each diagram is also found in the chart below. These diagrams, along with related parts lists, will assist you when installing and servicing this lift. Please insure these lift diagrams and parts lists are kept in a secure place for quick reference.

Diagram #1: LIFT ASSEMBLY	24
Diagram #2: TOWER ASSEMBLY.....	25
Diagram #3: OVERHEAD CROSSBEAM ASSEMBLY.....	27
Diagram #4: TOWER, CARRIAGE AND ARM ASSEMBLY.....	28
Diagram #5: ARM LOCK ASSEMBLY	29
Diagram #6: EQUALIZING CABLES	31
Diagram #7: ARM ASSEMBLY	32
Diagram #8: ANCHOR BOLTS.....	33
Diagram #9: HYDRAULIC SYSTEM	34
Diagram #10: AIR LINE	35
Diagram #11: POWER UNIT MOUNTING.....	36
Diagram #12: POWER UNIT WIRING DIAGRAM.....	37
Diagram #13: SAFETY INSTRUCTIONS	38

Diagram #1: LIFT ASSEMBLY

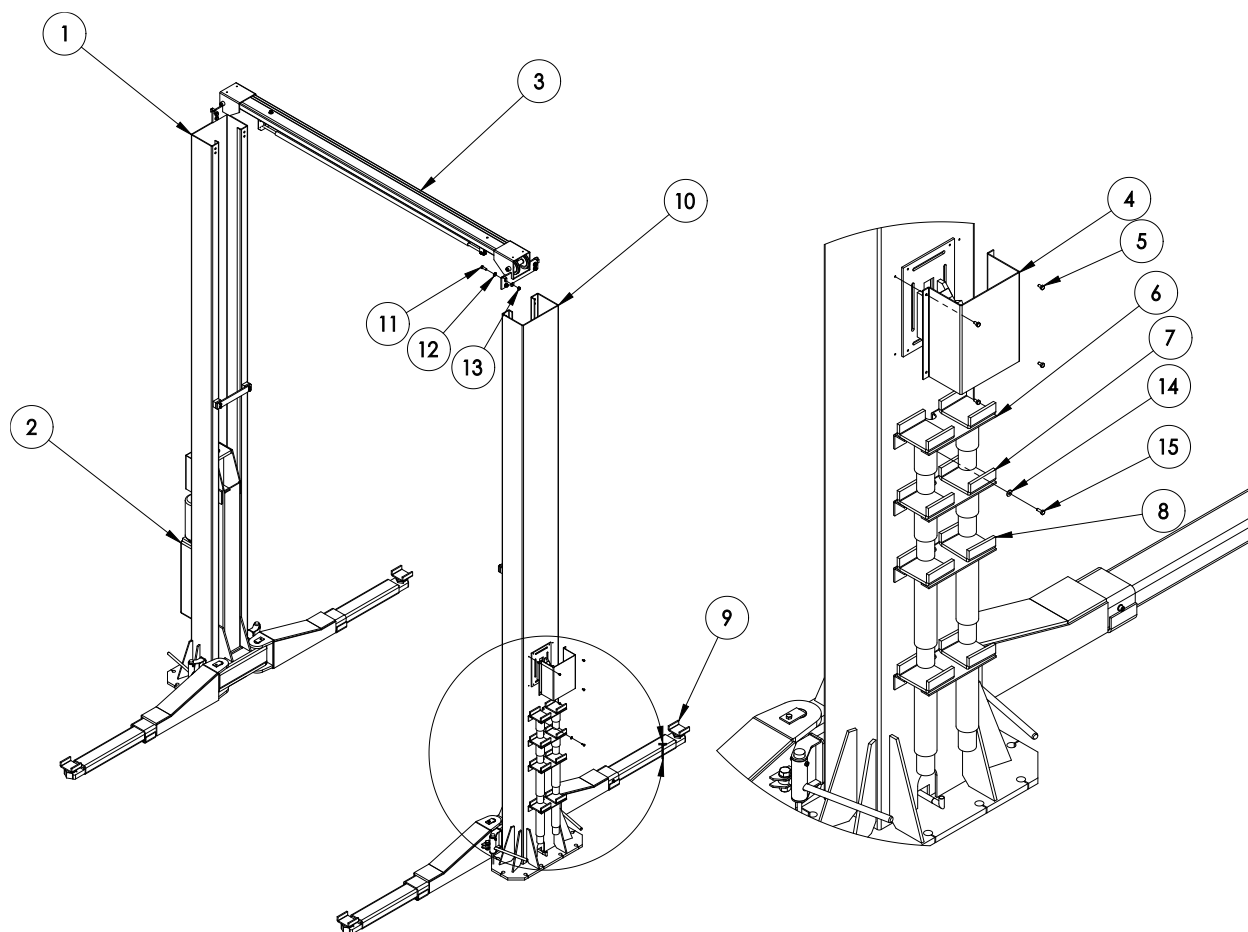

ITEM NO.	PART NUMBER	DESCRIPTION	QTY.
1	42160005	TOWER (POWER SIDE)	1
2	32160009	POWER PACK	1
3	42160004	OVERHEAD CROSSBEAM ASSEMBLY	1
4	12160129	SAFETY COVER	2
5	3C000151	HEX BOLT	4
6	12160123	ADAPTER BRACKET W/ 3/8" BOLTS	4
7	22160022	7" ADAPTER	4
8	22160008	12" ADAPTER	4
9	22160007	3" ADAPTER	4
10	42160011	TOWER (NON-POWER SIDE)	1
11	3C000149	1/2"x1.5 BOLT	8
12	3C000129	1/2" FLAT WASHER	16
13	3C000150	1/2" HEX NUT	8
14	3C000180	1/4" FLAT WASHER	8
15	3C000181	1/4" BOLT	8

Diagram #2: TOWER ASSEMBLY

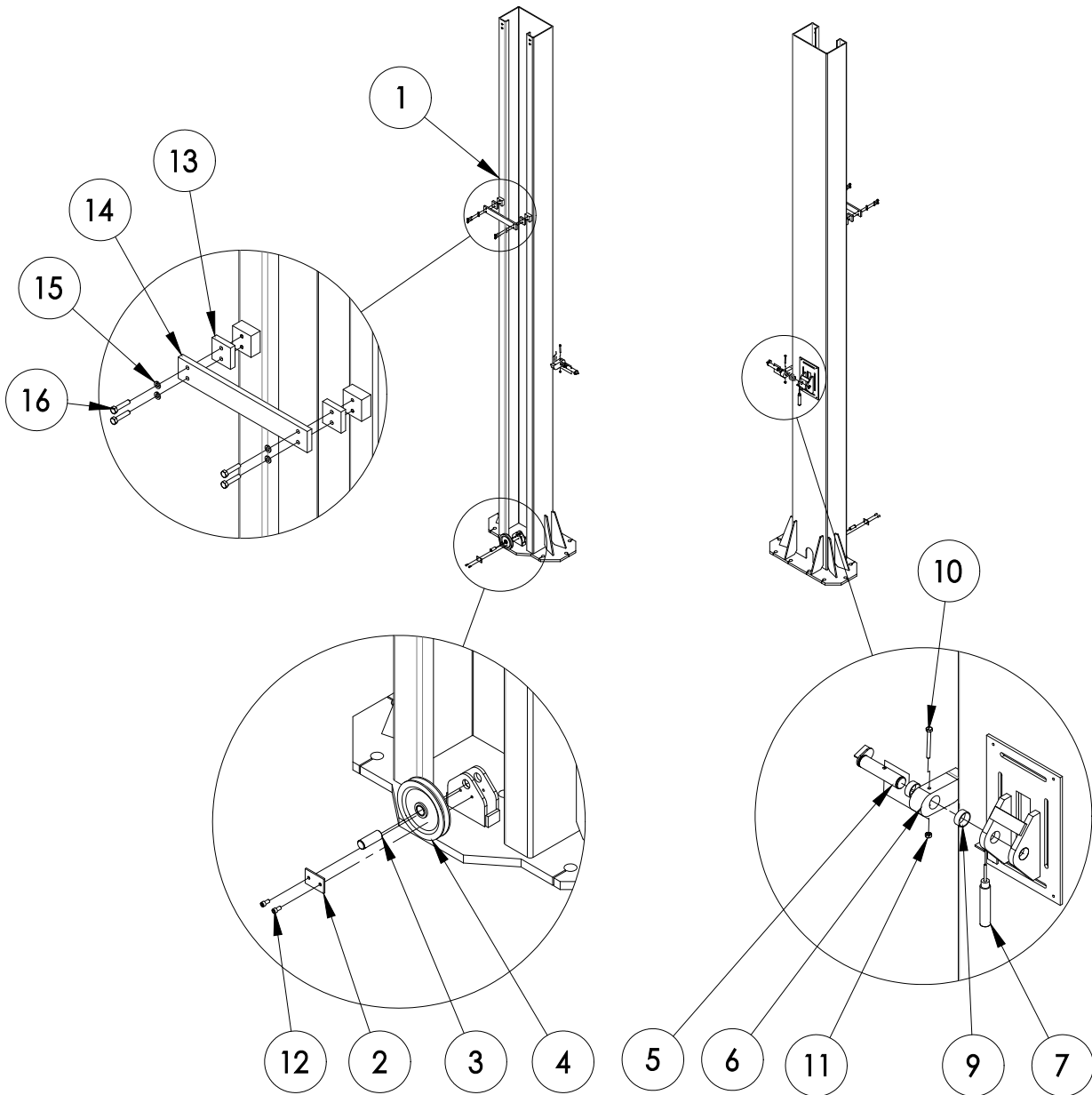

ITEM NO.	PART NUMBER	DESCRIPTION	QTY.
1	22160017	TOWER WELDMENT	2
2	12160055	SHAFT FIX CLIP	2
3	12160054	PULLEY SHAFT	2
4	42160007	PULLEY W/ BUSHING	6
5	22160016	SAFETY LOCK SHAFT	2
6	12160085	SAFETY LOCK	2
7	32160008	BIMBA AIR CYLINDER 1" STROKE	4
9	12160112	SPACER	2
10	3C000154	1/4"X2.5" HEX BOLT	2
11	3C000147	1/4" HEX NUT	2
12	3C000133	1/4"X1/2" SOCKET SCREW	4
13	12160137	BRACE BAR SPACER	4
14	12160138	BRACE BAR	2
15	3C000000	5/16" LOCK WASHER	8
16	3C000155	5/16"X1.5" HEX BOLT	8

Diagram #3: OVERHEAD CROSSBEAM ASSEMBLY

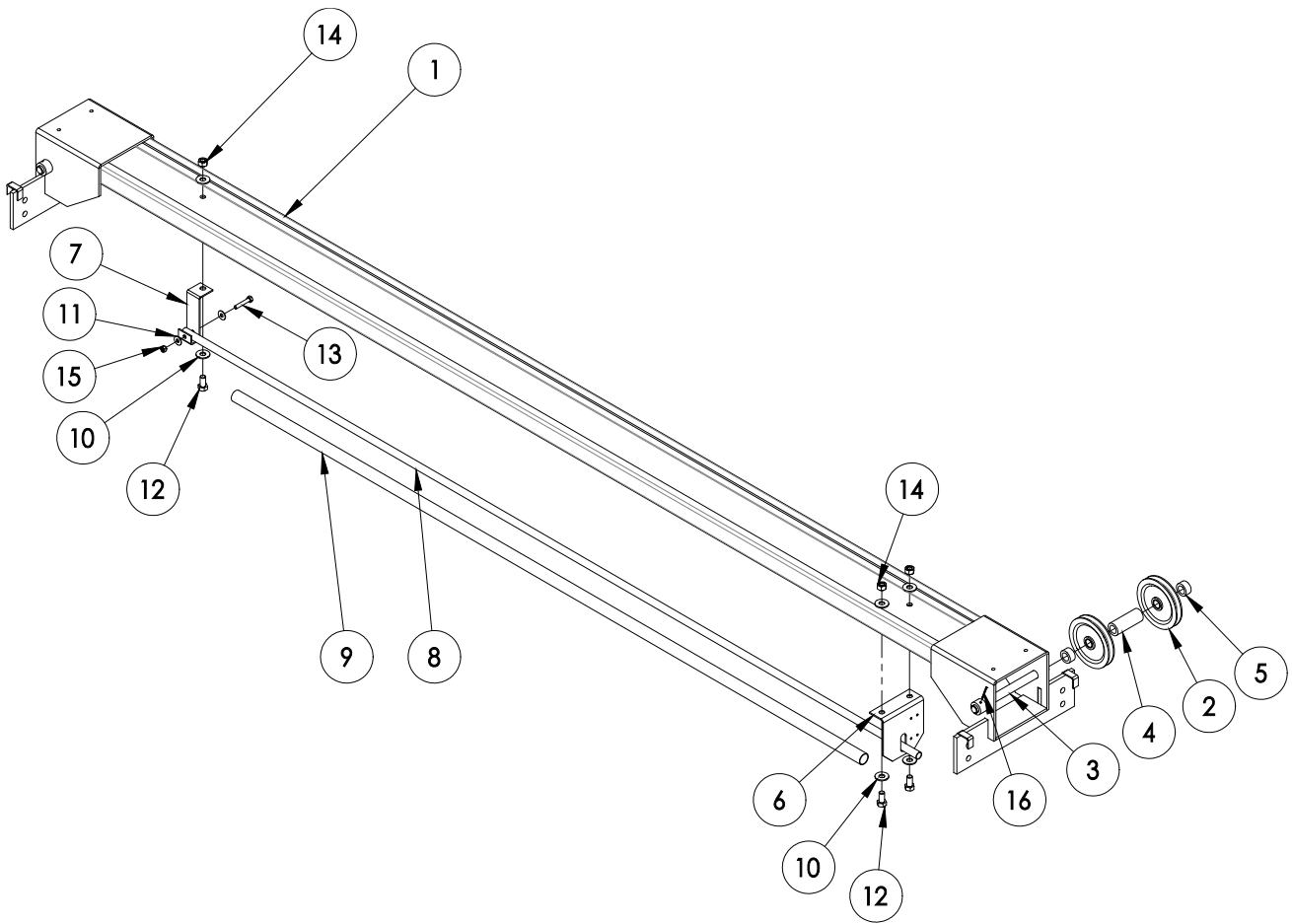

ITEM NO.	PART NUMBER	DESCRIPTION	QTY.
1	22160018	CROSSBEAM	1
2	42160007	PULLEY W/ BUSHING	6
3	12160044	PULLEY SHAFT	2
4	12160048	LONG SPACER	2
5	12160047	SHORT SPACER	4
6	12160118	CROSSBAR SUPPORT	1
7	12160119	CROSSBAR HINGE	1
8	12160125	POLE	1
9	12160130	FOAM	1
10	3C000129	1/2" FLAT WAHER	6
11	3C000143	5/16" FLAT WASHER	2
12	3C000009	1/2" HEX BOLT	3
13	3C000144	5/16"X1.75" BOLT	1
14	3C000025	HEX NUT	3
15	3C000145	5/16" HEX NUT	1
16	32160001	1/8"X1.5 SPRING PIN	1

Diagram #4: TOWER, CARRIAGE AND ARMS ASSEMBLY

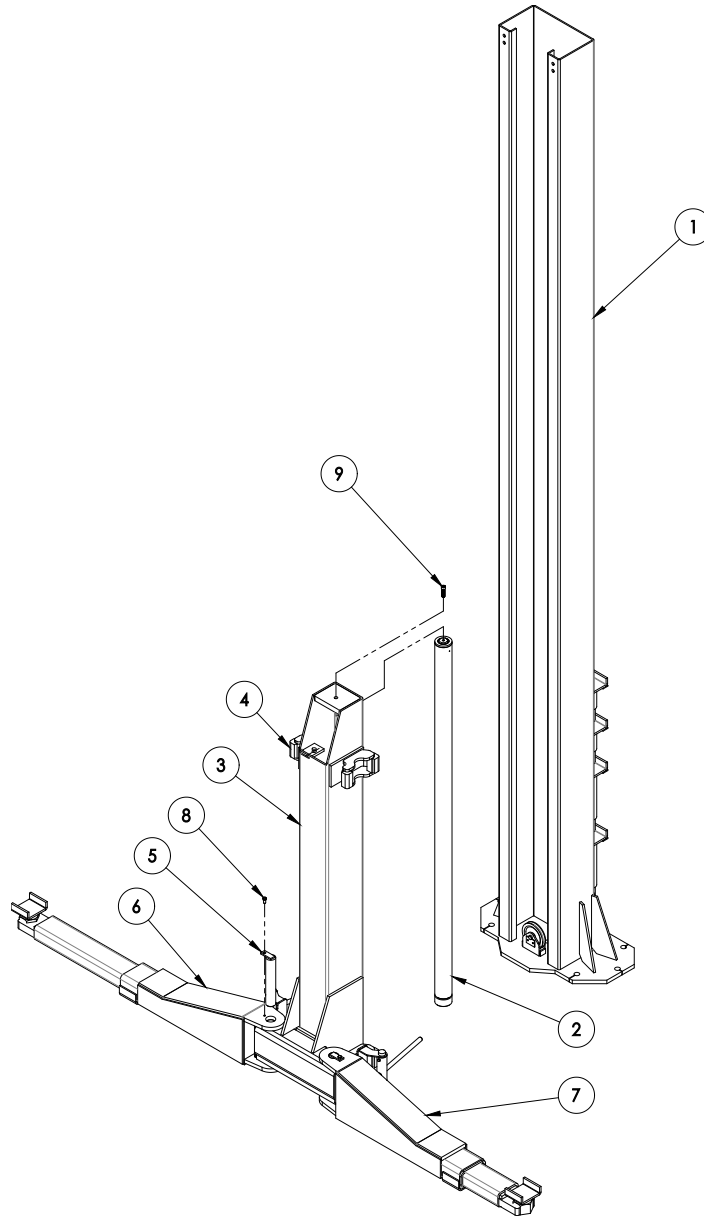

ITEM NO.	PART NUMBER	DESCRIPTION	QTY.
1	42160001	TOWER ASSEMBLY	2
2	42160010	HYRAULIC CYLINDER	2
3	22160001	CARRIAGE WELDMENT	2
4	12160010	SLIDER	16
5	22160004	ARM PIN WELDMENT	4
6	42160003	ARM ASSEMBLY A	2
7	42160014	ARM ASSEMBLY B	2
8	3C000006	3/8"X0.75" HEX BOLT	4
9	3C000070	M12X45 SOCKET BOLT	2

Diagram #5: ARM LOCK ASSEMBLY

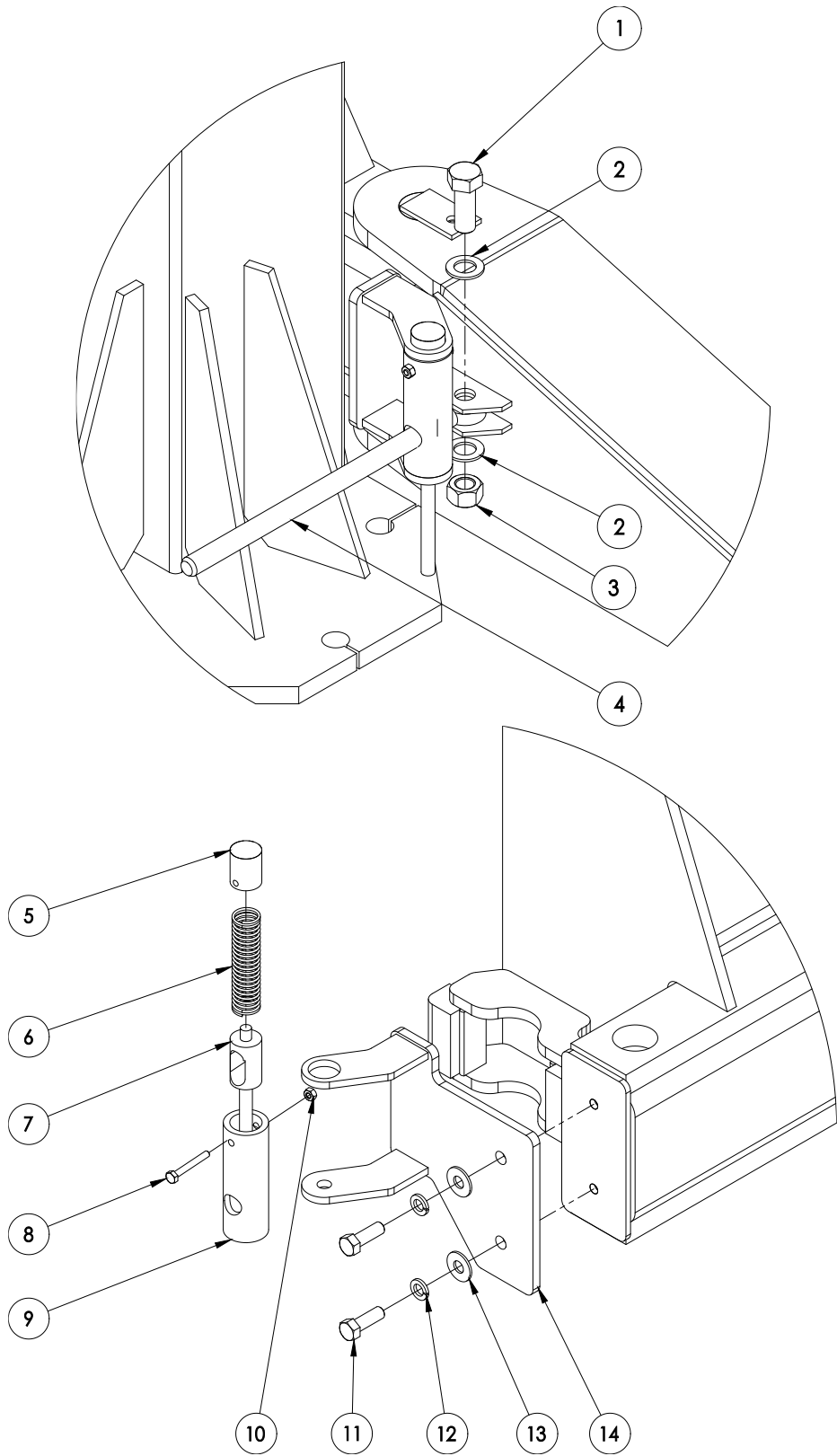

ITEM NO.	PART NUMBER	DESCRIPTION	QTY.
1	3C000148	3/4"X2" HEX BOLT	4
2	3C000146	3/4" NARROW WASHER	8
3	3C000138	3/4" HEX NUT	4
4	22160014	ARM LOCK THREAD	4
5	12160107	ARM LOCK TOP CAP	4
6	12160131	COMPRESSION SPRING	4
7	12160106	ARM LOCK	4
8	3C140066	1/4"X2" HEX BOLT	4
9	12160105	ARM LOCK TUBE	4
10	3C000147	1/4"X2" HEX NUT	4
11	3C000149	1/2"X1.5" HEX BOLT	8
12	3C000008	1/2" LOCK WASHER	8
13	3C000129	1/2" FLAT WASHER	8
14	22160030	ARM LOCK BRACKET (LEFT) (as shown in the explosive view)	2
	22160031	ARM LOCK BRACKET (RIGHT) (the opposite side as in the explosive view)	2

Diagram #6: EQUALIZING CABLES

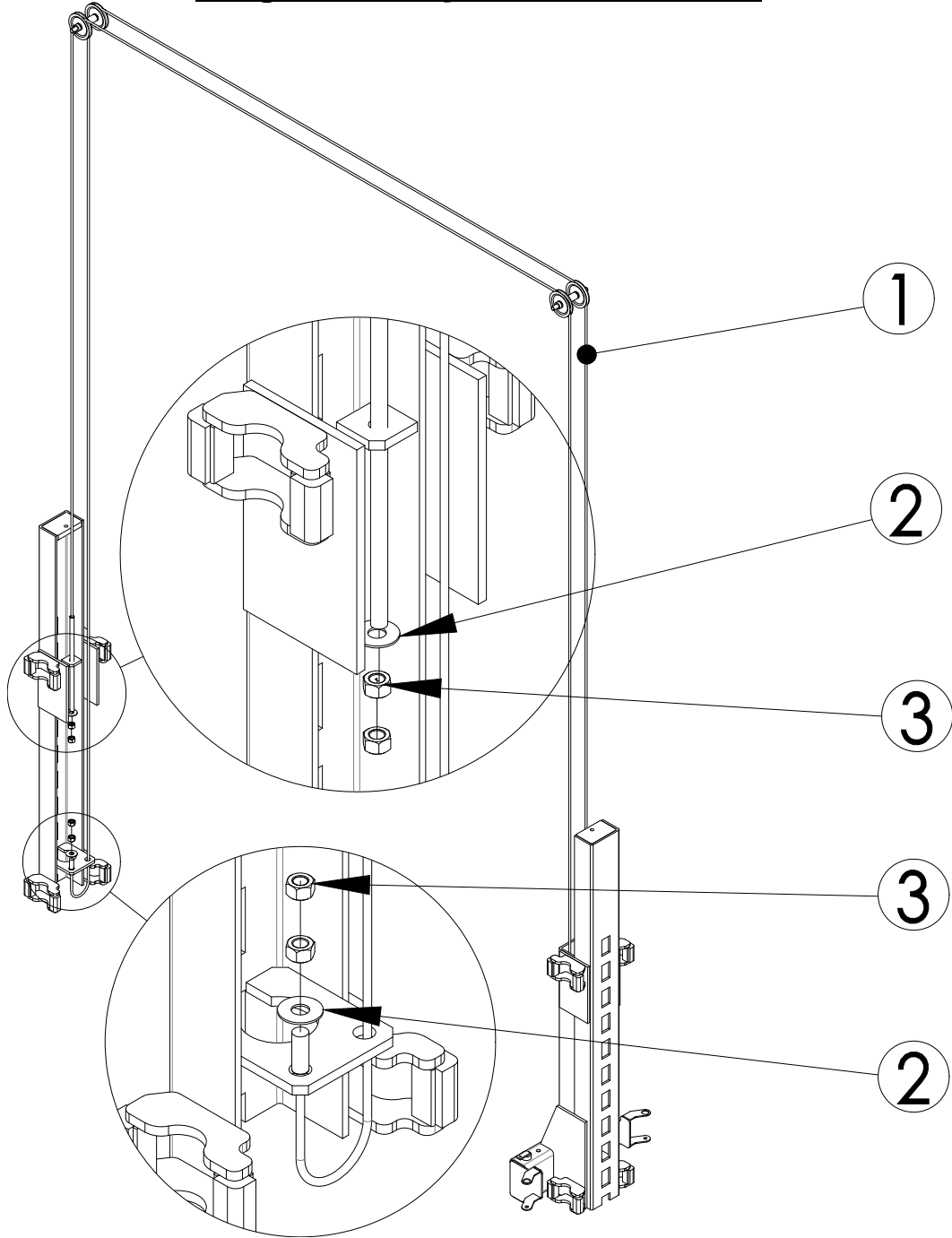

ITEM NO.	PART NUMBER	DESCRIPTION	QTY.
1	32161000	EQUALIZING CABLE (REGULAR: 463")	2
2	3C000137	3/4" WASHER	4
3	3C000138	3/4" HEX NUT	8

Diagram #7: ARM ASSEMBLY

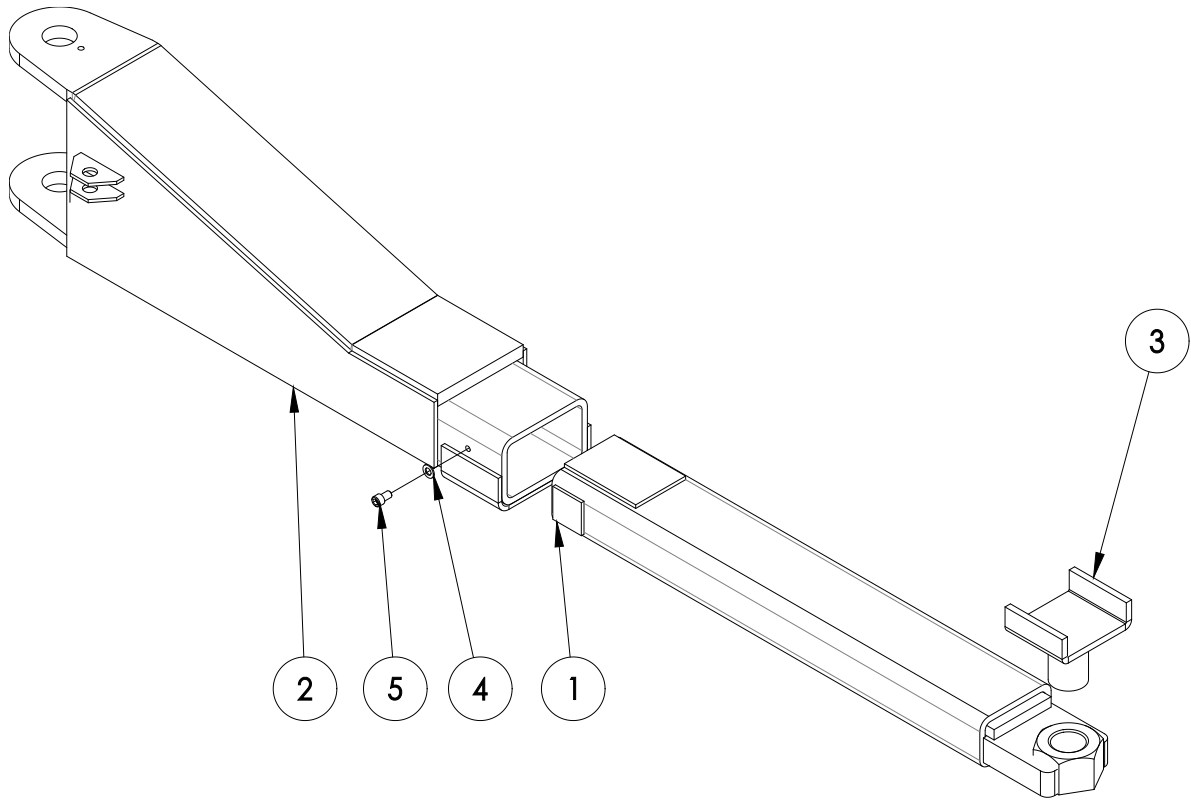

ITEM NO.	PART NUMBER	DESCRIPTION	QTY.
1	22160003	FRONT ARM WELD. (A AND B)	4
2	22160002	REAR ARM WELD. (A AND B)	4
3	22160007	3" ADAPTER	4
4	3C000007	3/8" NARROW WASHER	4
5	3C000153	3/8" SOCKET BOLT	4

Please see diagram #1 for other adapters.

Diagram #8: ANCHOR BOLTS

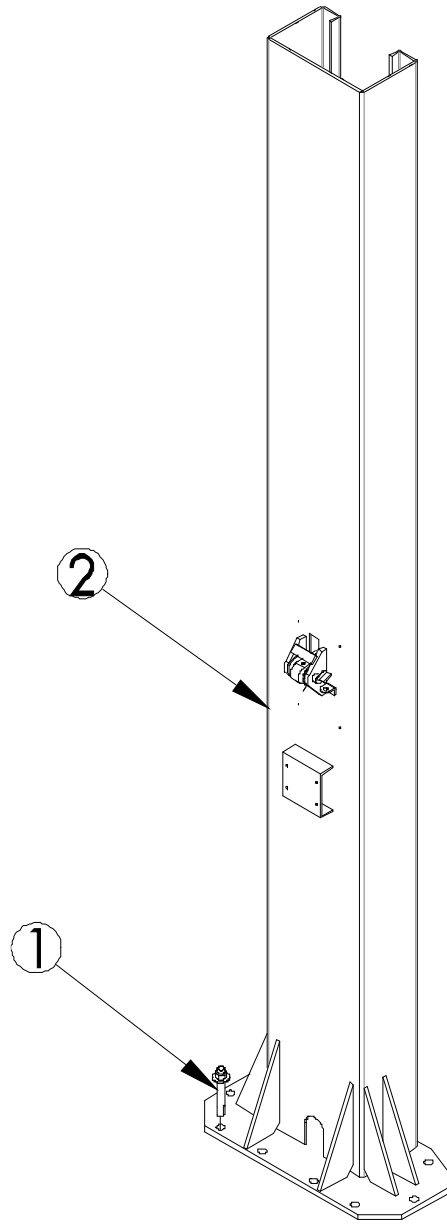

ITEM NO.	PART NUMBER	DESCRIPTION	QTY.
1	12120106	ANCHOR BOLT	16
2	42160001	TOWER	2

Diagram #9: HYDRAULIC SYSTEM

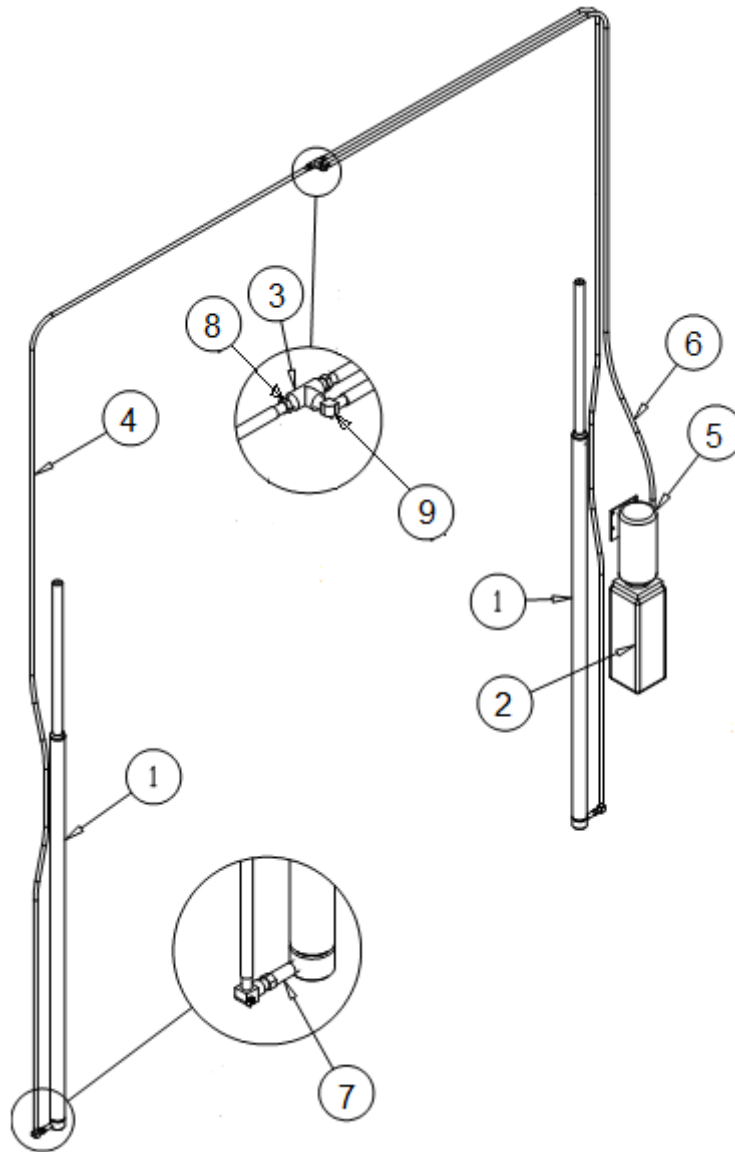

ITEM NO.	PART NUMBER	DESCRIPTION	QTY.
1	42160010	HYDRAULIC CYLINDER	2
2	32160009	POWER PACK	1
3	32160004	3/8 NPT T FITTING	1
4	32160005	HYDRAULIC HOSE (TO CYLINDERS)	2
5	32160003	POWER PACK ELBOW FITTING	1
6	32160011	HYDRAULIC HOSE (TO POWER PACK)	1
7	32160002	3/8 NPT - 3/8 JIC 90 ANGLE	2
8	32160012	STRAIGHT FITTING	2
9	32160013	ELBOW FITTING	1

Diagram #10: AIR LINE

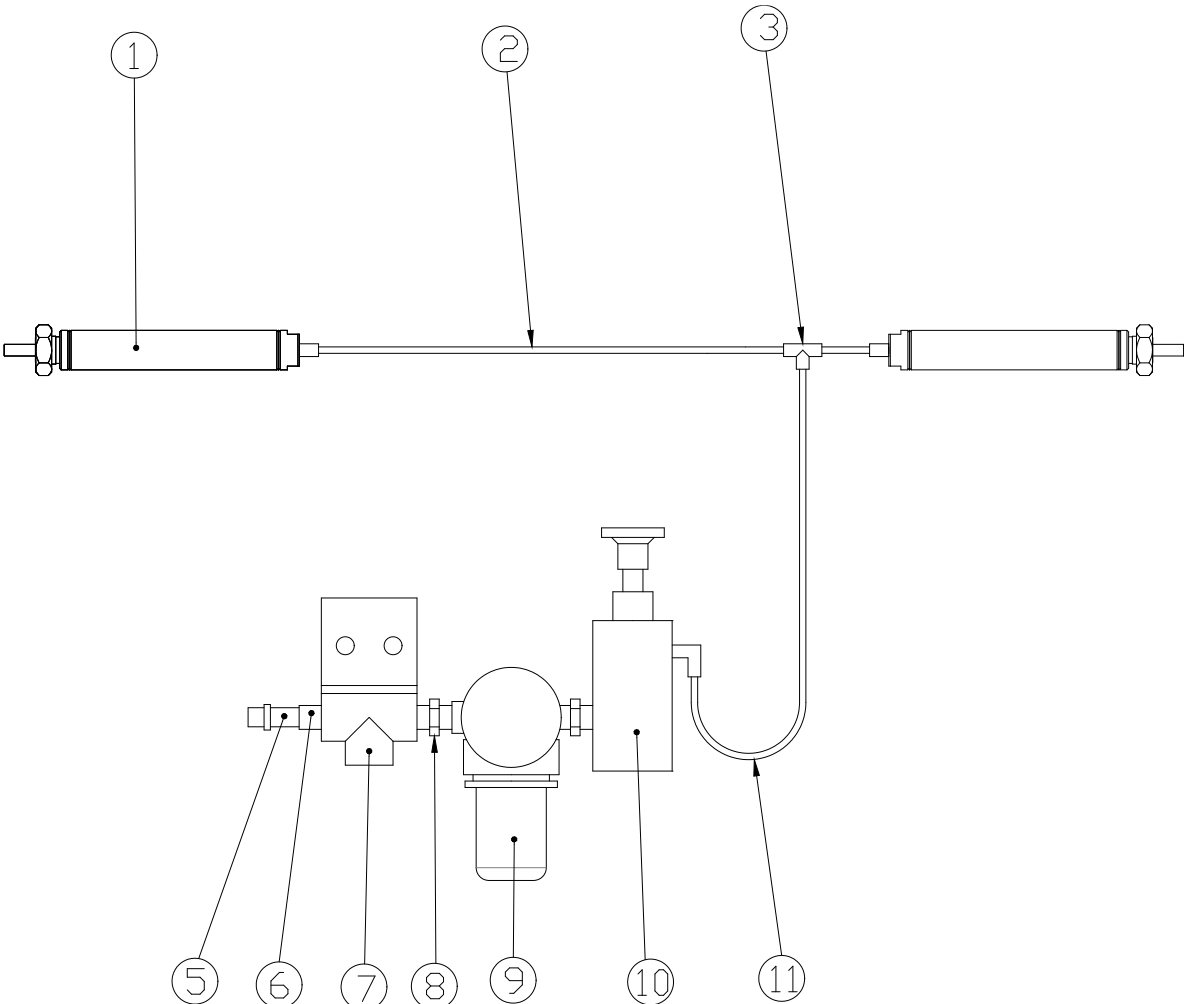

ITEM NO.	PART NUMBER	DESCRIPTION	QTY.
1	32160008	AIR CYLINDER PARKER 0.75 D SR 1.0	2
2	32160010	Polytube 5/32" DIA	1
3	31141063	POLY TEE 5/32" FITTING	1
5	34180017	AIR INTAKE FITTING	1
6	34180015	FITTING	1
7	24180013	PNEUMATIC CONTROLS WELDMENT	1
8	34180015	FITTING	2
9	34180010	AIR REGULATOR	1
10	34180011	AIR VALV	1
11	32160011	Polytube 5/32' DIA	1

Diagram #11: POWER UNIT MOUNTING

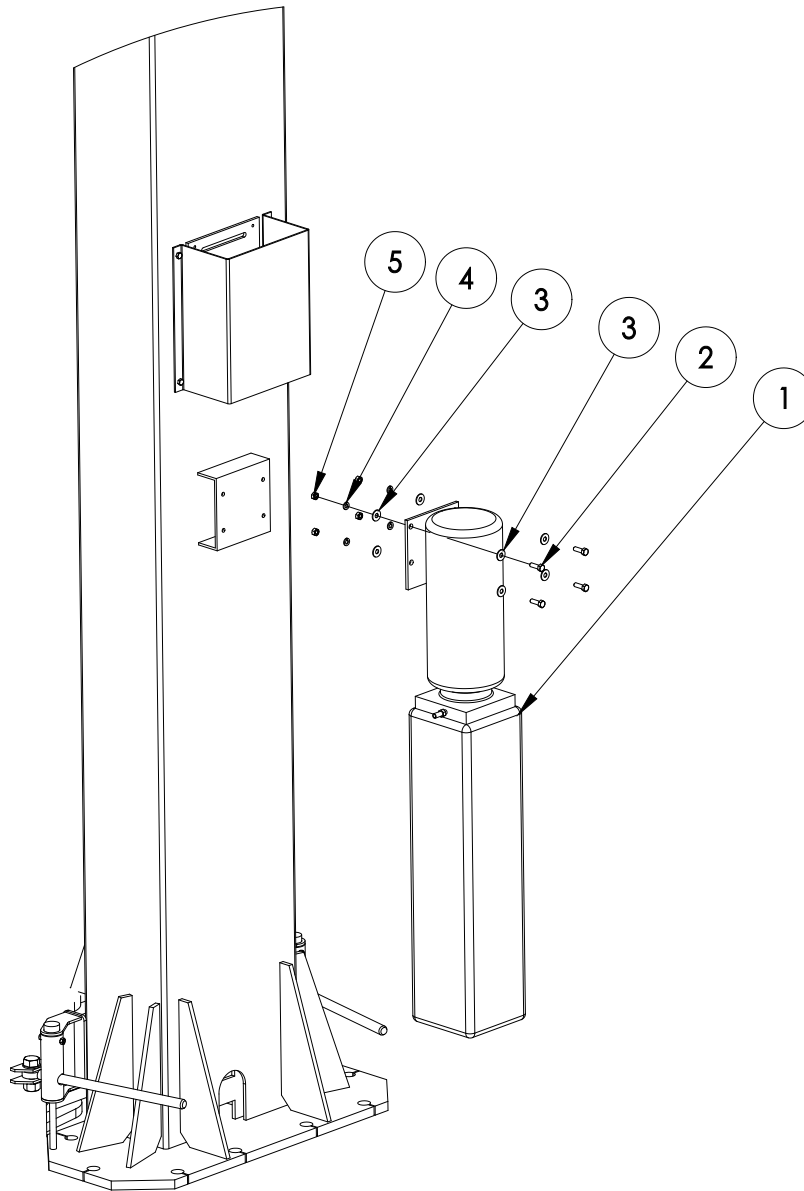

ITEM NO.	PART NUMBER	DESCRIPTION	QTY.
1	32160009	POWER PACK	1
2	3C000131	5/16"X1" HEX BOLT	4
3	3C000143	5/16" FLAT WASHER	8
4	3C000000	5/16" LOCK WASHER	4
5	3C000145	5/16" HEX NUT	4

Diagram #12: LIFTING PAD WITH RUBBER (42160027)

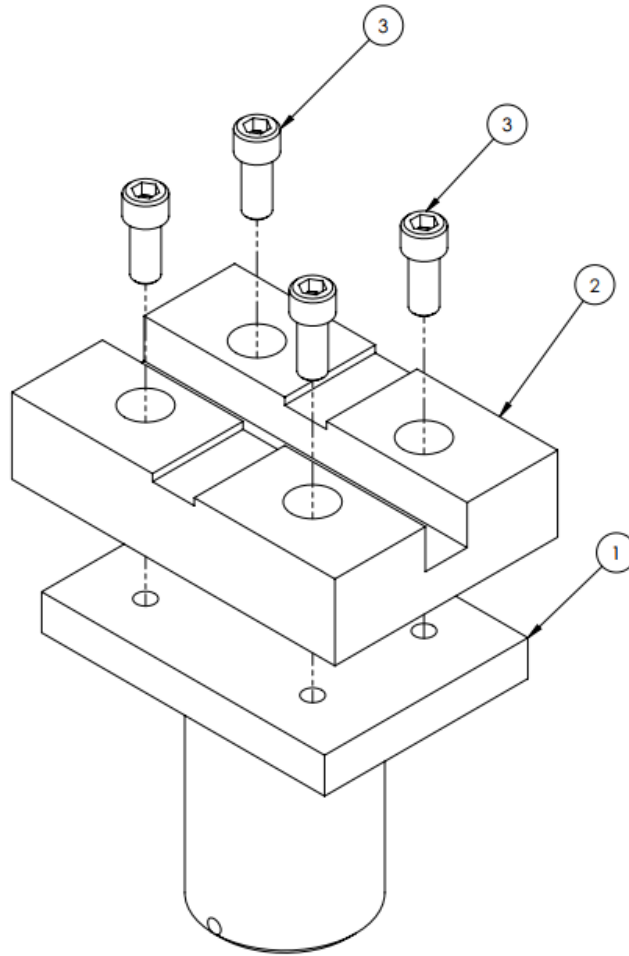

ITEM NO.	PART NUMBER	DESCRIPTION	QTY.
1	22160034	LIFTING PAD WELDMENT	4
2	12100049	RUBBER PAD	4
3	3C100088	5/16-18 SHCS	16

Diagram #13: POWER UNIT WIRING DIAGRAM

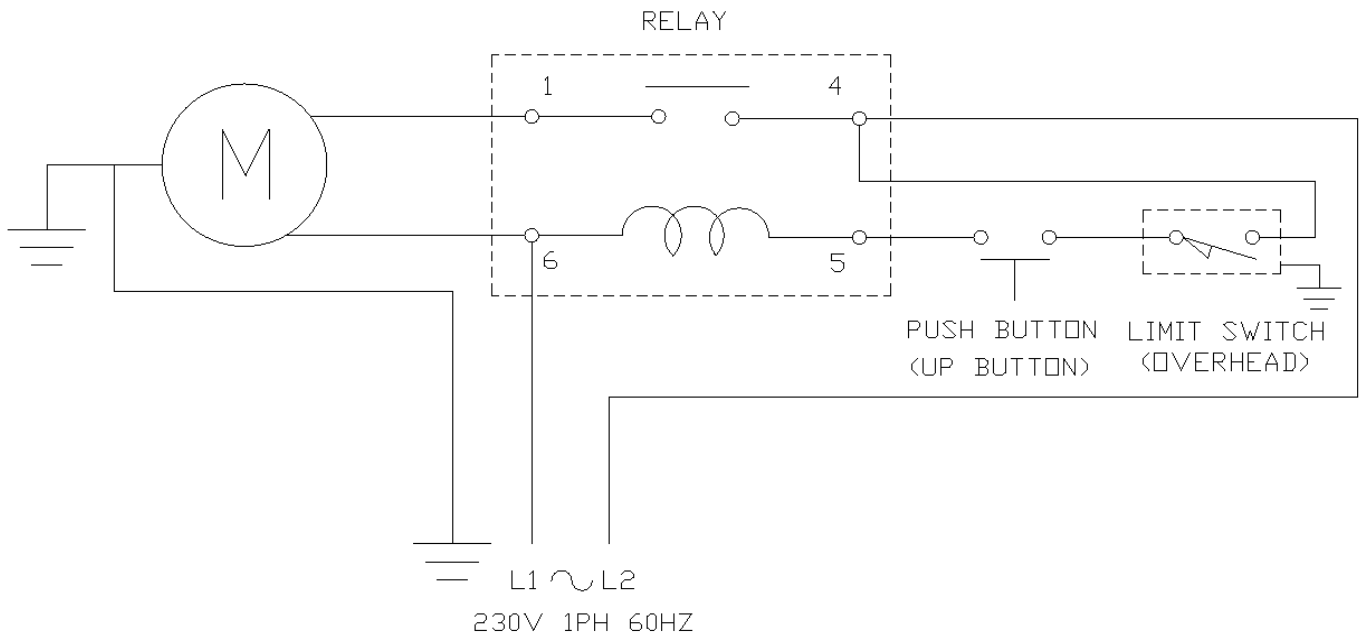
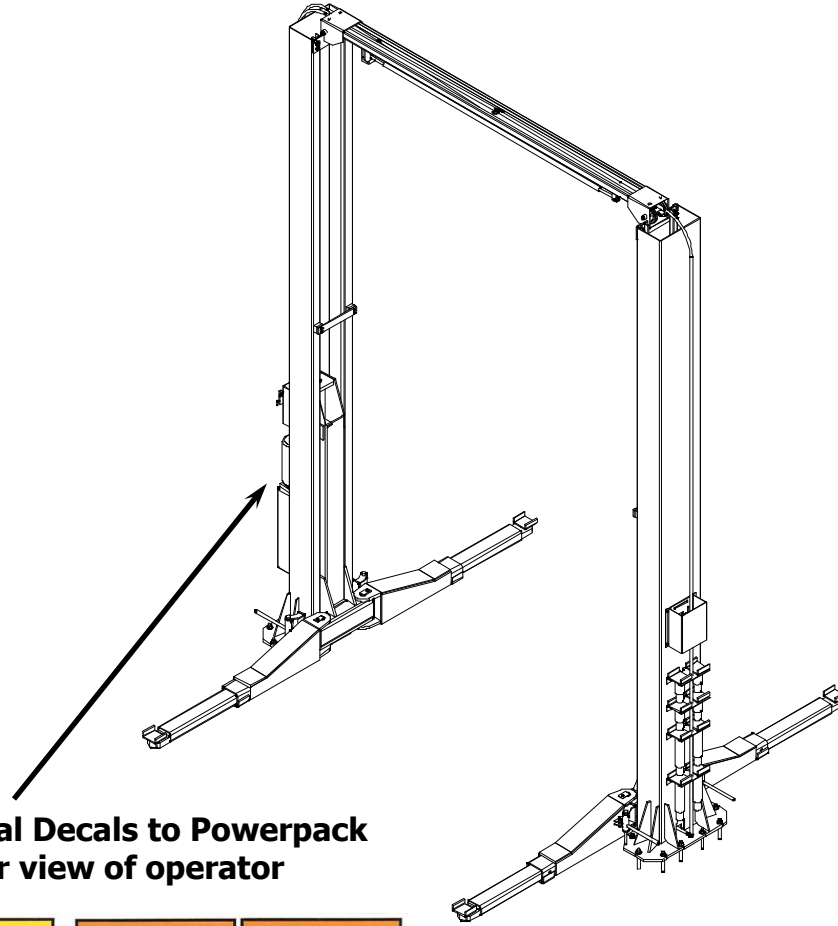

Diagram #14: SAFETY INSTRUCTIONS



Apply Individual Decals to Powerpack Column in clear view of operator

Also Apply to Powerpack Column in clear view of operator

<p>CAUTION</p> <p>Lift to be used by trained operator only.</p>	<p>CAUTION</p> <p>Authorized personnel only in lift area.</p>	<p>WARNING</p> <p>Clear area if vehicle is in danger of falling.</p>	<p>WARNING</p> <p>Position vehicle with center of gravity midway between adapters.</p>
<p>CAUTION</p> <p>Use vehicle manufacturer's lift points.</p>	<p>CAUTION</p> <p>Always use safety stands when removing or installing heavy components.</p>	<p>WARNING</p> <p>Remain clear of lift when raising or lowering vehicle.</p>	<p>WARNING</p> <p>Avoid excessive rocking of vehicle while on lift.</p>
<p>CAUTION</p> <p>Use height extenders when necessary to ensure good contact.</p>	<p>CAUTION</p> <p>Auxiliary adapters may reduce load capacity.</p>	<p>WARNING</p> <p>Do not override self-closing lift controls.</p>	<p>WARNING</p> <p>Keep feet clear of lift while lowering.</p>
<p>The messages and pictographs shown are generic in nature and are meant to generally represent hazards common to all automotive lifts regardless of specific style.</p> <p>Funding for the development and validation of these labels was provided by the Automotive Lift Institute, PO Box 85 Cortland, NY 13045.</p> <p>Replacement label sets may be obtained from the original lift manufacturer and ALI's member companies. They are protected by copyright.</p> <p>www.autolift.org ©1992 by ALL, Inc. ALIWL101s</p>		<p>The messages and pictographs shown are generic in nature and are meant to generally represent hazards common to all automotive lifts regardless of specific style.</p> <p>Funding for the development and validation of these labels was provided by the Automotive Lift Institute, PO Box 85 Cortland, NY 13045.</p> <p>Replacement label sets may be obtained from the original lift manufacturer and ALI's member companies. They are protected by copyright.</p> <p>www.autolift.org ©1992 by ALL, Inc. ALIWL101s</p>	

<p>SAFETY INSTRUCTIONS</p> <p>Read operating and safety manuals before using lift.</p>	<p>SAFETY INSTRUCTIONS</p> <p>Proper maintenance and inspection is necessary for safe operation.</p>
<p>SAFETY INSTRUCTIONS</p> <p>Do not operate a damaged lift.</p>	<p>The messages and pictographs shown are generic in nature and are meant to generally represent hazards common to all automotive lifts regardless of specific style.</p> <p>Funding for the development and validation of these labels was provided by the Automotive Lift Institute, PO Box 85 Cortland, NY 13045.</p> <p>Replacement label sets may be obtained from the original lift manufacturer and ALI's member companies. They are protected by copyright.</p> <p>www.autolift.org ©1992 by ALL, Inc. ALIWL101s</p>